

**UNIVERSIDADE ABERTA**

**INSTITUTO SUPERIOR  
TÉCNICO**



**Framework For E-Business Design Based On Enterprise  
Architecture**

**Magido Juma Mascate**

**Master of Information and Enterprise Systems**

*(master's degree in association)*

**MAY 27<sup>th</sup>, 2020**

**UNIVERSIDADE ABERTA**

**INSTITUTO SUPERIOR  
TÉCNICO**



**Framework For E-Business Design Based On Enterprise  
Architecture**

**Magido Juma Mascate**

**Master of Information and Enterprise Systems**

*(master's degree in association)*

Dissertation supervised by: Professor André Ferreira Ferrão Couto e Vasconcelos

**MAY 27<sup>th</sup>, 2020**

## RESUMO

O ecossistema da economia digital fornece inúmeras pesquisas e modelos conceituais que visam a descrição do padrão da adoção de tecnologia digital de diversas empresas. No entanto, de **acordo com estudos existentes, percebemos que estão faltando modelos de referência de e-business para as pequenas e médias empresas (PME), que apoiem a concepção e adoção de negócios digitais adaptáveis às tecnologias.** Com base na literatura e ferramentas relacionadas existentes, exploramos uma abordagem adaptativa e independente de tecnologia para propor um **modelo de referência de concepção de e-business para PMEs em diversos contextos de negócios, baseada em arquitetura empresarial.** A nossa proposta integra técnicas de gestão comuns e a prática de arquitetura empresarial, com vista a **apoiar os decisores das PME na concepção e implementação de e-business.** A proposta compreende três principais facetas inter-relacionadas, partindo da **1) análise situacional** para a determinação dos fatores motivadores e barreiras do ambiente do negócio; seguida pela **2) avaliação da prontidão da PME** com base na existência de estratégia digital, catálogo de motivadores e propostas de modelos de negócios, e culminando com **3) a faceta de implementação** com base em arquitetura de e-business. Sendo que as duas últimas facetas formam os componentes chave do perfil da PME. Ademais, incorpora-se a quarta faceta de arquitetura de soluções de e-business, seleção e aplicação baseados no ambiente das PMEs. No estudo assumimos uma abordagem prática, propondo e demonstrando a aplicação de ferramentas que apoiam o processo de concepção no contexto real de negócio para as diferentes facetas do nosso modelo.

**Palavras-chave:** arquitetura empresarial, modelo de referência de e-business, estratégia digital, PME, framework de e-business.

## ABSTRACT

Through the digital industry and economy, we find countless researches providing conceptual models aiming to depict digital technology adoption by different businesses. However, according to existing studies, we found that **SMEs lack an e-business reference modelling framework** that supports the design and adoption of digital-enabled business models. Therefore, we **exploit an adaptive and technology-independent** approach to propose an **Enterprise Architecture (EA) based e-business reference modelling framework** for SMEs in diverse business contexts. Our framework comprises mainly of three interrelated building blocks, starting with the 1) situational analysis to determine the motivating factors for change and barriers of the business environment; followed by SMEs profiling. The SMEs profiling embodies the 2) SMEs' readiness depiction based on the existence of digital strategy, digital-value drivers' catalogue, and business models proposals; and culminates with the 3) description of the implementation based on e-business architecture. In addition, a fourth building block is incorporated into the framework for e-Business solutions architecture, selection, and deployment into the current SMEs' business context. In this study, we assume a practical approach, proposing and demonstrating the application of tools that support the conception of an SMEs' e-business in the business context in all the different facets of our framework.

**Keywords:** enterprise architecture, e-business reference model, digital strategy, *SME*, e-business framework.

## **DEDICATION**

To my wife, for her tireless shoulders.

## ACKNOWLEDGMENTS

My special acknowledgment to my supervisor. Also, to my classmates, for their encouragement and mutual support.

# TABLE OF CONTENTS

<b>RESUMO</b> .....	iii
<b>ABSTRACT</b> .....	iv
<b>DEDICATION</b> .....	v
<b>ACKNOWLEDGMENTS</b> .....	vi
<b>LIST OF FIGURES</b> .....	ix
<b>LIST OF TABLES</b> .....	ix
<b>ABBREVIATIONS, SYMBOLS, AND ACRONYMS</b> .....	xi
<b>Chapter 1. INTRODUCTION</b> .....	13
1.1. CONTEXT .....	14
1.2. PROBLEM .....	15
1.3. OBJECTIVE .....	15
1.4. METHODOLOGY .....	16
1.4.1. PROBLEM IDENTIFICATION AND MOTIVATION .....	16
1.4.2. THE OBJECTIVE OF THE SOLUTION .....	17
1.4.3. DESIGN AND DEVELOPMENT .....	17
1.4.4. DEMONSTRATION .....	17
1.4.5. EVALUATION .....	18
1.4.6. COMMUNICATION .....	18
1.5. WORK STRUCTURE .....	18
<b>Chapter 2. BACKGROUND</b> .....	20
2.1. ENTERPRISE ARCHITECTURE AND ARCHITECTURE LANGUAGE .....	21
2.1.1. BUSINESS ARCHITECTURE .....	22
2.1.2. INFORMATION MAPPING AND ARCHITECTURE .....	23
2.1.3. VALUE STREAMS AND CAPABILITIES MAPPING .....	23
2.1.4. THE NOTION OF ARCHITECTURE VIEWS, VIEWPOINTS, AND MODELS .....	26
2.2. REFERENCE MODELS WITHIN THE EA .....	28
2.2.1. DISCUSSION .....	30
2.3. MANAGEMENT FRAMEWORKS .....	30
2.3.1. STEP AND SWOT ANALYSIS PRACTICE .....	30
<b>Chapter 3. RELATED WORK</b> .....	33
3.1. E-BUSINESS ADOPTION PATTERN FRAMEWORK .....	34
3.2. E-BUSINESS MODEL DESIGNING FRAMEWORKS .....	36
3.2.1. DISCUSSION .....	37
<b>Chapter 4. PROPOSAL</b> .....	38
4.1. E-BUSINESS REFERENCE MODELING FRAMEWORK FOR <i>SMEs</i> (J-FRAMEWORK) .....	39

4.2.	CRITICAL ADOPTION'S FACTORS ANALYSIS .....	41
4.2.1.	MODELING A <i>SME</i> 'S <i>CAFs</i> WITH ARCHIMATE.....	42
4.3.	READINESS ANALYSIS FOR A <i>SME</i> 'S E-BUSINESS PROFILING .....	44
4.3.1.	<i>SWOT</i> ANALYSIS FOR <i>SMES</i> ' PROFILING .....	45
4.3.2.	DIGITAL STRATEGIC OPTIONS TRANSLATION ONTO E-BUSINESS MODELS.....	47
4.3.3.	DESCRIBING THE <i>SME</i> 'S READINESS WITH ARCHIMATE.....	48
4.4.	IMPLEMENTATION APPROACH OF A <i>SME</i> 'S E-BUSINESS .....	50
4.4.1.	<i>E</i> -BUSINESS ARCHITECTURE AS A REFERENCE MODEL .....	51
4.4.2.	METHODOLOGY FOR THE ( <i>E</i> -)IMPLEMENTATION PHASE .....	51
4.4.3.	DESCRIBING THE ( <i>E</i> -)IMPLEMENTATION WITH ARCHIMATE.....	53
4.5.	BEYOND THE <i>SME</i> 'S E-BUSINESS ARCHITECTURE.....	54
<b>Chapter 5.</b>	<b>DEMONSTRATION</b> .....	<b>56</b>
5.1.	CASE STUDY OF A TRADITIONAL <i>SME</i> : <i>MERKATOS</i> .....	57
5.1.1.	<i>MERKATOS</i> ' <i>CRITICAL ADOPTION FACTORS</i> DESCRIPTION .....	58
5.1.2.	<i>MERKATOS</i> ' E-READINESS EVALUATION .....	59
5.1.3.	<i>MERKATOS</i> ' E-BUSINESS IMPLEMENTATION DESCRIPTION .....	67
5.1.4.	WRAPPING <i>MERKATOS</i> E-BUSINESS PROFILE REFERENCE MODELS.....	73
<b>Chapter 6.</b>	<b>EVALUATION</b> .....	<b>75</b>
6.1.	COMPARATIVE ANALYSIS OF ∫-FRAMEWORK VS. BASELINE FRAMEWORK.....	76
6.2.	ANALYZING ∫-FRAMEWORK OVER <i>MERKATOS</i> PROFILE REFERENCE MODELS.....	79
6.2.1.	WHAT HAS BECOME POSSIBLE AS BY <i>MERKATOS</i> E-BUSINESS PROFILING.....	79
6.2.2.	SUMMARY OF OUR PROPOSED SOLUTION FRAMEWORK ACHIEVEMENTS.....	80
<b>Chapter 7.</b>	<b>CONCLUSION</b> .....	<b>81</b>
7.1.	CONTRIBUTION .....	82
7.2.	COMMUNICATION .....	83
7.3.	FUTURE WORK .....	83
<b>REFERENCES</b>	.....	<b>84</b>
<b>APPENDIX</b>	.....	<b>87</b>
<b>A: PROMINENT APPLICATIONS OF THE INTERNET IN THE VALUE CHAIN</b>	.....	<b>88</b>

## LIST OF FIGURES

Figure 1.1 Design Science Research Methodology .....	16
Figure 2.1 Value Stream Modeling Relationships .....	24
Figure 2.2 Full ArchiMate Framework .....	26
Figure 2.3 Classification of Enterprise Architecture Viewpoints .....	28
Figure 3.1 Initial Description Model of Integrated E-Business Framework For <i>SMEs</i> .....	35
Figure 4.1 <i>E-business</i> Reference Modeling Framework for <i>SMEs</i> (J-Framework) .....	40
Figure 4.2 Hierarchical Concepts for Environment Assessment .....	43
Figure 4.3 <i>SMEs' CAFs</i> and Stakeholders Motivations Mapping Meta-model .....	44
Figure 4.4. <i>Translation of SWOT</i> Analysis into Strategy View with ArchiMate .....	44
Figure 4.4. <i>Translation of SWOT</i> Analysis into Strategy View with ArchiMate .....	49
Figure 4.5 Business Model Diagram with Archimate Concepts .....	50
Figure 4.6 Translation of Digital Business Model into E-Business Value Stream Map Meta-Model .....	51
Figure 5.1 <i>Merkatos E-Business</i> Motivation Model Description.....	62
Figure 5.2 <i>Merkatos' E-Business</i> Digital Strategy Model.....	66
Figure 5.3 <i>Merkatos' E-business</i> Model Diagram.....	67
Figure 5.4 <i>Merkatos E-Business</i> Value Stream Map Coupled with a bundled Reference Digital ValueAdvertising Online .....	68
Figure 5.4 <i>Merkatos E-Business</i> Value Stream Map Coupled with a bundled Reference Digital Value .....	69
Figure 5.5 Value Stream and Capability MappingAdvertising Online .....	69
Figure 5.5 Value Stream and Capability Mapping.....	70
Figure 5.6. <i>Merkatos' Reference</i> Information MapAdvertising Online .....	70
Figure 5.6. <i>Merkatos' Reference</i> Information Map.....	72

## LIST OF TABLES

Table 2.1 Value Stream Abstract Definition Template .....	24
Table 2.2 Value Stream Decomposition Template .....	25
Table 2.3 Value Stream Stage and Capabilities Mapping Template .....	25
Table 2.4 Information Mapping Template .....	26
Table 2.5 Viewpoint Description Structure .....	28
Table 4.1 Context Digital Elements vs. Influencing Factors Relationship Strengths .....	41
Table 4.2 Mapping of <i>SMEs' CAFs</i> Relationships in ArchiMate Lexicon .....	43
Table 4.3 Stakeholder Viewpoint Description .....	44
Table 4.4 An Example of Mapping Impacted Resources into the <i>CAFs</i> Analysis Matrix .....	45
Table 4.5 An Example of Mapping impacted capabilities into the <i>CAFs</i> Analysis Matrix .....	46
Table 4.6 Template for the Matching of <i>CAFs</i> Digital Elements related <i>SWOT</i> for Digital Strategy .....	46

Table 4.7 Digital-Value Drivers Cataloging and Head-Mapping Matrix Template.....	47
Table 4.8 Template for the Translation of the Digital-Value Drivers into Business Models with Cost vs. Revenue Estimates.....	48
Table 4.9 Strategy Viewpoint Description.....	49
Table 4.10 Layered Viewpoint Description.....	50
Table 4.11 Business Process Cooperation Viewpoint Description.....	53
Table 4.13 Information Structure Viewpoint Description.....	54
Table 4.12 Product Viewpoint Description.....	54
Table 4.14 E-Business Process Vs. E-Business Systems Mapping.....	54
Table 5.1 <i>Merkatos</i> ' <i>CAFs</i> Analysis over Cross-Industry Digital Elements.....	59
Table 5.2 Mapping of <i>Merkatos</i> ' <i>CAFs</i> Impacted Resources;.....	60
Table 5.3 Mapping of <i>Merkatos</i> ' <i>CAFs</i> Impacted Capabilities;.....	60
Table 5.4 Matching of <i>CAFs</i> Digital Elements with its Related <i>SWOTs</i> to Develop Digital Strategy.....	61
Table 5.5 <i>Merkatos</i> ' Industry Digital-Value Drivers' Catalog.....	63
Table 5.6 <i>Merkatos</i> E-Business Model with Estimated Quarterly (Q) Cost vs. Revenue.....	65
Table 5.7 <i>Merkatos</i> ' Value Stream Definition.....	68
Table 5.8 <i>Merkatos</i> ' Value Stream Decomposition.....	68
Table 5.9 <i>Merkatos</i> Value Stream and Capabilities Mapping.....	69
Table 5.10 <i>Merkatos</i> ' Information Reference Catalog.....	70
Table 5.11 <i>Merkatos</i> E-Business Processes vs. E-Business Systems Map.....	73
Table 6.1. Comparative Analysis of the J-Framework vs. Baseline Framework.....	77

## ABBREVIATIONS, SYMBOLS, AND ACRONYMS

### Abbreviations

<i>E-Business</i>	Electronic Business
<i>E-Readiness</i>	Digital Readiness
<i>E-Implementation</i>	Digitally enacted implementation
<i>E-Commerce</i>	Electronic commerce

### Symbols

$\Sigma$	Sum
$\int$	Integral, or Essential, or Fundamental

### Acronyms

<i>SME</i>	Small and Medium Enterprise
<i>ETA</i>	Electronic Transactions Act
<i>EA</i>	Enterprise Architecture
<i>BA</i>	Business Architecture
<i>BPMN</i>	Business Process Model and Notation
<i>BMC</i>	Business Model Canvas
<i>BM</i>	Business Model
<i>BMM</i>	Business Motivation Model
<i>STEP</i>	Political, Economic, Social and Technological
<i>SWOT</i>	Strengths, Weaknesses, Opportunities, and Threats
<i>OS</i>	Opportunities vs. Strengths
<i>OW</i>	Opportunities vs. Weaknesses
<i>TS</i>	Threats vs. Strengths
<i>TW</i>	Threats vs. Weaknesses
<i>DSRM</i>	Design Science Research Methodology
<i>RM</i>	Reference Model
<i>EV</i>	Enterprise View Framework
<i>ICT</i>	Information and communication technology

<i>IT</i>	Information Technology
<i>GDP</i>	Domestic Product per capita
<i>GNI</i>	Gross National Income per capita
<i>IoT</i>	Internet of Things
<i>ISA</i>	Information Systems Architecture
<i>ISP</i>	Internet Service Providers
<i>VSMT</i>	Value Stream Mapping Technique
<i>PME</i>	Pequenas e Médias Empresas
<i>ICEIS</i>	International Conference on Enterprise Information Systems

## **Chapter 1. INTRODUCTION**

## 1.1. CONTEXT

The advent of digital technology, which can be summarized on the Internet and in the wide range of services that are served, has boosted significant changes almost in all social and organizational systems. Concepts such as "digital ecosystem," "digital transformation," "social media," "social networks," "e-commerce," and "digital marketing," among others, are part of the day-to-day of professionals from various sectors and industries. In this era in which the Internet assumes the role of a universal platform concerning the interconnection, communication, and exchange of information between people, objects ("things"), and organizations, it is expected that there are vertiginous and continuous changes in Business ecosystems. In this way, it is pertinent to adapt the business strategies of organizations for their insertion and evolution in the digital business ecosystem.

The digital panorama in Africa is continually changing, and Mozambique is no exception. The mobile phone network covers the entire extent of the national territory, and all carriers offer broadband data service in all urban and suburban areas. Moreover, another significant aspect of digital evolution is the provision of mobile banking services ("Mobile Money/Bank") by the three mobile carriers. Such services empower the business ecosystem and create opportunities for subscribers who, under normal conditions, would not possess a bank account.

According to the indicators of development and adoption of the Internet in Mozambique, about 4 million inhabitants have access to the Internet and use data services [1][2]. This indicator also represents a large part of the market segments of SMEs in diverse industries. However, the benefits resulting from the expansion of the telecommunications network and the existing technological capacity (enablers) are not capitalized by the suppliers of other goods and services to society.

The current situation of *SMEs* indicates the existence of barriers for the adoption of information and communication technologies for the design of e-business and the exploitation of the numerous possibilities of the digital panorama. Although there are limitations (namely the weak online presence of many stores, hotels in the country), e-commerce in Mozambique is a reality; therefore, the state has implemented the Electronic Transactions Act (*ETA*) (Act 03/2017 of January 09).

## 1.2. PROBLEM

The digital ecosystem and economy offer plenty of opportunities for businesses to thrive. Although many corporations and large firms easily engage and thrive in the digital landscape, this is not the case of countless *SMEs* from multiple business contexts. For most of the countries around the globe, *SMEs* are the cornerstone for the economic development of many industries, specifically in developing countries. Unfortunately, researches and literature pinpoint the limited adoption of digital business or digital supported business models by *SMEs*. For instance, as discussed in summary [3], many critical factors are appointed as drivers or hindlers. Hence, as many of the indicated factors are intrinsic to a specific industry or country, notably two problems are unfolded:

- *SMEs*' **lacking e-business reference models to guide the adoption of e-business.**  
Also,
- Literature **lacking e-business reference modeling frameworks.**

Although *SMEs*' *e-business adoption* behavior analysis falls beyond the scope of this work, we agree that every business (enterprise) is a social system [4][5] and behaves differently to others, which is challenging to model its behavior for change. Herein, acknowledging the fact that digital technologies are used for business purposes, these businesses are assumed as having – managed or unmanaged – enterprise architecture (*EA*)[6]. Thus, we are induced to answer the following research question:

- **Which conceptual model should support the development of technology-adaptive e-business reference model based on enterprise architecture of *SMEs*, in diverse industries or business contexts?**

## 1.3. OBJECTIVE

Our objective is to **provide a framework that supports the development of *SMEs* e-business in diverse business contexts and industries by integrating managerial and *EA* practices.** This goal is sustained by:

- Identification of conceptual models regarding *e-business reference modeling and adoption pattern* from former works.
- Analysis of adaptable conceptual models suitable for integrating generic managerial frameworks and *EA* practice components.

- Development of the framework proposal and tools, and demonstrate its application through a case study.

## 1.4. METHODOLOGY

While the goal of this work was to address the limitations on the *SMEs*' e-business design and implementation process, we adopted *Design Science Research Methodology (DSRM)* – described in [7][8] and depicted in Figure 1.1. For instance, we describe how this methodology was implemented in the following subsections:

Figure 1.1 Design Science Research Methodology

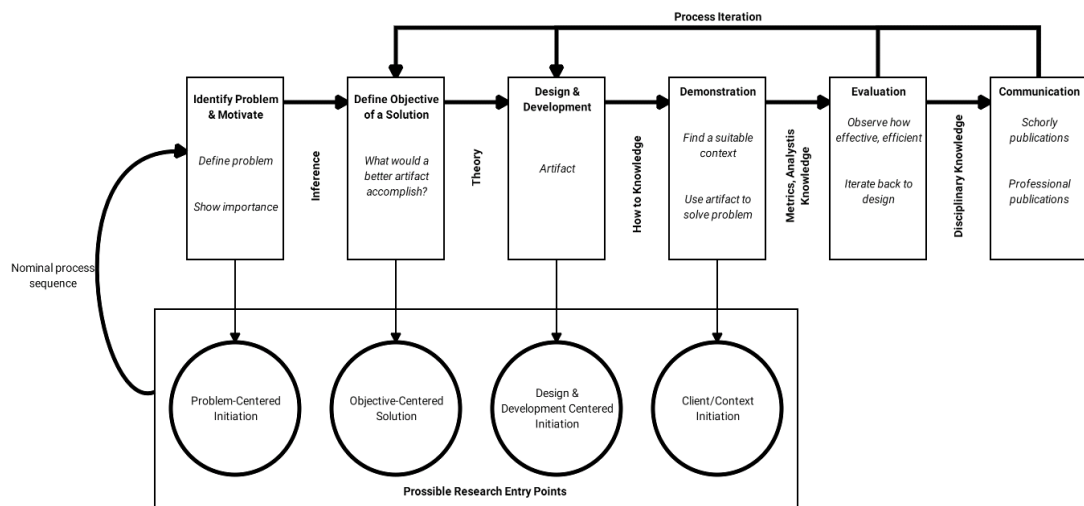

Source: Peffers et al. [7]

### 1.4.1. PROBLEM IDENTIFICATION AND MOTIVATION

In this step, as we described in section 1.2, we positioned our research at the “*problem-centered initiation entry point*”. Based on literature review we found that *SMEs*' lack of e-business reference models and the field of the reference model is underdeveloped. Also, we found that the existing proposals in this field focus on technology-based approaches, while other researches propose an adaptive approach in the e-business design domain, specifically for *SMEs*.

#### 1.4.2. THE OBJECTIVE OF THE SOLUTION

While a limited number of reference work was available at the start of our research, we pursued a design solution based on diverse disciplines and practices. Therefore, **we aim for an integrated e-business reference modeling framework**. The proposed framework should be technology adaptable, and adaptable for **various business contexts of SMEs**. Our proposal should integrate common managerial techniques and enterprise architecture practices, to support **SMEs' decision-makers on e-business design and implementation**. **Also, to support SMEs' context-based e-business systems architecture, and application selection references.**

#### 1.4.3. DESIGN AND DEVELOPMENT

To design and develop the solution within the scope of the objectives defined in subsection 1.3.2, we relied on the process below, which is depicted in our proposal and described in chapter four. We adopted this method in the context of Putra & Hasibuan framework [3], and by extending strategic managerial practices and business architecture disciplines:

- 1) Describe an *SME's* critical adoption factors (*CAFs*) through context assessments.
- 2) Depict one or more digital strategy options based on the context's digital elements.
- 3) Depict a business model based on the digital value drivers of one or more strategic options.
- 4) Depict a baseline e-business architecture through *SMEs'* value streams, capabilities or processes, and information maps.
- 5) Select suitable e-business applications based on the information map references.

#### 1.4.4. DEMONSTRATION

In this work, we present a case study where we demonstrate how the proposed framework should be applied for a real business scenario. In section 5.1, a fictitious traditional marketing agency is presented. In this *SME*, the owner is eager to increase the business profitability to reduce production and publishing costs. From the business context analysis, e-readiness assessment through the implementation phase, we demonstrate how to design a technology-adaptive e-business.

#### 1.4.5. EVALUATION

In this activity, we adopt *Ex Post Strategy* [9] to analyze the objectives of the solution – formerly defined in subsection 1.3.2. We evaluate the proposal through the created reference models, whereby we verify and validate its ability to support the design of *EA*-based e-business in the organizations under study. Also, we perform a comparative analysis on the effectiveness of the integration of *EA* and management constructive blocks into the baseline conceptual model from Putra & Hasibuan [3], respectively, from the perspective of reference modeling independent of specific applications and technologies in use.

#### 1.4.6. COMMUNICATION

Our research has a set of contributions both for practitioners and academia, also for *EA* and managerial-focused audience. This work is available following its approval by a scientific commit, ensuring a continuous refinement of the disciplinary knowledge. Besides, future work is planned to ensure that this work reaches the intended audience through different platforms. For instance, this work is mainly intended for the following audience:

- Architects and developers designing or developing e-business and solutions for *SMEs* e-business.
- Decision-makers seeking a "consistent and common" understanding of e-business development process and digital technology adoption by *SMEs*.
- Users who need a better understanding of the concepts and benefits of *EA* management for the development of *SME's* e-business.

### 1.5. WORK STRUCTURE

This study is organized as follows: in **chapter two**, we present the background, including an overview of enterprise architecture and architecture language, referenced management strategic tools and frameworks, and an overview of reference models. This chapter aims at positioning the study from a multidisciplinary perspective and provide the link with the toolkits for the application and evaluation of our proposal.

In **chapter three**, we present the related work synthesizing the e-business models design and an overview of recent studies of *SMEs'* e-business adoption behavior. These studies represent the knowledge base for our work, and here we aim to exploit its artifacts to construct our

framework. In **chapter four**, we present our proposal for an integrated framework for *SME*'s e-business reference modeling. In **chapter five** we demonstrate the application of the proposed framework in the business context. In **chapter six**, the evaluation of the design artifacts is presented. Finally, the conclusions, including contributions and future work, are shown in **chapter seven**.

## **Chapter 2. BACKGROUND**

## SYNOPSIS

In this chapter, we present the overview on the *EA* with a focus on the business architecture disciplines and its related techniques; also, we refer to management disciplines such as situational analysis practices and the related frameworks. These themes are presented and related to one another and provide the core building blocks for our proposal – an integrated *SMEs* e-business reference modeling framework.

### 2.1. ENTERPRISE ARCHITECTURE AND ARCHITECTURE LANGUAGE

We begin by considering *EA*, the core discipline of our proposed conceptual model, and by providing a brief view of its key concepts. The Open Group [10] defines architecture as “*the structure of components, their inter-relationships, and the principles and guidelines governing their design and evolution over time.*” And, succinctly, an enterprise is a collection of people, departments, business units pursuing a mutual goal. Thus, as quoted in [11], enterprise architecture is “*a coherent whole of principles, methods, and models that are used in the design and realization of an enterprise’s organizational structure, business processes, information systems, and infrastructure.*” In summary, *EA* regards the following concepts: principles, stakeholders, concerns (drivers), models, views, and frameworks [12]. Also, enterprise architecture encompasses mainly four domains: organization, business, information, and technology (*IT* infrastructure) [13]. These domains are coupled together by mean of the information perspective spanning the other three perspectives. The domains are modeled as organization architecture, business architecture, information architecture, and technology architecture. In this work, we focus on the business domain for e-business reference modeling purposes. While the information domain is mentioned in the framework, this serves as a reference point for future e-business solution architecture within a business context or industry.

An *EA* is conceived using an enterprise architecture language. Therefore, in this work, we rely on ArchiMate as a “*reference modeling language*” [14] for e-business modeling. ArchiMate provides a framework for *EA* description and modeling [11] and it is extensively described in [15]. This *EA* language provides iconographic concepts to describe and devise the *EA* domains, motivation, and strategy. Also, its concepts are easily mapped with concepts from management frameworks, like Business Model Canvas (*BMC*) [16]–[18][19], and

Business Motivation Model (*BMM*) embodying techniques like *STEP and SWOT* Analysis. ArchiMate can easily be integrated with a range of other modeling languages, like Business Process Model Notation (*BPMN*) [20].

### 2.1.1. BUSINESS ARCHITECTURE

The business architecture (*BA*) is one of the four domains of *EA*. Business architecture is defined as “*the formalized description of how an organization uses its essential competencies for realizing its strategic intent and objectives*”[21]. Hence, this perspective could be a design “*regarding revenue generation or the channels to be used for delivering products and services to customers*”[13]. A *BA* for a particular field of (commercial) purpose means to be developed in conjunction with the (e-)business model resulting from digital business strategy. The (e-)business architecture perspective that we propose constitutes the core building block of our *SMEs*’ e-business reference modeling framework for diverse business contexts or industries.

From a descriptive perspective, “*business architecture breaks the business model down into the core functional elements that describe how the business works.*” These core elements include “*business capabilities, value streams, organizational structure and information objects required to deliver the desired business result*”[22].

In this work, we use the following concepts: value streams, capabilities, and business processes with an (e-) prefix to emphasize the use of electronic means to create, deliver, and capture value. However, for an in-depth e-business architecture we state that an organization structure model is recommended to be attained to the *SMEs*’ e-business profile. Furthermore, the value streams are linked to its realizing capabilities. Therefore, agreeing with [23], **SMEs can opt-in to adopt e-business in five perspectives of e-business capabilities, namely: 1) communication with customers, 2) order tracking, 3) internal communication, 4) procurement, and 5) communication with partners.**

Moreover, the business architecture process is performed in the business layer of the ArchiMate framework. This way, it becomes easy to align the strategic options and initiative from the sibling above layer – *strategy layer* – and the guiding motivations.

### 2.1.2. INFORMATION MAPPING AND ARCHITECTURE

Although an in-depth focus on Information architecture is out of the scope of this work, we refer to one of its core aspects. “*Information architecture is a logically consistent and coherent set of principles and standards that guide how information is to be managed*”[13]. Information is a key business and organizational resource, and every business aspect is concerned with the production and distribution of information.

Conceptually, “*information (in this context) represents the business information and knowledge required or consumed by the e-business capability*”[24]. Businesses deal with a considerable amount of information in decision-making and transactions; therefore, there’s a need for continuous mapping of information concepts and how they relate to each other. Another critical aspect of information architecture is the relationship of the information with the business activities or processes that produce and/or consume it. This is the most relevant aspect of business interoperability [25] with other organizations through e-business applications.

In order to support the e-business application development and selection, we suggest the elicitation of information concepts for *SME’s* business process. The information concepts are mean to be the most relevant and high-level *information reference* of the *SME’s* for specific industry or business context, and to guide the *SME’s* e-business information systems architecture (*ISA*) in this particular environment or industry.

We suggest that the e-business *ISA* could be handled outside of the (non-technology) *SME’s* boundaries in the industry environment by its solution architecture vendors. Nevertheless, the *SME’s* decision-makers shall be aware of the available e-business solutions and how to implement them, by mean of their e-business profile reference models of this specific industry or country.

### 2.1.3. VALUE STREAMS AND CAPABILITIES MAPPING

As we have earlier stated, our approach for *SME* e-business implementation relies on *SMEs’* value streams, instead of the value chain. “*Value stream is designed to create an end-to-end perspective of [specific] value from the customer’s (or stakeholder’s) perspective, and in doing so, is more closely aligned to realizing an organization’s business model*” [26]. Therefore, to describe a specific business value creation, delivery, and capture sequence of

value-adding key activities, one could apply the *Value Stream Mapping (VSM) Technique*. This is a simple and powerful technique and is supported by ArchiMate. Value stream maps consist of value stages coupled with the enabling capabilities and/or nested capabilities.

Figure 2.1 Value Stream Modeling Relationships

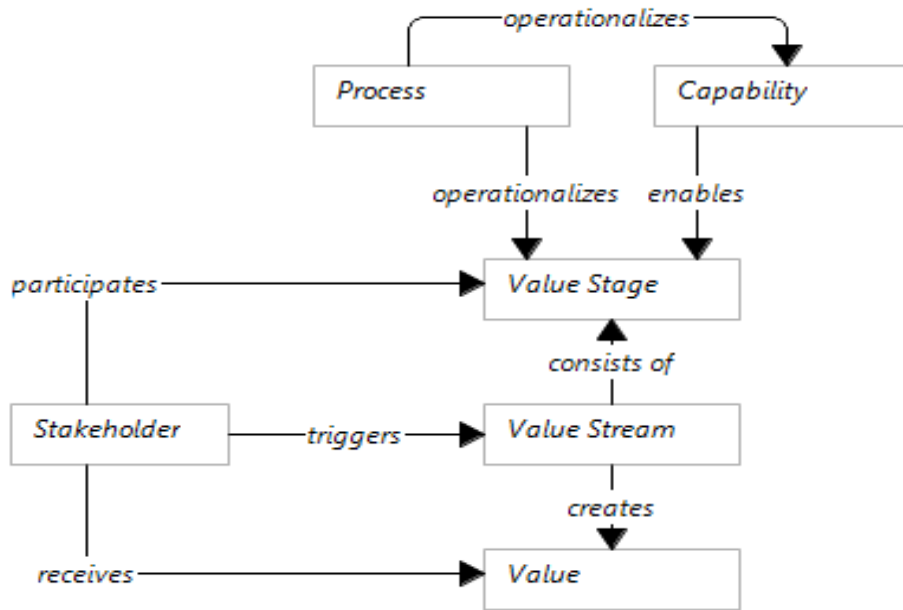

Source: The Open Group [26]

Initially, a value stream is generically defined with four main fields: name, description, stakeholders, and the proposed value.

Table 2.1 Value Stream Abstract Definition Template

	
<b>Name</b>	
<b>Description</b>	
<b>Stakeholders</b>	
<b>Value</b>	

Source: The Open Group[26]

Additionally, the value stream is decomposed in value delivery stages in a tabular structure, with columns for stages' names, stages' descriptions, participating stakeholders, entrances criteria, exits criteria, and value partitions or items; where the rows are the stages of the value stream [26].







Table 2.2 Value Stream Decomposition Template

					
<b>Value stream stage</b>	<b>Description</b>	<b>Participating stakeholders</b>	<b>Entrance criteria</b>	<b>Exit criteria</b>	<b>Value Item</b>

Source: The Open Group[26]

Furthermore, according to the value being produced, the enabling capabilities are mapped into each value stream stage. Hence, a single capability can enable multiple value stream stages. The inverse applies; a single value stream stage can be mapped to one or more business processes and/or capabilities.

Table 2.3 Value Stream Stage and Capabilities Mapping Template

				
				
<b>Capability</b>	<b>Capability</b>	<b>Capability</b>	<b>Capability</b>	<b>Capability</b>
<div style="border: 1px solid black; padding: 2px;">Capability</div>	<div style="border: 1px solid black; padding: 2px;">Capability</div>	<div style="border: 1px solid black; padding: 2px;">Capability</div>	<div style="border: 1px solid black; padding: 2px;">Capability</div>	<div style="border: 1px solid black; padding: 2px;">Capability</div>

Source: The Open Group[26]

For simplicity, one could start the mapping of the high-level information required or consumed by the business capabilities in this phase. For in-depth business architecture, further description step is needed; this regards to the mapping of the business processes operationalizing the capabilities or the value stream stages. In fact, the business process modeling will detail how e-business applications are used to manipulate the business information.

Table 2.4 Information Mapping Template

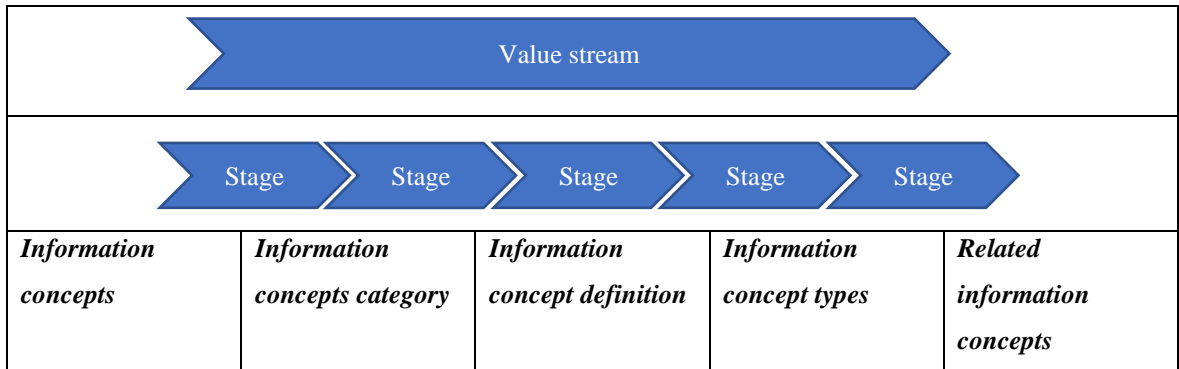

Adapted from: The Open Group[27]

2.1.4. THE NOTION OF ARCHITECTURE VIEWS, VIEWPOINTS, AND MODELS

From the previously mentioned key concepts of the EA, we will define views, models, and additionally viewpoints. A view is a perspective expressing the stakeholder’s concerns (interests) over the four EA domains.

Figure 2.2 Full ArchiMate Framework

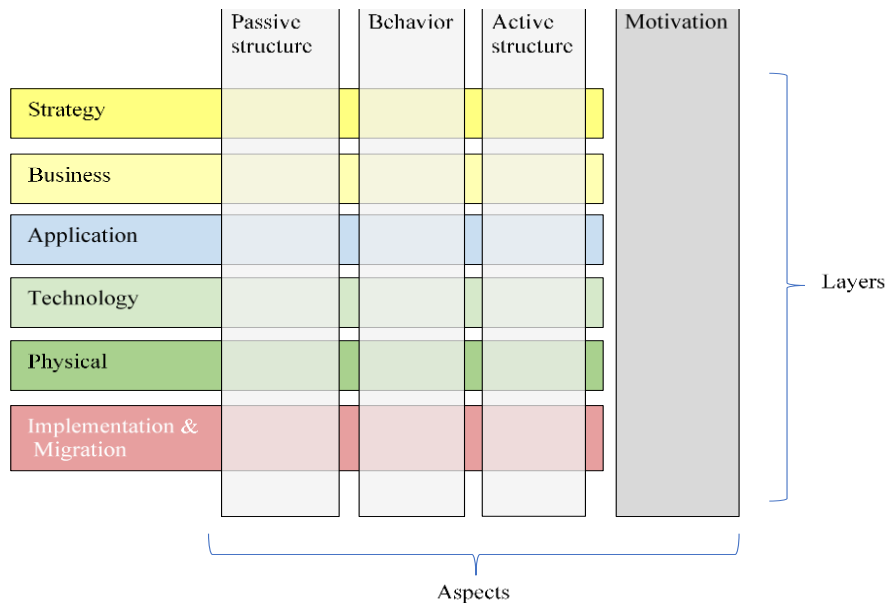

Source: The Open Group [15]

The EA views are expressed by following viewpoints, which establish the convention (patterns, and templates) of how a view will be expressed (devised), interpreted, and used by stakeholders. An architecture view is graphically presented as a model (architecture

model) or set of models forming a logical abstraction of an *EA* domain [28]. Describing an *EA* with the ArchiMate framework becomes straightforward as the essential *EA* viewpoints are already embodied within the ArchiMate specification and modeling tool – *Archi*. These viewpoints are based on different composing layers and aspects of the ArchiMate framework. For instance, one key point to remember is that “*a view is always specific to the architecture for which it is created*” [10].

### **Categories of viewpoints and definition mechanism**

ArchiMate specifies six viewpoint’s categories [15], divided into two dimensions: purpose and content. The viewpoints are categorized accordingly to stakeholders’ concerns; however, one shall follow the same process for their definition. The *purpose* dimension could be classified as:

- **Designing.** This class of viewpoints “*support architects and designers in the design process from initial sketch to detailed design.*”
- **Deciding.** This class of viewpoints “*assists managers in the process of decision-making by offering insight into cross-domain architecture relationships.*”
- **Informing.** This class of viewpoints “*help to inform any stakeholder about the EA, in order to achieve understanding, obtain commitment, and convince adversaries.*”

Also, ArchiMate specifies the following three *content* dimension categories to support the definition of the relevant aspects and/or layers of the architecture view or model for specific stakeholders.

- **Details.** A view in detail level is typically based on one layer or one aspect to describe in detail. Typical stakeholders are business process owners.
- **Coherence.** Architecture view in this level of modeling typically considers multiple layers or aspects to illustrate broad architecture relationships. Typical stakeholders are operational managers.
- **Overview.** This abstraction level considers both multiple layers and aspects. This viewpoint addresses Enterprise architects and decision-makers.

In order to define a viewpoint independently of its category and dimension, ArchiMate specification recommends the following two steps [15]:

1. **Select a subset of relevant concepts** (elements and relationships) from the ArchiMate metamodel based on the information that is needed to address the stakeholder's concerns.
2. **Define a representation** (diagram, matrix) to depict these concepts in a way that is understood by the stakeholders.

ArchiMate specification recommends a structure similar to the following Table to describe a viewpoint.

Figure 2.3 Classification of Enterprise Architecture Viewpoints

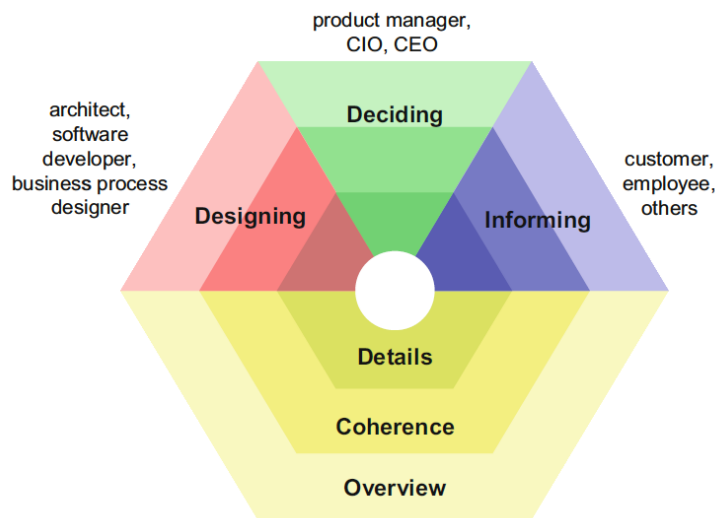

Source: Marc Lankhorst et al. [11]

Table 2.5 Viewpoint Description Structure

<b>Viewpoint name:</b>	
<b>Stakeholders</b>	<i>End-user, business manager, architects, software developers, CxOs (owners)</i>
<b>Concerns</b>	<i>Interest description</i>
<b>Purpose</b>	<i>Design, deciding, or informing or both</i>
<b>Scope</b>	<i>Single layered (Details, coherence) or Multilayered (overview)</i>
<b>Elements</b>	<i>core elements and concepts</i>

## 2.2. REFERENCE MODELS WITHIN THE EA

The term reference model (RM), from academia, lacks consensus [14]. However, we found the following definitions by Bernus referred in [14] and by Fettke & Loos themselves and by The Open Group, in [10], very appropriate for our approach. The Open Group defines reference model as “an abstract framework for understanding significant relationships

among the entities of [an] environment, and for the development of consistent [...] or specifications supporting that environment”. The former authors states that reference models “capture characteristics common to many enterprises within or across one or more [industry] sectors, [...] and may be used as a blueprint for [...] system development.”

Despite the divergences of the definitions, not all reference models are merely about the development of information systems. Hence, by considering an enterprise as a type of system (a social system), both definitions showcase our study and proposal. For instance, we:

- Depict common characteristics of *SMEs*´ in a business context or industry, to use these characteristics in the conception of similar e-business models independently of technologies or adapt to an *SME*´s specificity. Also,
- We depict the information concepts as blueprint enabling the development of e-business information systems.

Moreover, Fettke & Loos, in [14], state that reference models offer the following practical benefits to a business:

- Be reused and adapted to derive a particular enterprise’s model [such as an *SME*´s e-business architecture].
- Be used as a benchmark to analyze and identify gaps of an enterprise-specific model and its validation.

In summary, within the *EA* domains, reference models are created, managed, and used in practice to guide the development of better enterprise models. Agreeing with [29], reference models are constructed in *EA* practice by either adapting other models or by abstracting some into a new one. In either case, to evaluate a *Reference Model*, one of the key aspects is quoted in [29]:

- A reference model is validated by using to create models that are assessed in terms of quality and usefulness of the *Reference Model* and the derived models.

However, designing the evaluation of reference models is described as a difficult process, and there is not any evaluation framework for every scenario. So, for this purpose and peculiarity of work, we found the deployment perspective in [14] as the appropriate evaluation approach. This approach is focused on the *understandability, appropriateness, and attitude* applied to information systems reference models evaluation. We are adopting these criteria to validate our proposed framework’s reference models.

### 2.2.1. DISCUSSION

*Reference modeling* discipline is an underdeveloped field of study, and presents a few kinds of research, although it is well known in the context of information systems developments [14]. Lack of research related *RM evaluation* is a drawback for this study. However, the existing knowledge base provides a green light for our study approach – within the business perspective – and provide critical foundations for the development of this work. Despite lacking consensus, the concept of *RM* is not far from architecture viewpoints, defined in the subsection 2.1.4 above. Also, Reference Models are generic and are reusable artifacts that are stored in libraries.

### 2.3. MANAGEMENT FRAMEWORKS

In a business context, we quickly find common analytical and modeling frameworks being used by management personnel in decision making. From this plethora of tools, the *STEP* (social, technological, economic, and political) and *SWOT* (threats, opportunities, weaknesses, and strengths) Analysis are commonly used by *SMEs*. Moreover, the strategic analysis processes lead to business model innovation, for instance, recently, the very intuitive and straightforward used framework for business model's design is *BMC* [19]. Though, as we stated earlier in this work, in order to keep our proposal close to commonly managerial practices, we approach these frameworks. Thus, in the following section, we present related reference works.

#### 2.3.1. STEP AND SWOT ANALYSIS PRACTICE

The *STEP* are relevant factors that every business considers (or needs to) regardless of its size and goals [30]. This macro-environment assessment approach is most of the time coupled with other popular *SME*'s micro-environment analysis approaches, like *SWOT*. In this work, we adopt both the *STEP* and *SWOT* analysis frameworks to support the understanding of the *SME*'s context factors both external and internal. Also, for an enhanced decision-makers understanding of the drivers and deters of *SME*'s e-business adoption, and to come up with digital strategic options. The following steps by [30] guide the coupling of these frameworks:

- 1) Identify environment factors

- 2) Analyze possible effects on the *SME*
- 3) Categorize factors into opportunities and threats
- 4) Prioritize factors accordingly with *SME's* Goals
- 5) Develop strategic actions or course of action

The *STEP* analysis for *SME's* e-business design is recommended to be held at *national or subnational strata* [30]; while the *SWOT* analysis is to relate the outside digital-related opportunities and threats with the inside digital-related weakness and strengths of the *SME*. From the opted-in course of action is designed any e-business model of an *SME's* for a specific business context or industry. Therefore, agreeing with [30], national policy factors that may have a significant impact on digital strategy like *fiscal policy, Information and communication technology (ICT) adoption incentives, ICT regulations and government supporting of a specific industry* could be taken in consideration. The economic factors are those that most affect the profitability of a business or industry, and the main indicators are *Domestic Product (GDP) per capita, Gross National Income (GNI) per capita and actual country inflation* affecting the ability of providing *products and services* either for final consumers (e.g., people) or clients (e.g., businesses or organization). Thus, in the context of e-business, some of the factors to consider are the local economy, channels of distributions, and access to the market.

Social factors as by [30] have an impact on the way people work, live, and how they form a relationship with others or define their preferences/expectations on products or services. These factors are mostly related to socio-cultural and education aspects of a social system like *demographic characteristics, ICT literacy ratio, the effect of advertising and public relations, influencers and lifestyle changes*. Finally, the technological factors affect the way business moves out of the boundaries of the present limitation in the digital era. These factors are related to information (e.g., set of *data*) and mostly to the technology domain of the enterprise architecture (e.g., *cloud, Internet of Things (IoT), etc.*). Moreover, they should be addressed in the perspective of *innovations in the pricing of innovations in the distribution channels, innovation in the business process support, etc.*

By considering the idiosyncrasy of *SMEs* and business contexts, we claim that these approaches can guide the designing of industry or country-specific e-business models and its technology-independent implementation patterns. Nevertheless, the technology-related aspects of the e-business needs to be continually considered in the evaluation of the critical

adoption factors process within the framework, in terms of availability and usage of technology, for instance for data collection, processing, storage, and communication, in broader ways.

## **Chapter 3. RELATED WORK**

## SYNOPSIS

This chapter presents a discussion over the main referenced works, researches, literature, techniques related to e-business frameworks, that support our proposal. There are two streams of studies: one from the practitioners' perspective related to the design of digital supported business, and another from the academia perspective related to the framing of digital business adoption's patterns of *SMEs*. Moreover, we present the identified conceptual models serving as the basis for our proposal.

### 3.1. E-BUSINESS ADOPTION PATTERN FRAMEWORK

In our days, it is unimaginable a business that doesn't use ICT resources regardless of its size. Although the concepts of e-business stand for the use of electronic technologies in support of business activities, researchers argue that its adoption approach by *SMEs* and businesses, in general, must be adaptive and technology-independent [3][31]. “*The use of a technology-independent model provides the freedom to choose the implementation technology on the basis of other criteria, and thus minimize the cost-benefit ratio and maximize the return on investment*” [14]. **Thus, we develop our e-business reference modeling framework by following this approach.** In fact, there are many e-business technologies and technology-based frameworks. However, as discussed in existing studies, they lack guidance – to support *SMEs'* decision-makers – on the e-business adoption process in diverse *SMEs'* industry or country's context. Thus, e-business models are not designed independently of the technologies [31].

From this existing research, we identified the baseline conceptual model for our study - *Initial descriptive model of integrated e-business for SMEs framework* – as by [3] (cf. Figure 3.1). This work suggests three facets for *SME's* e-business adoption:

- 1) *for* the **critical adoption factors** influencing the *SME* e-business readiness,
- 2) *for* the **readiness** encompassing *SME's* profiles in a specific industry or country and,
- 3) *for* the **implementation** facet where *SME's* decision-makers decide to adopt an e-business.

By proposing this framework, the authors argue that the existing frameworks “insufficiently provide a practical tool for *SMEs* to implement e-business.” In addition, they claim the need for an established set of *CAFs* of e-business for *SMEs* serving as a source of indicators in

signaling the readiness of *SMEs* to adopt e-business. So, due to the idiosyncrasy of *SMEs* in nature and the business environment, we argue that establishing a set of generic *CAFs* could be misleading. Instead, we suggest establishing purposeful tools and methodology to guide an *SME* on assessing its context *CAFs* based on digital key elements of any moment in time of an *SME* lifecycle.

Also, summarizing former research, the authors contextualize the *SMEs'* readiness as based on strategic vision, enterprise financial resources, management's IT skills, and employee's IT skill and attitude. Moreover, they argue that is a need to “relate the critical adoption factors to *SMEs* readiness profiles” and suggest a readiness evaluation as *SMEs'* profiling. From this standpoint, we agree on *SMEs'* profiles as relevant reference components for e-business adoption patterns evaluation. However, we state that an *SME's* Profile must span the readiness and implementation facets, comprising all necessary e-business adoption references. Also, we state that **an *SME's* readiness profile needs to address digital context**

Figure 3.1 Initial Description Model of Integrated E-Business Framework For *SMEs*

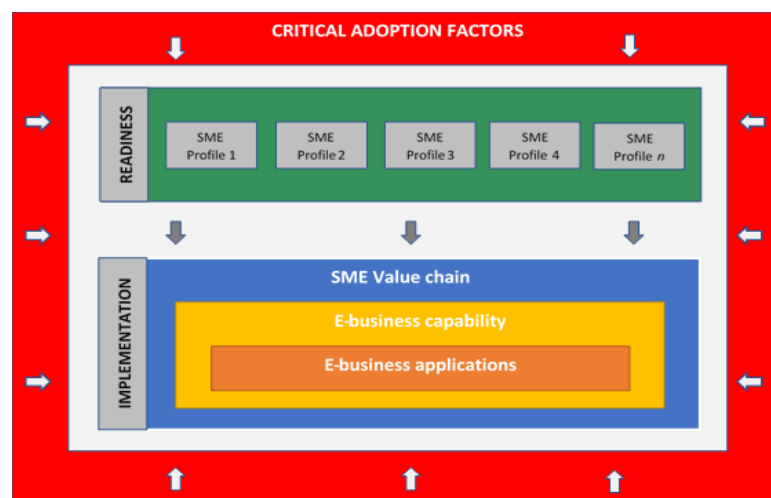

Source: Putra & Hasibuan [3]

**aspects such as digital strategy and digital business model.** By following our approaches, *SMEs'* e-business will be well structured for future evaluation of the e-business adoption maturity.

Moreover, this framework proposes an implementation perspective based on *SME's* value chain. We agree that this perspective is appropriate for the overall e-business adoption maturity evaluation. The value chain “provides a macro-level view of how a business

produces an economic value (i.e., money)”[26]; and *SME's* value chain could encompass too many processes (*cf.* Appendix A), which could limit a one-time e-business adoption approach. So, **we state that adopting e-business through the value chain could be a challenging approach for *SME*, specifically for those in developing countries.** Instead, **we suggest a more granular adoption perspective through value-streams, and specific activities in the value chain;** where “a complete set of value streams denote the organization's primary set of business activities” [26]. To adopt this approach, we propose a strict modification of this baseline framework by adding necessary building blocks to complement its functionality.

In addition, an important point to highlight from the base research is the authors' intent to use the *design science* paradigm to develop artifacts as the outcome of the analysis in the context of **people, organizations, and technology**. This approach aligns with the approach of Enterprise View (*EV*) Framework discussed in the following section 3.2.

### 3.2. E-BUSINESS MODEL DESIGNING FRAMEWORKS

Following the context's analysis, the strategic options are spotted, and this could lead to business innovation process through business model designing. A business model is an intermediary element between strategy and tactics [32]. The “*business models [...] provide a basis for establishing a common understanding of how to describe and manipulate the business in pursuit of new strategic alternatives*” [22]. For e-business modeling purposes, we identified the *BMC* – a well-known framework in the context of management, among others within the *EA* discipline.

The *BMC framework* describes an e-business in intuitive and straightforward ways, and some researchers have proposed some extension of it to facilitate the digital business or digital-enabled business model design. One extension that we found fitting our purpose is the *EV Framework* [33] – based on *BMC*. This is a powerful framework that supports the development of e-business models through core digital concepts as 1) digital connected people, 2) digitally-connected businesses (organizations), 3) digitally connected business assets, 4) business information (set of data) as a digital resource, and 5) digital services' infrastructures (directly or indirectly owned IT infrastructures).

**This approach implicitly claims that *SMEs* pursuing different business goals, within an industry or country can share the same digital key elements.** Therefore, these *SMEs* need

to articulate their business models in one or more of the *BMC* components to pursue a specific strategy or *course of action* and realize business drivers and goals. Moreover, with this approach, one or more digital-value drivers are explicitly mapped with each digital key element and business model component. The *EV Framework* is supported by a questionnaire-based methodology, also presented in [33], and this is useful for the elicitation of current or future digital value drivers out of the business environment.

Additionally, within the *EA* discipline, we found research and practitioners proposing mechanisms that support the translation of *BMC* into architecture models, with ArchiMate language[15][17].

### 3.2.1. DISCUSSION

Cigaina & Riss [33] work has valuable insights about the cross-industries digital elements, and the depiction of digital strategies through its related digital-value drivers. Even though, they scope their research in a digital business model design context only. So, we posit that adopting this some aspect of *EV* framework, which is based on *BMC*, is helpful for the modeling process of the *SMEs e-business models* with ArchiMate. Also, by integrating business models in our proposal aligns with some BA practitioners standpoints [22]. It's recommended that an (*e-*)business architecture is based on business models and, in turn, business models are aligned with business strategy.

## **Chapter 4. PROPOSAL**

## SYNOPSIS

In this chapter, we present our *SME's* e-business reference modeling framework proposal. This framework is made up of three facets from e-business conceptualization to implementation. Also, it incorporates an extra building block addressing the e-business solution architecture to be managed outside the *SME's* boundaries by e-business solution providers. We present a similar approach as the research basis by Putra & Hasibuan [3], to emphasize the devising of *SME's* e-business adoption model. In the following sections, we demonstrate how this analysis is accomplished by mean of different tools and techniques are combined together to support our proposed framework (J-Framework) (*cf.* Figure 4.1).

### 4.1. E-BUSINESS REFERENCE MODELING FRAMEWORK FOR *SMEs* (J-FRAMEWORK)

We adopt the enterprise architecture (*EA*) based approach to propose an integrated e-business reference modeling framework (*cf.* Figure 4.1). Basically, this framework comprises three facets [3]. **Firstly**, from the baseline framework *CAF facet* (*cf.* Figure 3.1), we incorporated four building blocks for the situational analysis relying on STEP analysis, over the digital elements: people, organization, information, and technology, with more details in section 4.2.

**Second**, from the baseline framework (*cf.* Figure 3.1) *Readiness facet*, we spanned the *SMEs* profile component covering both the (*e-*)readiness evaluation facet and (*e-*)implementation facet. And for *Readiness facet* per se, we introduced digital strategy, digital business model, and digital value drivers as key components for (*e-*)readiness *assessment*. In addition, to ensure the *SME's* readiness is related to the *CAFs*, we incorporated instances (people, business, data, etc.) of environment's digital elements (people, organizations, information, and technology) into the digital strategy building block – were *SWOT* analysis is performed, with more details in section 4.3.

**Third**, from the baseline framework (*cf.* Figure 3.1) *Implementation facet*, we introduced the (*e-*)business Architecture building block, and we substitute the *SME* value chain with e-business value stream and e-business application by e-business process. Additionally, we include the Information map building component. (*e-*)business architecture takes business

model contents as reference inputs and provides two reference artifacts 1) e-business information map and 2) digital value. This facet is described in the following section 4.4.

Figure 4.1 E-business Reference Modeling Framework for SMEs (J-Framework)

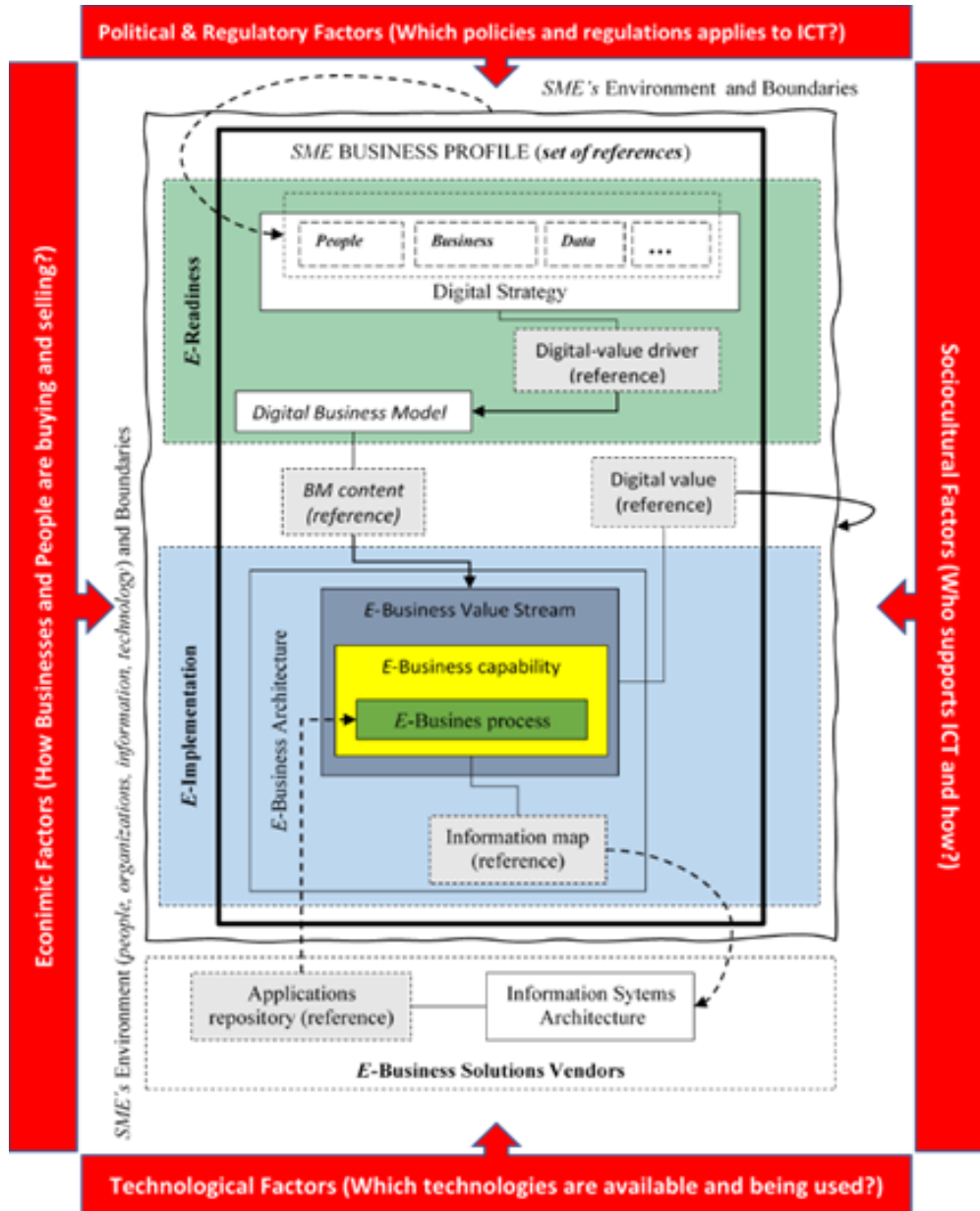

Adapted from: Putra & Hasibuan [3]

**Fourth**, within the *SMEs* business profile, we introduce two key components the business model content map and digital value map (a description of the digital offer) (cf. Figure 4.1). Also, we embodied a *deployment facet* into the *SMEs* environment - in this new facet, *SMEs* e-business solutions are designed, identified, or developed and deployed by (non-

technology) *SMEs* (cf. Figure 4.1). The *deployment facet* includes the Information Systems Architecture (*ISA*) building block and Applications repository component. Further details are out of the scope of this study.

So, for (*e-*)*implementation*, we agree on a technology-independent approach [3]. However, it's important to ensure that businesses systematically choose and adopt any available e-business technology and software application [14] in an evolutionary manner. To ensure the adaptability and *SME's* interoperability, the e-business information maps are used as a reference in the *ISA* of the specific industry – which provides application selection references for *SMEs'* e-businesses. While applications exist already in the *SMEs Context Applications Repositories*, suitable e-business applications can be instantiated into a specific *SME's* Business profile.

#### 4.2. CRITICAL ADOPTION'S FACTORS ANALYSIS

The context and motivation analysis are the processes of assessing the critical adoption factors from the *SME's* micro-environment. We posit that micro-environment is the most relevant context for *SMEs*; in this regard, we use the notion of *STEP* analysis. Furthermore, this analysis complements the internal *SWOT* analysis in the proceeding readiness assessment. Hence, former research reveals that *SME e-business* adoption factors (drivers or hinders) are not merely technology or economic related.

Table 4.1 Context Digital Elements vs. Influencing Factors Relationship Strengths

<b>CAFs Relationship's Strengths</b>		<b>CAFs Categories</b>			
		<b>Social</b>	<b>Technological</b>	<b>Economic</b>	<b>Political</b>
<b>CAFs Digital Elements</b>	Stakeholders ( <b>people</b> )	<i>Strongly related</i>		<i>Strongly related</i>	
	Organization ( <b>business</b> )			<i>Strongly related</i>	<i>Strongly related</i>
	Information (set of <b>data</b> )	<i>Strongly related</i>		<i>Strongly related</i>	
	Technology ( <b>cloud, IoT, etc.</b> )	<i>Strongly related</i>			

Here, the *STEP* analysis technique is extended mainly with the purpose of addressing (or assess) digital-related drivers [33] from the business environment digital elements. An *SME's* external and internal factors are often referred to as drivers and are equivalent to the

driver concept in the ArchiMate lexicon [15][18]. The outcomes of this analysis are registered in the Tables cells for future reference.

Hence, both analyses can be conducted for entire *SMEs*, products, or for a new venture (e.g., e-business, e-commerce, online presence, or partnership). For instance, we relate the threats and opportunities from outside with the strengths and weaknesses of an *SME*'s inside context to depict digital strategies (*cf.* Table 4.6).

Thus, this understanding leads to the following high-level hierarchical concepts in the *EA* perspective using the ArchiMate language. The process of critical adoption factors analysis should be realized by answering the following high-level questions, as those presented in the proposed framework for:

- 1) **Political or legal factors.** What are current or future policies and regulations regarding the *ICT* infrastructure, *ICT* education, trading, labor power, taxation, electronic transaction, data privacy?
- 2) **Economic factors.** How organizations and people are buying and selling in the industry or country?
- 3) **Technological factors.** Which technologies are available and being used, mainly for business purposes by organizations and people?
- 4) **Sociocultural factors.** Who supports and how technologies are supported by the people, in the social context for business purposes?

While addressing these questions in a broad way, one could find that the factors reportedly influence or are associated with the digital key elements; those relationships are depicted in the following Figure 4.3.

#### 4.2.1. MODELING A *SME*'S *CAFs* WITH ARCHIMATE

The above analysis of *CAFs* is the starting point for motivation formulation. So, in order to describe the *CAFs* surrounding the *SMEs*' motivation with ArchiMate, we rely on some of the *Motivation viewpoints*. Here we recommend the *Stakeholder viewpoint*, which – “allows [us] to model the stakeholders, internal and external drivers for change, and the assessments of these drivers” [11].

Figure 4.2 Hierarchical Concepts for Environment Assessment

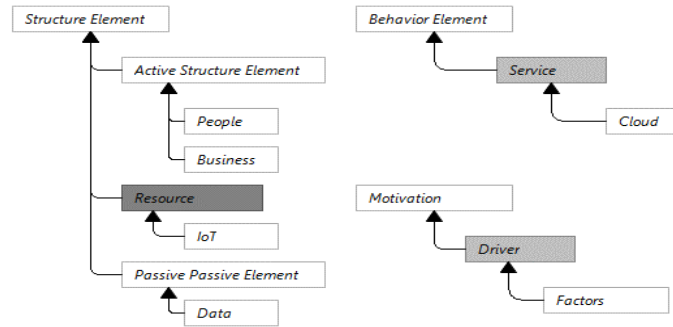

Table 4.2 Mapping of *SMEs' CAFs Relationships* in ArchiMate Lexicon

CAF's Relationships		CAF's Categories			
		Social	Technological	Economic	Political
CAF's Digital Elements	Stakeholders (people) <sup>i</sup>	Influence (d by)/Associated		Influence (d by)/Associated	
	Organization (business) <sup>ii</sup>			Influence (d by)/Associated	Influence (d by)
	Information (set of data)	Influence (d by)/Associated		Influence (d by)	
	Technology (cloud, IoT, etc.)	Influence (d by)/Associated			

This is a high-level overview of the *SMEs* environment, both inside and inside, addressed to senior management or decision-makers concerns; therefore, the *overview scope* of the content dimension is highly recommended. Also, as quoted above, an architecture view can be expressed with schemes and matrices; thus, the elaborated matrices of *CAF's analysis* shall complement and support effective communication with the stakeholders. Prior motivation modeling task is undertaken; we recommend that external *CAF's* are related to the internal factors due to *SWOT* analysis.

Table 4.3 Stakeholder Viewpoint Description

Stakeholder viewpoint	
<b>Stakeholders</b>	Stakeholders, business managers, business analysts, requirements managers
<b>Concerns</b>	Architecture mission and strategy, motivation
<b>Purpose</b>	Deciding, informing
<b>Scope</b>	Motivation
<b>Elements</b>	Stakeholder. Driver. Assessment. Goal. Outcome

Figure 4.3 *SMEs' CAFs and Stakeholders Motivations Mapping Meta-model*

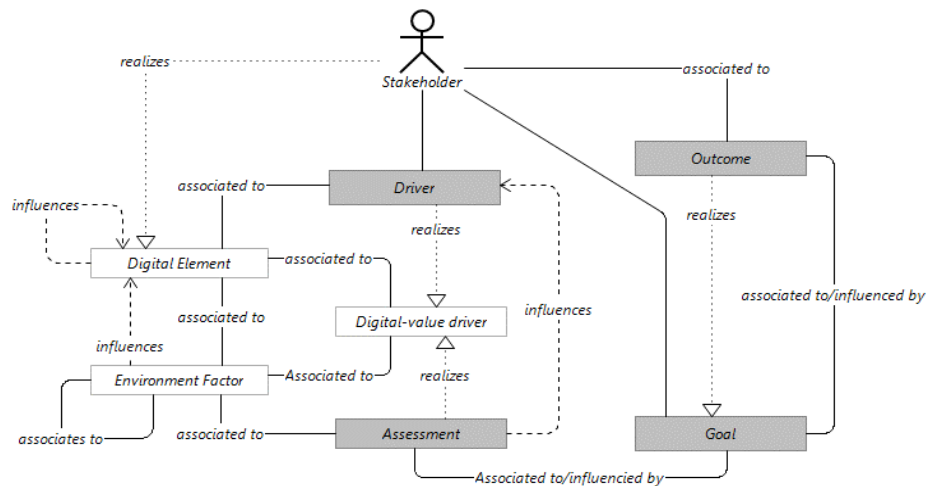

#### 4.3. READINESS ANALYSIS FOR A *SME*'S E-BUSINESS PROFILING

Adopting e-business is not a straightforward process; there are reported limitations of *SMEs* in implementing any existing e-business technologies [3]. Thus, having a handful of e-business technologies doesn't mean its implementation will be plug-and-play. *SMEs* need to have the proper motivation and be guided by a digital strategy.

Thus, at a high-level perspective of *SMEs* business, **motivations are translated into strategic intents** [33], namely: **position strategies, leverage strategies and opportunity strategies** [34]. *SMEs'* motivation arises from inside and outside context analysis. From the former critical adoption factors assessment of the external environment, some concerns (drivers) could be noticed as threats and opportunities. On the other hand, the internal *SME* context analysis regarding its strengths and weaknesses is fundamental to determine an *SME's* e-readiness. Therefore, we propose that *SWOT* analysis should be conducted aiming at relating the external aspects as threats and opportunities of former critical adoption factors with the internal aspects (weakness and strengths).

Performing *SWOT* analysis leads to a digital strategy, and this needs to be merged into the overall business strategy [35]. We state that the e-business strategy should be developed under the available resources and core capabilities related to digital key elements (e.g., people, business, data, *IoT*, cloud) [33]. This approach is important for the *SMEs* profiles granularity in the specific industry or country and, also to facilitate the alignment of strategic intents with the e-business models through digital-value drivers – “specific value-generating effects” [33] from the digital-related *SWOT* – which guides a specific digital strategy.

#### 4.3.1. *SWOT* ANALYSIS FOR *SMEs*’ PROFILING

The *SWOT* analysis supports the definition of a strategy and shall be conducted on the perspective of the digital key elements (*cf.* Table 4.6). Hence, every external factor associated with digital key elements is categorized in opportunities (O) and threats (T), and the internals are related to *SMEs*’ weaknesses (W) and strengths (S).

Table 4.4 An Example of Mapping Impacted Resources into the *CAFs* Analysis Matrix

<b><i>CAFs</i> Impacted Resources</b>		<b><i>CAFs</i> Categories</b>			
		<b>Social</b>	<b>Technological</b>	<b>Economic</b>	<b>Political</b>
<b><i>CAFs</i> Digital Elements</b>	Stakeholders ( <b>people</b> )	<i>Motivation; skills;</i>			
	Organization ( <b>business</b> )	<i>Reputation; culture;</i>		<i>Apparatus</i>	<i>Patents; copyright;</i>
	Information (set of <b>data</b> )				<i>Trade secrets;</i>
	Technology ( <b>cloud, IoT,</b> etc.)	<i>Technology;</i>			

Yet, prior *SWOT* analysis (*cf.* Table 4.4, Table 4.5), *SMEs* should evaluate which resources, capabilities are impacted or related to earlier assessed factors; so, we recommend this approach to keep *SMEs* decision-makers onboard before any architecture models are devised. Agreeing with [15], we classify resources as (1) tangible assets, (2) intangible assets, and (3) human assets, and from this standpoint, resources are explicitly related to digital key elements and micro-environment factors.

Table 4.5 An Example of Mapping impacted capabilities into the *CAFs* Analysis Matrix

<b>CAFs Impacted Resources</b>		<b>CAFs Categories</b>			
		<b>Social</b>	<b>Technological</b>	<b>Economic</b>	<b>Political</b>
<b>CAFs Digital Elements</b>	Stakeholders (people)				
	Organization (business)			Capacity for collaboration	
	Information (set of data)		Capacity for communication		Data management
	Technology (cloud, IoT, etc.)				

Following the mappings of resources and capabilities, the external opportunities and threats are related to internal strengths and weaknesses. This process is undertaken through an extended *SWOT* matrix for the translation of digital key elements and its related *SWOT*s into digital strategic options (*cf.* Matrix 4.6).

Table 4.6 Template for the Matching of *CAFs* Digital Elements related *SWOT* for Digital Strategy

<b>Digital Strategic Options</b>		<b>CAFs Digital Elements</b>	
		Related Weaknesses (W)	Related Strengths (S)
<b>CAFs Digital Elements</b>	Related Opportunities (O)	<i>Digital OW Strategy</i>	<i>Digital OS Strategy</i>
	Related Threats (T)	<i>Digital TW Strategy</i>	<i>Digital TS Strategy</i>

These digital-related *SWOT*s guide the digital strategy and are implicitly linked to the digital-value drivers. A digital strategy means a digital-oriented strategy of an *SME* related to specific 1) opportunities and weakness matching (**OW**) or, 2) opportunities and strengths matching (**OS**) or, 3) threats and weakness matching (**TW**) or, 4) threats and strengths matching (**TS**). For instance, each matching strategic option is related to one or more digital-value drivers in regard, and these digital value drivers to be cataloged into digital-value drivers' matrix [33] (*cf.* Table 4.7).

Moreover, while *SMEs'* e-business strategic intents and strategies are arranged as by Table 4.6, the digital business modeling process could follow the approach presented in [33] and depicted by Table 4.8. Following subsection 4.32 presents step by step on how to translate and match the strategic options with the business model, through internal or external digital-value drivers.

### 4.3.2. DIGITAL STRATEGIC OPTIONS TRANSLATION ONTO E-BUSINESS MODELS

Here, we use a matrix composed of *BMC* [19] components as columns and digital key elements as rows or vice versa (*cf.* Table 4.7). The matrix cells represent one or more digital-value drivers related to the chosen digital strategy and the design of the digital business model [33]. As these digital-value drivers could be generic rather than specific, one could refer the resulting digital business model as a *reference e-business model* for *SME* e-business adoption in this specific industry or country.

Hence, for specific *SME*'s digital-value drivers, we recommend that they shall be in four colors – green, yellow, red, and gray – heat map signing the e-readiness (generic) abstract gaps (*cf.* Table 4.7). These colors shall be understood as:

- **Green** – Signaling owned supporting capability, or competence, or resource for a specific value driver.
- **Yellow** – Signaling resources, capability, and competence to be enhanced to support the value driver.
- **Red** – Signaling important digital-value drivers in which an *SME* is required to acquire the supporting competence, capability, and resources.
- **Gray** – Signaling generic industry or business context's digital-value drivers.

Alignment between digital strategy and digital business model shall be by mean of the following digital-value drivers' cataloging matrix. For instance, one or more digital-value drivers of a chosen strategic option shall be related to the *BMC*' components (*cf.* Table 4.7).

Table 4.7 Digital-Value Drivers Cataloging and Head-Mapping Matrix Template

SME/Industry Digital-Value Drivers (D)		Business Model Canvas Components <sup>iii</sup>								
		VP	CSs	RS	CN	CR	KP	KR	KA	CS
CAFs Digital Elements	Stakeholders	<i>D<sub>1..n</sub></i>		----	----	----	----	----	<i>D<sub>1..n</sub></i>	<i>D<sub>1..n</sub></i>
	Organization	----	<i>D<sub>1..n</sub></i>	----	----	<i>D<sub>1..n</sub></i>	----	----	----	----
	Information	----	----	<i>D<sub>1..n</sub></i>	----	----	<i>D<sub>1..n</sub></i>	<i>D<sub>1..n</sub></i>	----	----
	Technology	----	----	----	<i>D<sub>1..n</sub></i>	----	----	----	----	----

Adapted from: Cigaina & Riss [33]

We posit that a **heat-map of digital-value drivers should guide on which business model to approach**. Rationally, *an SME shall decide in addressing a digital strategy, which is*

based on digital-value drivers mostly highlighted with Green and Yellow colors. However, we state an SME may well include Red and Gray colored digital-value drivers as the complement of the Green and/or Yellow colored digital-value drivers by which an SME's is ready to address for the e-business adoption process (cf. Table 4.7). In this case, an SME shall acquire any necessary resources, or competence, or capability to fulfill its goals. Following e-readiness analysis, the subsequent step shall be modeling the former tabular analyses with ArchiMate. This should result in work products (artifacts or views) such as:

- **Strategy map** guided by strategy viewpoint (cf. Table 4.9, Figure 4.4),
- Context *drivers' catalog* such as a matrix (cf. Table 4.6),
- And *business model diagram* guided by layered viewpoint (cf. Table 10, Figure 4.5) and Table 4.7.

Table 4.8 Template for the Translation of the Digital-Value Drivers into Business Models with Cost vs. Revenue Estimates

<b>Key Partnerships (KP)</b> <table border="1"> <tr><td><b>D<sub>1..n</sub></b></td></tr> <tr><td>Content's description</td></tr> <tr><td><b>D<sub>1..n</sub></b></td></tr> <tr><td>Content's description</td></tr> <tr><td>- \$</td></tr> </table>	<b>D<sub>1..n</sub></b>	Content's description	<b>D<sub>1..n</sub></b>	Content's description	- \$	<b>Key Activities (KA)</b> <table border="1"> <tr><td><b>D<sub>1..n</sub></b></td></tr> <tr><td>Content's description</td></tr> <tr><td>-\$</td></tr> <tr><td><b>D<sub>1..n</sub></b></td></tr> <tr><td>Content's description</td></tr> <tr><td>-\$</td></tr> </table>	<b>D<sub>1..n</sub></b>	Content's description	-\$	<b>D<sub>1..n</sub></b>	Content's description	-\$	<b>Value Proposition (VP)</b> <table border="1"> <tr><td><b>D<sub>1..n</sub></b></td></tr> <tr><td>Content's description</td></tr> </table>	<b>D<sub>1..n</sub></b>	Content's description	<b>Customer Relationships (Cr)</b> <table border="1"> <tr><td><b>D<sub>1..n</sub></b></td></tr> <tr><td>Content's description</td></tr> <tr><td>-\$</td></tr> <tr><td><b>D<sub>1..n</sub></b></td></tr> <tr><td>Content's description</td></tr> </table>	<b>D<sub>1..n</sub></b>	Content's description	-\$	<b>D<sub>1..n</sub></b>	Content's description	<b>Customer Segments (CSs)</b> <table border="1"> <tr><td><b>D<sub>1..n</sub></b></td></tr> <tr><td>Content's description</td></tr> <tr><td>+\$</td></tr> <tr><td><b>D<sub>1..n</sub></b></td></tr> <tr><td>Content's description</td></tr> </table>	<b>D<sub>1..n</sub></b>	Content's description	+\$	<b>D<sub>1..n</sub></b>	Content's description
	<b>D<sub>1..n</sub></b>																										
Content's description																											
<b>D<sub>1..n</sub></b>																											
Content's description																											
- \$																											
<b>D<sub>1..n</sub></b>																											
Content's description																											
-\$																											
<b>D<sub>1..n</sub></b>																											
Content's description																											
-\$																											
<b>D<sub>1..n</sub></b>																											
Content's description																											
<b>D<sub>1..n</sub></b>																											
Content's description																											
-\$																											
<b>D<sub>1..n</sub></b>																											
Content's description																											
<b>D<sub>1..n</sub></b>																											
Content's description																											
+\$																											
<b>D<sub>1..n</sub></b>																											
Content's description																											
<b>Key Resources (KR)</b> <table border="1"> <tr><td><b>D<sub>1..n</sub></b></td></tr> <tr><td>Content's description</td></tr> <tr><td>-\$</td></tr> </table>	<b>D<sub>1..n</sub></b>	Content's description	-\$	<b>Channels (CN)</b> <table border="1"> <tr><td><b>D<sub>1..n</sub></b></td></tr> <tr><td>Content's description</td></tr> <tr><td>-\$</td></tr> </table>	<b>D<sub>1..n</sub></b>	Content's description	-\$																				
<b>D<sub>1..n</sub></b>																											
Content's description																											
-\$																											
<b>D<sub>1..n</sub></b>																											
Content's description																											
-\$																											
<b>Cost Structure (CS)</b> <table border="1"> <tr><td><b>D<sub>1..n</sub></b></td></tr> <tr><td>Content's description</td></tr> <tr><td>Σ (-\$)</td></tr> </table>		<b>D<sub>1..n</sub></b>	Content's description	Σ (-\$)	<b>Revenue Streams (RS)</b> <table border="1"> <tr><td><b>D<sub>1..n</sub></b></td></tr> <tr><td>Content's description</td></tr> <tr><td>Σ (+\$)</td></tr> </table>			<b>D<sub>1..n</sub></b>	Content's description	Σ (+\$)																	
<b>D<sub>1..n</sub></b>																											
Content's description																											
Σ (-\$)																											
<b>D<sub>1..n</sub></b>																											
Content's description																											
Σ (+\$)																											

4.3.3. DESCRIBING THE SME'S READINESS WITH ARCHIMATE

The description task starts with the devising of a SMEs' motivation, as stated formerly in subsection 4.2.1. Like previous section modeling tasks, devising the SME's readiness models with ArchiMate addresses mainly of senior managers (or SME's owners) deciding purpose;

also, it shall aim the *designing purpose* of the next phase. Therefore, we propose viewpoints of the *overview* category as appropriate to guide the devising of the work products.

Also, as we illustrated in our proposed framework, the *E-Readiness* phase embodies multiple concepts and aspects, such as strategy (*strategy layer*), business model (*strategy, business layers*), digital-value drivers (*motivation aspect*). Therefore, we state that it is recommended to rely on multiple viewpoints to address the stakeholder’s concerns.

Table 4.9 Strategy Viewpoint Description

Strategy viewpoint	
<b>Stakeholders</b>	<i>SMEs owners, business managers, business architects</i>
<b>Concerns</b>	<i>Strategy development</i>
<b>Purpose</b>	<i>Designing, deciding</i>
<b>Scope</b>	<i>Strategy</i>
<b>Elements</b>	<i>Resource. Capability. Course of action. Outcome</i>

Figure 4.6. Translation of SWOT Analysis into Strategy View with ArchiMate

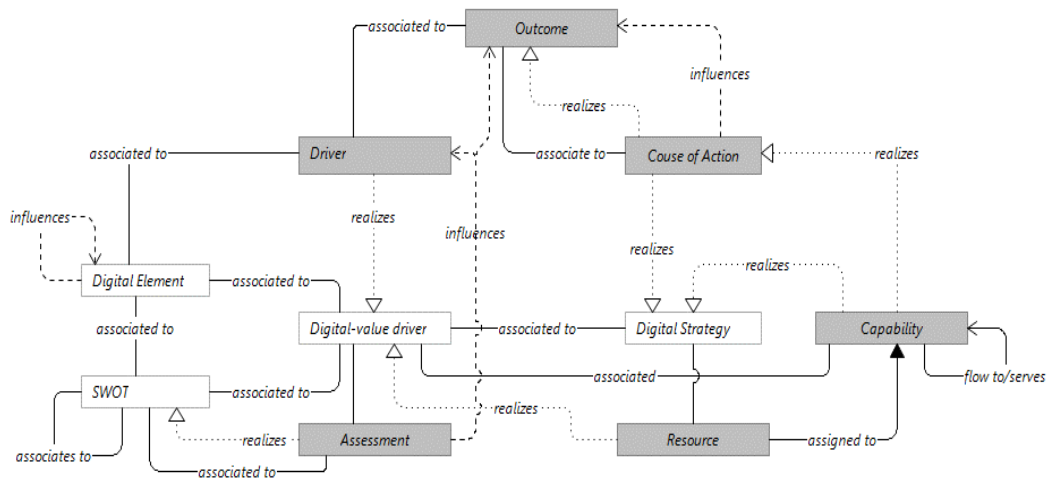

Digital key element related opportunity, or threat, or strength, or weakness translates into a digital-value driver and digital strategy; the above Figure 4.4. depicts the mapping of these concepts and their relationships with ArchiMate concepts.

Table 4.10 Layered Viewpoint Description

Layered viewpoint	
<b>Stakeholders</b>	<i>SMEs owners, and enterprise and process architects</i>
<b>Concerns</b>	<i>Consistency, reduction of complexity, the impact of change, flexibility</i>
<b>Purpose</b>	<i>Designing, deciding, informing</i>
<b>Scope</b>	<i>Multiple layers/Multiple aspects</i>
<b>Elements</b>	<i>Business actor. Business role. Stakeholder. Business service. Value. Product. Goal. Business interface. Resource. Business interaction. Capability. Business collaboration. Contract</i>

Figure 4.7 Business Model Diagram with Archimate Concepts

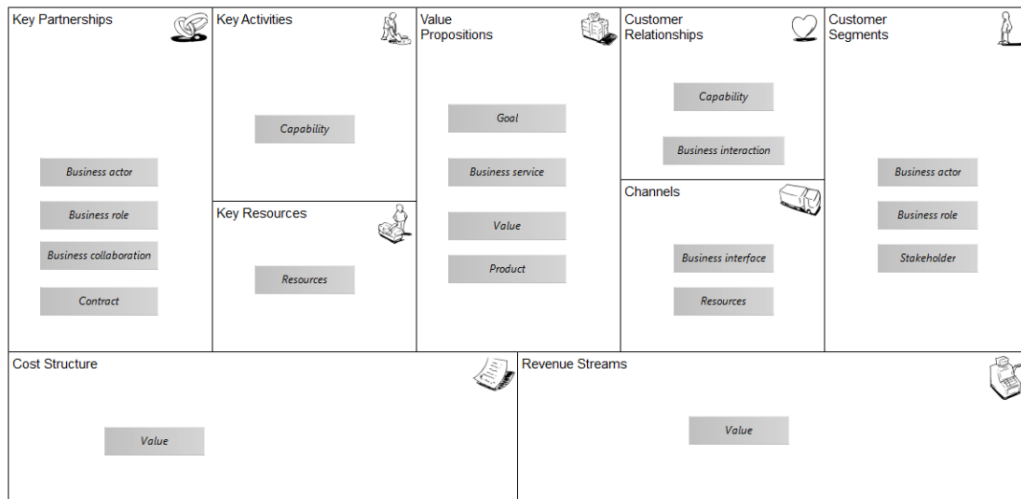

#### 4.4. IMPLEMENTATION APPROACH OF A SME'S E-BUSINESS

Our proposal takes a different approach from the baseline research [3] in this facet, as we stated earlier, a fine-grained e-business adoption pattern could be feasible for *SMEs*, particularly for those in developing countries. Hence, we adopt the value stream-based approach instead to ensure a non-siloed e-business adopt that could result in a value chain-based approach. Also, we rely on a technology-independent perspective, while we suggest the deployment facet to handle all aspects related to e-business systems architecture. This facet is all about the (*E*-)Business Architecture; here, we describe most of the core components of *BA*, except the organizational structure.

We demonstrate the translations of the *SMEs* business model in value-adding activities that support the value creation (internal context), delivery (external context), and capture

(internal). Also, afford to couple the value-adding activities with is realizing capabilities, relevant associated endeavor information. Therefore, we adopt the Value Stream Analysis Technique presented in subsection 2.1.3 to fulfill this purpose. Our approach for this facet aims at aligning the *SME's* strategic options (intents) with *SME's* e-business processes that will deploy the e-business system in an adaptive and evolutionary manner.

#### 4.4.1. E-BUSINESS ARCHITECTURE AS A REFERENCE MODEL

The *SME's* (e-)business architecture is driven by the (e-)readiness business model, which is developed through the business value to be delivered both internally and externally. Therefore, it needs to be a value-driven architecture, being the value streams reference models the starting point of the modeling process. Moreover, these capabilities and business processes can be realized with a combination of the organization (business), people, information (set of *data*), and technology (e.g., *cloud, IoT, etc.*)[15]. Therefore, we end-up with the following meta-model (*cf.* Figure 4.6).

Figure 4.8 Translation of Digital Business Model into E-Business Value Stream Map Meta-Model

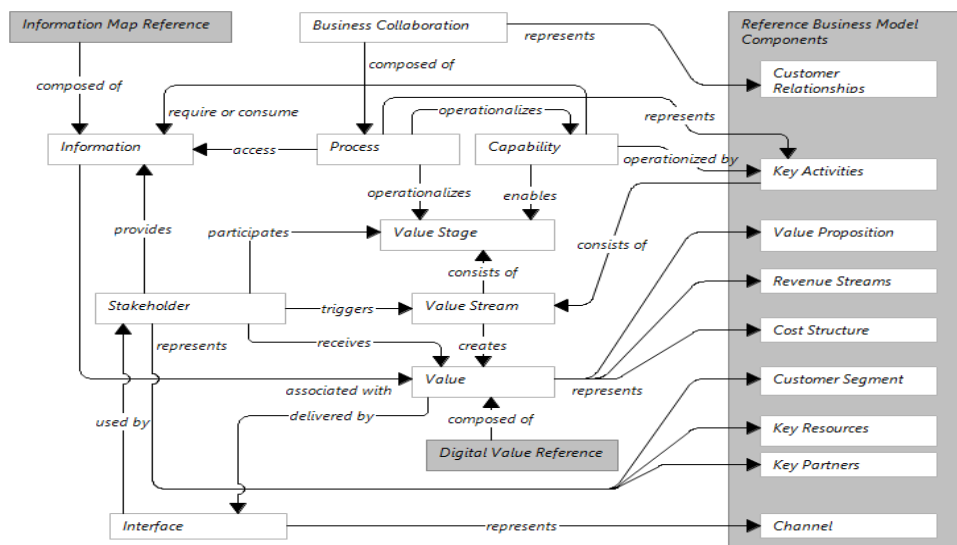

#### 4.4.2. METHODOLOGY FOR THE (E-)IMPLEMENTATION PHASE

Looking closely into the Putra & Hasibuan initial idea of a framework, it incorporates value-chain as the foundation for e-business adoption behavior evaluation. Also, this is the essence of an *SME's* full operating model. However, for implementation reference modeling, we use

Value Mapping Analysis [26] methodology introduced in the subsection 2.1.3, to ensure that siloed activities in the *SME*'s value chain Impact in a stream of value-adding activities.

**First.** Based on the customer value proposition, we define a – value-stream for one specific value – within the primary and/or supporting activities of the *SME*'s value chain. The value stream is named as by the value proposition and decomposed into essential activities (stages) orderly undertaken to create, deliver, and capture value; here we use Table 2.1. For instance, one shall answer the following questions[36]:

- 1) *Who are the target customers?*
- 2) *What does need to be done to solve an important problem or fulfill an important customer need?*
- 3) *What do we offer to satisfy the customers' needs or to solve the problem?*

**Second.** Stakeholders triggering a value stream, both internal (e.g., Employees) or external (e.g., Customers, suppliers, or partners) and value partitions (value items), are associated with specific value stream stages. The entry and exit criteria for each value stream stage are defined using Table 2.2.

**Third.** Each value stream stage is mapped to one or more capabilities, or granularly to one or more processes using Table 2.3. These processes are later described in an (e-)business process model (set of logically and orderly executed activities)[26].

**Fourth.** Hence, as (e-)business capabilities and processes produce and consume information for the value delivery; this requires that higher-level business concepts are extracted and mapped for each value stream stage; so, we use Table 2.4. A glossary of business concepts is elaborated, and the concepts mutually related [27] in tabular format and later diagrammatically mapped. These business concepts in relationship represent the business objects, initially collected along with definition and synonyms. The information concept is categorized in *Primary* for high-level business concepts or *Secondary* for its derivative business concepts.

**Fifth.** Devise (e-)business architecture models of the former steps with ArchiMate. This model, as a reference shall include the following artifacts:

- 1) Value stream model guided by the Business process cooperation viewpoint (*cf.* Table 4.11).
- 2) Value stream and capability map guided Layered viewpoint (*cf.* Table 4.10) restricted on strategy and business layer.

- 3) Information map guided by Information structure viewpoint (*cf.* Table 4.13)
- 4) Value map, and optionally guided by Product viewpoint (*cf.* Table 4.12)
- 5) Business process model guided by the Business process cooperation viewpoint (*cf.* Table 4.10).

#### 4.4.3. DESCRIBING THE (E-)IMPLEMENTATION WITH ARCHIMATE

The proposed description of this facet of an *SME's* e-business with ArchiMate regards devising the core architecture views of our *BA*. This architecture views mainly describes the business layer of the ArchiMate framework and aims to demonstrate the alignment of the *SME's* strategic intent with the business processes. Using value stream mapping technique to devise the value creation, delivery, and capturing process, we easily position our viewpoint at the design and decision-making, i.e., the *designing and deciding purpose*. Here, we want to demonstrate how the value proposition or product is packaged and channeled to customers and all related responsibilities.

Table 4.11 Business Process Cooperation Viewpoint Description

<b>Business Process Cooperation Viewpoint</b>	
<b>Stakeholders</b>	<i>Operational managers, Process and domain architects</i>
<b>Concerns</b>	<i>Dependencies between business processes, consistency and completeness, responsibilities</i>
<b>Purpose</b>	<i>Designing, deciding</i>
<b>Scope</b>	<i>Multiple layer/Multiple aspect</i>
<b>Elements</b>	<i>Business actor. Business role. Business collaboration. Location. Business interface. Business process/function/interaction. Business event. Business service. Business object. Representation. Application component/collaboration. Application interface. Application process/function/interaction. Application event. Application service. Data object</i>

The design should be related to the business process owners, and we recommend that the *Business process cooperation viewpoint, the Information structure, and Product viewpoint* are suitable to illustrate these concerns. On the other hand, a multiple layer relationship at the *coherence level* is necessary to demonstrate how the business processes are related to *SME's* resources and capabilities at the strategy layer.

Table 4.12 Information Structure Viewpoint Description

<b>Information Structure Viewpoint</b>	
<b>Stakeholders</b>	<i>Domain and information architects</i>
<b>Concerns</b>	<i>Consistency, reduction of complexity, the impact of change, flexibility</i>
<b>Purpose</b>	<i>Designing, deciding, informing</i>
<b>Scope</b>	<i>Multiple layers/Multiple aspects</i>
<b>Elements</b>	<i>Business actor. Business role. Stakeholder. Business service. Value. Product. Goal. Business interface. Resource. Business interaction. Capability. Business collaboration. Contract</i>

Table 4.13 Product Viewpoint Description

<b>Product Viewpoint</b>	
<b>Stakeholders</b>	<i>Product developers, product managers, process and domain architects</i>
<b>Concerns</b>	<i>Product development, the value offered by the products of the enterprise</i>
<b>Purpose</b>	<i>Designing, deciding</i>
<b>Scope</b>	<i>Multiple layers/Multiple aspects</i>
<b>Elements</b>	<i>Business actor. Business role. Business collaboration. Business interface. Business process/function/interaction. Business event. Business service. Business object. Product. Contract. Application component/collaboration. Application interface. Application process/function/interaction. Application event. Application service. Data object. Technology service. Artifact. Material. Value</i>

#### 4.5. BEYOND THE SME'S E-BUSINESS ARCHITECTURE

Mapping deployed *E-business* applications falls at lower layer beyond the business layer of the ArchiMate framework. We posit that *e-business technologies adoption* involves not only an SME capability to adopt specific technology, but also other context or industry players.

Table 4.14 E-Business Process Vs. E-Business Systems Mapping

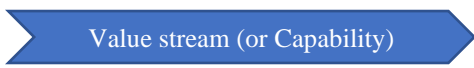
<b>E-Business Information Entities</b>						
		<b>Stage<sub>1</sub></b>	<b>Stage<sub>2</sub></b>	<b>Stage<sub>3</sub></b>	<b>...</b>	<b>Stage<sub>n</sub></b>
<i>E-Business Systems<sub>1...N</sub></i>	<b>System<sub>1</sub></b>	<i>E<sub>1..n</sub></i>			<i>E<sub>1..n</sub></i>	
	<b>System<sub>2</sub></b>		<i>E<sub>1..n</sub></i>			
	<b>...</b>			<i>E<sub>1..n</sub></i>		<i>E<sub>1..n</sub></i>
	<b>System<sub>n</sub></b>	<i>E<sub>1..n</sub></i>			<i>E<sub>1..n</sub></i>	

Therefore, we propose the *deployment* facet dealing with context *e-business solution vendors outside* of a (non-technology) *SME's boundaries*. For instance, for analysis purposes only, one could use the following Table 4.1 as the start point of e-business solutions architecture. This matrix relates the value stream stages (activities) with the corresponding applications through involved e-business information concepts (entities). However, developing this topic falls out the scope of this study.

## **Chapter 5. DEMONSTRATION**

## SYNOPSIS

In the following section, we are demonstrating the application of our proposed framework in designing e-business reference models. The demonstration herein is based on a case study of a fictitious traditional marketing agency in Mozambique, a developing country.

### 5.1. CASE STUDY OF A TRADITIONAL SME: *MERKATOS*

This case study is based on a fictitious Marketing Agency – *Merkatos*. This is an *SME* operating in the marketing industry in Mozambique, to provide traditional mass media marketing services for diverse business sectors, mainly brick-and-mortar retailers. *Merkatos'* core competencies are the production and publishing of graphical, audio, and video marketing content. For 10 years *Merkatos* has built an affordable client's loyalty portfolio. Since 2017, *Merkatos* is seeking to capitalize on the industry opportunity through the internet potentials aiming to scale across the country. *Merkatos* has 10 employees, three are photographers and graphic designers, one marketing and public relations manager, one finance and administration officer, and five field agents or representatives, and the general manager (owner).

Recently, Mozambique has adopted *ETA*, and the country sees a growing internet usage index for the last five years. Moreover, all mobile network operators offer an aggregated mobile banking service for subscribers, and although technology literacy in Mozambican is low, mostly 80% of urban mobile network subscribers have access to smartphones. Physical store owners are using non-traditional channels to keep in contact with regular customers via social networking platforms (e.g., WhatsApp, Facebook, etc.). Also, shoppers started using the same means to share information related to promotional and limited-edition products.

*Merkatos* office has one fixed-line IP Phone, and one wireless router connects to the internet through the local landline network operator. All Personal Computers in the office connect to the internet through an installed router, and the designers are using *cloud storage services* to store and share multimedia contents. Additionally, *Merkatos'* field representatives' daily work includes assembling a stand equipped with powerful speakers and memory card readers or a laptop to play advertisements in public squares.

Moreover, the representatives used to operate stands in crowded public places, and sometimes they distribute print advertisements or by posting in billboards or walls. Yet, this

is a common practice of most competitors. Since 2015, Mozambique is facing an economic deficit leading to a 19.1% inflation rate in 2016<sup>iv</sup>. Therefore, *Merkatos* decision-makers are looking to “reduce 3% of publishing costs”, and enhance the market access for premium customers to increase profit by 1% by third Quarter (Q3) in 2020.

*Merkatos* expenditures on multimedia channels are 25% off quarterly budget. Despite the company’s need to continue using the mass media to reach audiences randomly, the business owner understands the potential of the internet as a substitute and how it facilitates new entrants and is looking to seize an opportunity of high demanding customers. Through the scenario depicted in this case, we will demonstrate how to implement the proposed framework to devise an e-business adoption reference models for SMEs in this country.

#### 5.1.1. MERKATOS’ CRITICAL ADOPTION FACTORS DESCRIPTION

The above case study scenario alludes to some of the *Merkatos* macro-environment critical factors for digital enacted businesses adoption. The following Table 5.1 presents a summarized view of these factors. This managerial analysis of *Merkatos external* context was complemented by *SWOT* analysis in the following subsection 5.1.2. By coupling the inside and outside state of affairs, *Merkatos* envisioned the *business motivations* and depicted the strategic options.

Table 5.1 *Merkatos*' CAFs Analysis over Cross-Industry Digital Elements

Merkatos Context CAFs		CAFs Categories			
		Social	Technological	Economic	Political
CAFs Digital Elements	Stakeholders (people)	- <i>Low technology literacy.</i> - <i>Social networking.</i>	- <i>Growing internet access</i> - <i>Digital consumers</i> - <i>Mobile banking</i>	- <i>Low income.</i> - <i>High inflation rate</i>	- <i>Adoption ETA.</i> -
	Organization (business)	-	- <i>Growing internet access</i> - <i>Connected partners</i> - <i>Data and content providers</i>	- <i>High inflation rate.</i> -	- <i>Adoption of ETA.</i> -
	Information (set of data)	- <i>People network effect</i> - <i>People share information openly</i>	-	-	- <i>Data privacy enforcement by ETA</i>
	Technology (cloud, IoT, etc.)	-	- <i>Business usage of cloud storage.</i> - <i>Social network-based solutions</i>	- <i>Adaptive pricing</i> - <i>Lower Marginal costs of digital assets</i>	-

### 5.1.2. MERKATOS' E-READINESS EVALUATION

The process of building an *SME*'s profile for e-business begins with an e-readiness evaluation, as we stated in the former section 4.3. Herein, from the former Table 5.1, we related the external factors with the internal strengths and weaknesses in a digital context; this process led the depiction of diverse digital strategic options for *Merkatos*. Our analysis over *Merkatos E-Readiness* began with the following matrices showing how the formerly identified factors (*cf.* Table 5.1) impact internal resources and capabilities (*cf.* Table 5.2, Table 5.3).

Here we found that *Merkatos*' internal stakeholders (employees) ***digital skills were being negatively influenced by low technology literacy***, and this social factor hinds *Merkatos* ability to hire digitally skilled employees. Also, we found that internet access growth in the

country influences *Merkatos ability to communicate and safely store multimedia content* into the *cloud* through internet technology.

Also, the economic factors like high inflation rate affect *Merkatos ability to Manage Inventory for advertisements*, which also affects its *capabilities for collaboration with digital marketing experts* and systems vendors. For Merkatos, customer loyalty is a core resource, and an economic factor as a **high inflation rate affects price conscience customers**.

Table 5.2 Mapping of *Merkatos' CAFs Impacted Resources*;

Merkatos' Impacted Resources by CAFs		CAF's Categories			
		Social	Technological	Economic	Political
CAF's Digital Elements	Stakeholders (people)	- Digital skills;	-	-	-
	Organization (business)	-	-	- Customer loyalty.	- Copyright;
	Information (set of data)	-	-	-	-
	Technology (cloud, IoT, etc.)	-	- Technology (PCs, cloud storage);	-	-

Table 5.3 Mapping of *Merkatos' CAFs Impacted Capabilities*;

Merkatos' Impacted Capabilities by CAFs		CAF's Categories			
		Social	Technological	Economic	Political
CAF's Digital Elements	Stakeholders (people)	-	-	-	-
	Organization (business)	-	-	- Collaboration capability - Inventory management	-
	Information (set of data)	-	-	-	- Content management
	Technology (cloud, IoT, etc.)	-	- Communication capability;	-	-

Additionally, the political factors related to a new *ETA* affect **positively intellectual propriety protection** over Merkatos digital content. However, *digital privacy enforcement affects Merkatos digital content management capability*.

The following matrix shows how *Merkatos* relevant *SWOT* related to digital elements guide the development of its strategic options for e-business adoption. For each strategic e-business

option, we found the associated digital value drivers; therefore, the following Table 5.5 provides us with the industry and *Merkatos* business context digital value drivers.

Though, before we present the *Merkatos* industry digital value drivers' catalog, let us present the leading *Merkatos* business motivation model (cf. Figure 5.1).

Moreover, *Merkatos* has decided to pursue an *Opportunity Strategic Intent* with *Digital OS Strategy* – “Develop a digital content marketing channel.” This choice is depicted in Figure 5.2.

Table 5.4 Matching of *CAFs* Digital Elements with its Related *SWOTs* to Develop Digital Strategy

		<b>CAFs Digital Elements (People, Business, Data, Cloud)</b>	
		<b>Related Weaknesses (W):</b>	<b>Related Strengths (S):</b>
<b>Merkatos' Digital Strategic Options to Reduce Cost</b>		<b>Related Weaknesses (W):</b> - Personnel (employees) with limited digital skills;	<b>Related Strengths (S):</b> - Expertise in multimedia production; - Knowledgeable of digital content management; - Competent in social media platforms
<b>CAFs Digital Elements (People, Business, Data, Cloud)</b>	<b>Related Opportunities (O):</b> - Socially networked people; - Internet-connected businesses; - Low publishing costs	<b>Digital OW Strategy:</b> - Collaborate with Internet marketers to publish digital ads.	<b>Digital OS Strategy:</b> - Develop a digital content marketing channel. - Provide a market access channel for 24/7 availability.
	<b>Related Threats (T):</b> - Low technology literacy; - The high cost of data services;	<b>Digital TW Strategy:</b> - Partner with operators for SMS marketing.	<b>Digital TS Strategy:</b> - Develop a social media channel targeting local subscribers only.

Figure 5.1 *Merkatos E-Business Motivation Model Description*

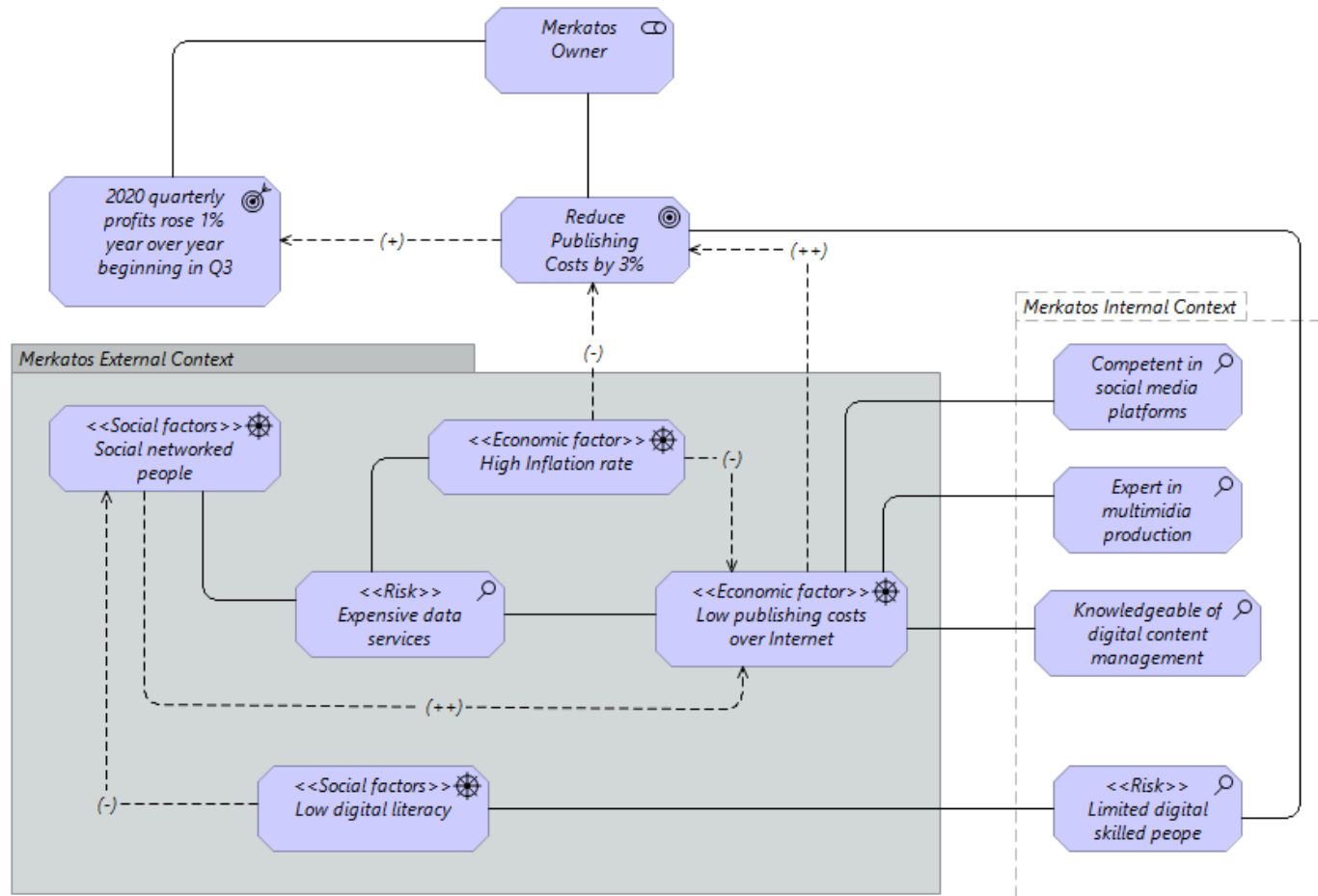

Table 5.5 *Merkatos'* Industry Digital-Value Drivers' Catalog

Merkatos Digital-Value Drivers		BMC Components								
		Value proposition	Customer segments	Revenue streams	Channels	Customer relationships	Key partners	Key resources	Key activities	Cost structure
CAFs Digital Elements (Instances)	people	<i>Social network-based solutions</i>	<i>Digital consumers</i>		<i>Digital access points as a channel</i>	<i>Social network-based customer relationships</i>				<i>People network effect</i>
	business					<i>Business network-based customer relationships</i>	<i>Connected partners</i>			<i>Cost reduction by digital make-or-buy flexibility</i>
	cloud								<i>Social Media Marketing</i>	<i>Lower Marginal costs of digital assets</i>
	data		<i>Customers with high Information demands</i>	<i>Adaptive pricing</i>	<i>Customized channels</i>	<i>Better knowledge of customers</i>	<i>Data and content providers</i>	<i>Data as a resource</i>	<i>Data Management</i>	

Table 5.5 presents the industry generic digital-value drivers reference catalog. Thus, any *SME*'s operating in this business context could find its matching digital strategic options and heatmap patterns. In the case of *Merkatos*, this matrix guided the design of any baseline e-business model at the final stage of *Merkatos* e-readiness analysis. For instance, below, we are presenting one out of many *Merkatos* possible business models for e-business adoption. ***Merkatos* has identified those digital-value drivers and chosen some as lead drivers translated in E-business models contents** (cf. Table 5.6).

### **An overview of *Merkatos* Business Model**

Through the *SWOT* analysis and the identified industry digital drivers, *Merkatos* has a business case supporting its strategic options. The chosen strategic option cost and revenue estimation are depicted on a Quarterly basis. Now, we need to recall the meaning of the colored cells in this scenario.

At *Merkatos*, they are making decisions on their core recourses, and capabilities that will support the realization of the drivers. *Merkatos* decided to upskill its personnel for digital content management in order to produce and publish advertisements – available 24/7 via social media. A strict target group of 20-to-45-year-old, in Maputo City, has been identified. Also, they decided to upskill competencies for Data Management.

*Merkatos* general manager is considering actual Internet Service Providers (*ISP*) as prospect partners to acquire mobile subscribers' internet access indicators. However, *Merkatos* is concerned with the acquisition of new competencies for customer relationships through social media.

Also, the firm is concerned with access to new digital resources for the delivery of its new value proposition. *Merkatos* decision-makers are deciding to approach the adaptive pricing to address price conscience customers due to the high inflation rate. Moreover, they are confident about the cost reduction advantage of online advertisement – Single Ads Page for millions of consumers. Henceforward, the e-readiness profile is compiled, *Merkatos* decide to adventure on the e-business architecture process. To pursue its goal, the designed e-business model guides this new endeavor. So, the reader needs to remember that *Merkatos* is not changing its full length of activities.

Table 5.6 *Merkatos E-Business Model with Estimated Quarterly (Q) Cost vs. Revenue*

KEY PARTNERS		KEY ACTIVITIES		VALUE PROPOSITION	CUSTOMER RELATIONSHIPS		CUSTOMER SEGMENTS																							
<table border="1"> <tr><td colspan="2">Connected partners</td></tr> <tr> <td><i>ISP</i></td> <td><b>-\$1200/Q</b></td> </tr> </table>		Connected partners		<i>ISP</i>	<b>-\$1200/Q</b>	<table border="1"> <tr><td colspan="2"><b>Social media marketing</b></td></tr> <tr> <td>- Develop &amp; manage media campaigns</td> <td><b>-\$1000/Q</b></td> </tr> <tr> <td>- Manage social media</td> <td><b>-\$3500/Q</b></td> </tr> </table>		<b>Social media marketing</b>		- Develop & manage media campaigns	<b>-\$1000/Q</b>	- Manage social media	<b>-\$3500/Q</b>	<table border="1"> <tr><td colspan="2"><b>Social network-based solutions</b></td></tr> <tr> <td colspan="2">Advertise product/services' Online.</td> </tr> </table>	<b>Social network-based solutions</b>		Advertise product/services' Online.		<table border="1"> <tr><td colspan="2"><b>Social network-based customer relationships</b></td></tr> <tr> <td colspan="2">Friendship Circle with Consumers on social media platforms.</td> </tr> </table>		<b>Social network-based customer relationships</b>		Friendship Circle with Consumers on social media platforms.		<table border="1"> <tr><td colspan="2"><b>Digital consumers</b></td></tr> <tr> <td colspan="2">People of 20-45 years old subscribing social media platforms, in Maputo.</td> </tr> </table>		<b>Digital consumers</b>		People of 20-45 years old subscribing social media platforms, in Maputo.	
Connected partners																														
<i>ISP</i>	<b>-\$1200/Q</b>																													
<b>Social media marketing</b>																														
- Develop & manage media campaigns	<b>-\$1000/Q</b>																													
- Manage social media	<b>-\$3500/Q</b>																													
<b>Social network-based solutions</b>																														
Advertise product/services' Online.																														
<b>Social network-based customer relationships</b>																														
Friendship Circle with Consumers on social media platforms.																														
<b>Digital consumers</b>																														
People of 20-45 years old subscribing social media platforms, in Maputo.																														
<table border="1"> <tr><td colspan="2"><b>Data and content providers</b></td></tr> <tr> <td colspan="2">Social media platforms providers</td> </tr> </table>		<b>Data and content providers</b>		Social media platforms providers		<table border="1"> <tr><td colspan="2"><b>KEY RESOURCES</b></td></tr> <tr><td colspan="2"><b>Data as a resource</b></td></tr> <tr> <td>Social media subscribers' profiles</td> <td><b>-\$5000/Q</b></td> </tr> </table>		<b>KEY RESOURCES</b>		<b>Data as a resource</b>		Social media subscribers' profiles	<b>-\$5000/Q</b>		<table border="1"> <tr><td colspan="2"><b>CHANNELS</b></td></tr> <tr><td colspan="2"><b>Customized channels</b></td></tr> <tr> <td colspan="2">Social media platforms</td> </tr> </table>		<b>CHANNELS</b>		<b>Customized channels</b>		Social media platforms		<table border="1"> <tr><td colspan="2"><b>Customers with high Information demands</b></td></tr> <tr> <td>Retailers</td> <td><b>+\$17500/Q</b></td> </tr> </table>		<b>Customers with high Information demands</b>		Retailers	<b>+\$17500/Q</b>		
<b>Data and content providers</b>																														
Social media platforms providers																														
<b>KEY RESOURCES</b>																														
<b>Data as a resource</b>																														
Social media subscribers' profiles	<b>-\$5000/Q</b>																													
<b>CHANNELS</b>																														
<b>Customized channels</b>																														
Social media platforms																														
<b>Customers with high Information demands</b>																														
Retailers	<b>+\$17500/Q</b>																													
<b>COST STRUCTURE</b>					<b>REVENUE STREAMS</b>																									
<table border="1"> <tr><td colspan="4"><b>Lower Marginal costs of digital assets</b></td></tr> <tr> <td>Single Ads' Page for Millions of Subscribers.</td> <td colspan="3"><b>∑(-\$) = -10700/Q</b></td> </tr> </table>					<b>Lower Marginal costs of digital assets</b>				Single Ads' Page for Millions of Subscribers.	<b>∑(-\$) = -10700/Q</b>			<table border="1"> <tr><td colspan="4"><b>Adaptive pricing</b></td></tr> <tr> <td>Charges based on Ads' Page Visualization Trends</td> <td colspan="3"><b>∑(+\$) = 17500/Q</b></td> </tr> </table>				<b>Adaptive pricing</b>				Charges based on Ads' Page Visualization Trends	<b>∑(+\$) = 17500/Q</b>								
<b>Lower Marginal costs of digital assets</b>																														
Single Ads' Page for Millions of Subscribers.	<b>∑(-\$) = -10700/Q</b>																													
<b>Adaptive pricing</b>																														
Charges based on Ads' Page Visualization Trends	<b>∑(+\$) = 17500/Q</b>																													

## Completing the readiness evaluation

Evaluating readiness for change should comprise many readiness factors and criteria. And business independently defines their set of factors and criteria, through vision, desire, willingness and resolves, funding, and more. Therefore, from the motivation model due to the business model funding *Merkatos* has demonstrated its desire and willingness, and they are resolved to undergo the *E-business implementation* endeavor. So, at the high-level perspective of *Merkatos E-readiness profile*, we have additional architecture models.

Figure 5.2 *Merkatos' E-Business Digital Strategy Model*

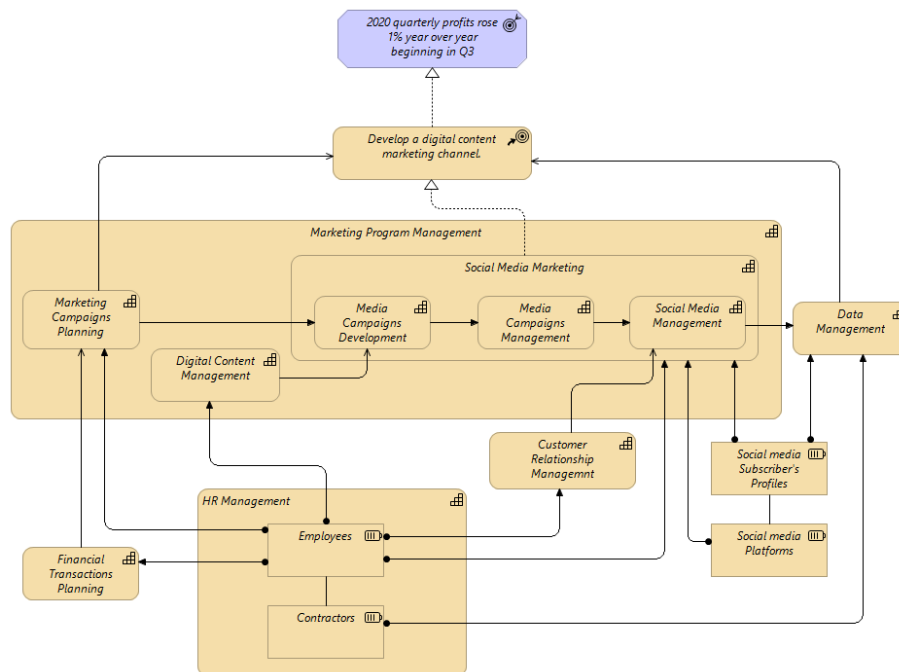

Following, we present the *Merkatos Business model diagram* (cf. Figure 5.3). Though a complete profile of *Merkatos E-Readiness Evaluation References* comprises:

- *CAFs* Analysis matrix
- *SWOT* Analysis matrix
- Motivation Model
- Digital-Value Drivers Catalog
- Strategic Intent Diagram
- Business Model Description and Diagram.

Figure 5.3 *Merkatos' E-business Model Diagram*

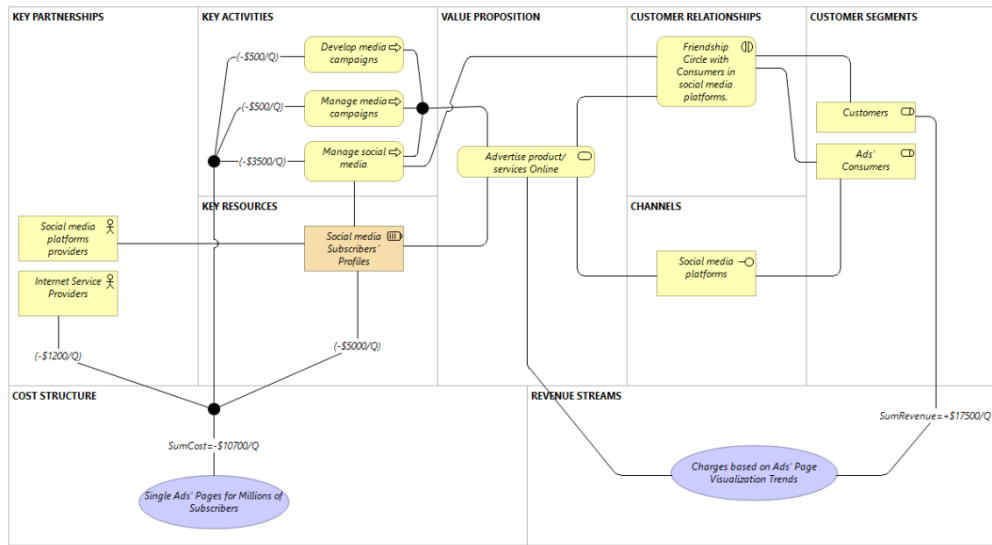

### 5.1.3. MERKATOS' E-BUSINESS IMPLEMENTATION DESCRIPTION

This stage encapsulates the core components of *Merkatos* e-business reference modeling. Like any *SME* using our framework, the implementation profiling begins with the translation of the *Key activities* of the *E-business model* (cf. Table 5.6, Figure 5.3) onto value streams, relating to the value proposition. *Merkatos'* customer value proposition for end-consumers is providing customers with local products and service information anywhere at any time - online.

For instance, one of the *Merkatos* Key activity is *Managing social media* – described in [37] – which requires upskills for its fulfillment. This new capability is coupled with *Merkatos* extant capability *Development and management of media campaigns*, also described in [37]. These core capabilities were translated onto the following value-adding activities:

- 1) Plan marketing program
- 2) Build a social media channel
- 3) Manage the marketplace Ads
- 4) Engage with consumers online
- 5) Measure and feedback

In addition, *Merkatos'* value stream was named – *Advertising Online*, and the value stream stages are the activities listed above.

Table 5.7 *Merkatos'* Value Stream Definition

<b>Name</b>	<b>Advertising Online</b>
<b>Description</b>	<i>Delivery of product/service promotional information on social media channels.</i>
<b>Stakeholders</b>	<i>Retail store wishing to advertise and social media subscribers (End-consumers)</i>
<b>Value</b>	<i>People can see product/services Ads online</i>

The following matrix illustrates the description of *Merkatos* value stream stages.

Table 5.8 *Merkatos'* Value Stream Decomposition

<b>Advertising Online</b>					
<b>Value stream stages</b>	<b>Description</b>	<b>Participating stakeholders</b>	<b>Entrance criteria</b>	<b>Exit criteria</b>	<b>Value item</b>
<i>Plan marketing campaigns</i>	<i>The act of defining the strategy, objectives, and metrics of the Marketing campaigns.</i>	<i>Retailer, Marketing Manager, Finance Clerk</i>	<i>Customer looking for Advertising plan.</i>	<i>Customer Engage with Merkatos</i>	<i>Ads campaign plans available to the customer.</i>
<i>Build a social media channel</i>	<i>The act of building a social media marketing channel like Facebook pages</i>	<i>Retailer, Marketing Manager, Content designer</i>	<i>The customer selects the Ads plan.</i>	<i>Customer Approves channels</i>	<i>Social media channel available to customer</i>
<i>Manage the marketplace Ads</i>	<i>The act of producing digital content, uploading, and posting the Ads.</i>	<i>Retailer, Marketing Manager, Content designer</i>	<i>Customer Approves channels.</i>	<i>Customer approves Ads contents</i>	<i>Online Ads visibility</i>
<i>Engage with end-consumers online</i>	<i>The act of promoting Ads and interacting with social media subscribers (consumers)</i>	<i>Social media subscriber, Marketing Manager, Content Promoter</i>	<i>Customer approves the publishing of Ads' contents</i>	<i>Consumer engages with Ads contents</i>	<i>Consumers' brand awareness rate.</i>
<i>Measure and feedback</i>	<i>The act of evaluating the marketing channel's performance and Optimization.</i>	<i>Marketing Manager, Retailers, Content designers</i>	<i>Consumer engages with Ads contents</i>	<i>Customer receive Feedback</i>	<i>Customer intimacy rate.</i>

Figure 5.5 Merkatos E-Business Value Stream Map Coupled with a bundled Reference Digital Value

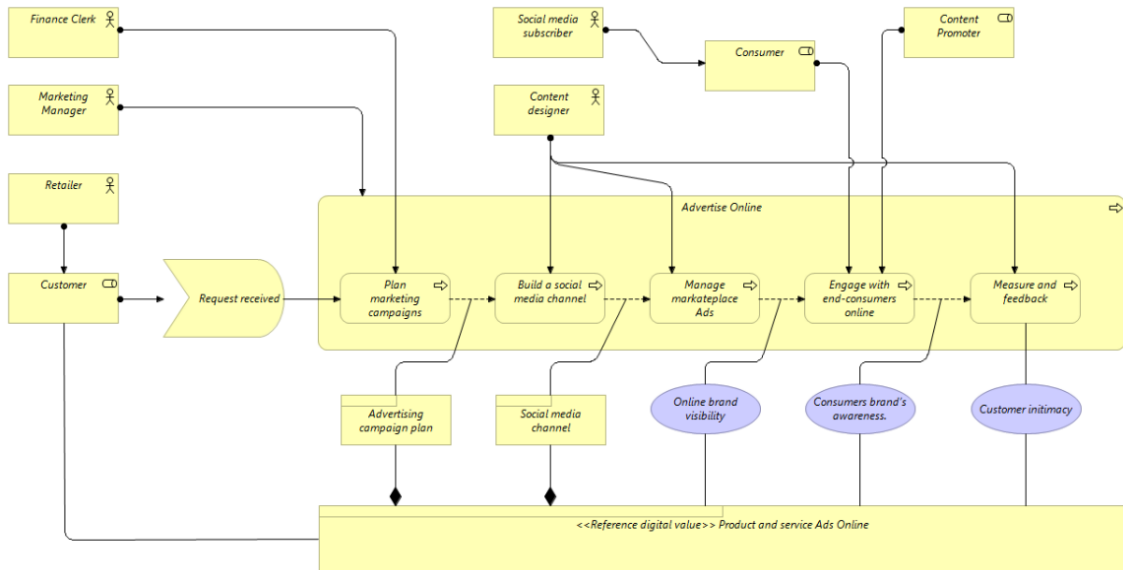

Now, since the value stream stages have been described, the participating stakeholders and outcome values partition are known. It became explicit which capabilities and business concepts are used to realize the business value. Figure 5.4 depicts *Merkatos E-business value stream*, and this model helps *Merkatos managers on understanding how different business process and stakeholders interact either to produce value or to receive value*.

Table 5.9 Merkatos Value Stream and Capabilities Mapping

Advertising Online				
Plan marketing campaigns	Build a social media channel	Manage marketplace Ads	Engage with end-consumers online	Measure and feedback
<b>Capability</b>	<b>Capability</b>	<b>Capability</b>	<b>Capability</b>	<b>Capability</b>
<div style="background-color: yellow; padding: 2px;">Marketing Campaigns Planning</div> <div style="background-color: green; padding: 2px;">Financial Transaction Planning</div>	<div style="background-color: yellow; padding: 2px;">[Digital] Marketing Channels Development</div>	<div style="background-color: yellow; padding: 2px;">[Digital] Content Management</div> <div style="background-color: red; padding: 2px;">Social Media Marketing</div>	<div style="background-color: red; padding: 2px;">Social Media Marketing</div>	<div style="background-color: yellow; padding: 2px;">Customer Relationship Management</div> <div style="background-color: yellow; padding: 2px;">[Digital] Marketing Channels Management</div> <div style="background-color: red; padding: 2px;">Data Management</div>

Figure 5.7 Value Stream and Capability Mapping

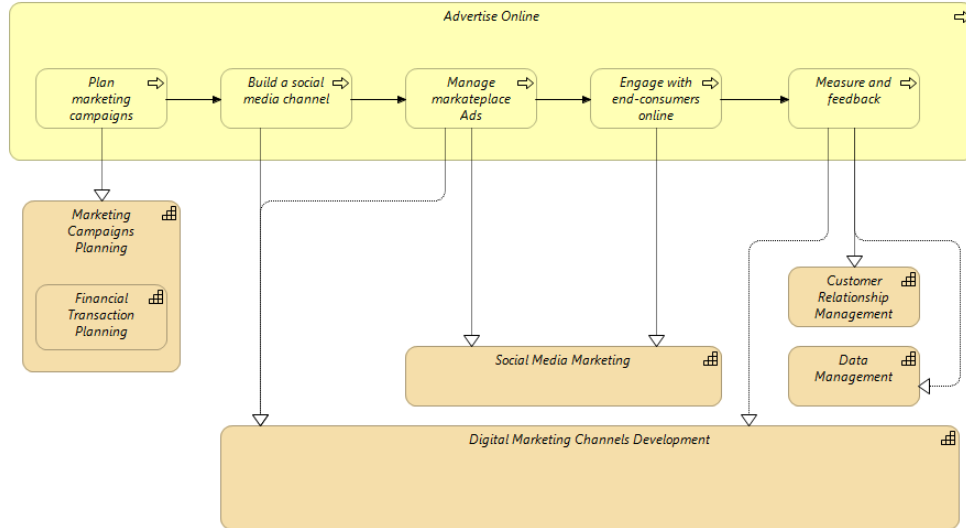

For instance, we *could* use a matrix to map the value stream stage with business capabilities. From this moment on, one should start mapping the business concepts. The value stream decomposition and the value stream’s stage vs. capabilities map are the start point.

Table 5.10 *Merkatos'* Information Reference Catalog

Advertising Online				
Information concepts	Information concepts category	Information concept definition	Information concept types	Related information concepts
Advertisement	Primary	This refers to a non-personal, public communication.	Messages, print ads, announcements, word-of-the-mouth, testimonial	Online Advertisement, Consumer, Customer, Audience, Advertising campaign plan
Online Advertisement	Secondary	This refers to an internet-based public communication.	--/--	Advertisement, Social media subscriber, Advertising campaign plan
Customer	Primary	Refers to an entity, mainly organizations, contracting marketing services.	Retailer, Technical Professionals, Public/Private Institutions.	Advertisement, Consumer, Advertising campaign plan

<i>Consumer</i>	<i>Primary</i>	<i>This refers to a targeted advertisement consumer.</i>	<i>Retailer, individual.</i>	<i>Advertisement</i>
<i>Audience</i>	<i>Secondary</i>	<i>This refers to an end-consumer of the advertisement, and not necessarily a buyer.</i>	<i>Audience, individual, Internet audience or community.</i>	<i>Advertisement, Online advertisement, Social media channel</i>
<i>Media channel</i>	<i>Primary</i>	<i>This refers to a mean used to communicate with target consumers.</i>	<i>Newspapers, magazines, radio, television, billboards, telephone, post, and door to door.</i>	<i>Advertisement, Social media channel, Customer</i>
<i>Social media channel</i>	<i>Secondary</i>	<i>Refers to the internet or mobile phone means used to share and disseminate information.</i>	<i>Networking websites, Blogs, Facebook, Twitter, and others.</i>	<i>Media channel, Advertising campaign, Social media marketing campaign</i>
<i>Advertising campaign</i>	<i>Primary</i>	<i>Refers to a coordinated effort of a company to increase product or service awareness through a series of a single advertisement message.</i>	<i>Product, brand, service, message.</i>	<i>Social media channel, Media channel, Advertising campaign plan, Payment</i>
<i>Social media marketing campaign</i>	<i>Secondary</i>	<i>This refers to an advertising campaign primarily executed through social media channels.</i>	<i>Facebook page, posts.</i>	<i>Advertising campaign, Payment</i>
<i>Social media subscriber</i>	<i>Primary</i>	<i>Refers to individual, consumer subscribing a social media channel.</i>	<i>Individual, community.</i>	<i>Social media channel, Consumer Advertising campaign plan</i>
<i>Digital content</i>	<i>Primary</i>	<i>Refers to any content existing in a format of digital data, either visual or audio related to a brand.</i>	<i>Video record, Audio record, Text, and Graphics.</i>	<i>Audience, Social media subscriber, advertisement</i>
<i>Advertising campaign plan</i>	<i>Primary</i>	<i>Refers to a plan describing the objectives, metrics, content, resources, and activities necessary for the delivery of the advertisement.</i>	<i>Asset, product, brand, employee.</i>	<i>Advertisement, Social media channel, Social media marketing campaign, Payment, Audience</i>

<i>Customer Intimacy rate</i>	<i>Secondary</i>	<i>This refers to a metric of a deeper understanding of consumer's needs as the result of a bidirectional interaction supported by social media channels.</i>	<i>Product, brand, pricing.</i>	<i>Customer, Consumer</i>
<i>Payment</i>	<i>Primary</i>	<i>Refers to a monetary exchange event between businesses (buyer and seller)</i>	<i>Buy, sell, financial transaction</i>	<i>Advertising campaign, Advertising campaign Plan, Advertisement, Online advertisement, Customer, Social media channel</i>
<i>Human resources</i>	<i>Primary</i>	<i>Refers to individuals or peoples required within the advertising plan to execute the planned activities.</i>	<i>Employees, Manager</i>	<i>Advertising campaign plan</i>

Figure 5.9. *Merkatos'* Reference Information Map

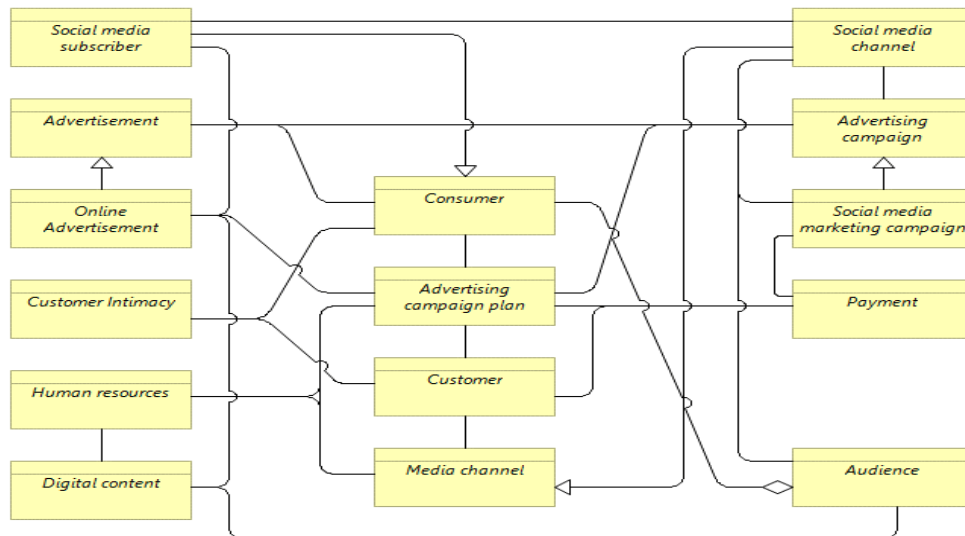

### Deciding on which E-business solutions to deploy

In order to decide on appropriate *e-business applications* to adapt and deploy for the *E-business Architecture* execution, *Merkatos* senior managers will perform the following

analysis. As by the example Table 5.11, they understand how to map their e-business value-adding activities with industry available solutions.

Table 5.11 *Merkatos E-Business Processes vs. E-Business Systems Map*

<b>E-Business Information Entities</b>						
		<b>Plan marketing campaigns</b>	<b>Build a social media channel</b>	<b>Manage the marketplace Ads</b>	<b>Engage with end-consumers online</b>	<b>Measure and feedback</b>
<i>E-Business Systems</i> <sub>1...N</sub>	<b>Planning systems</b>	<i>Ads campaign plan</i>				
	<b>Payment systems</b>	<i>Payment</i>				
	...		<i>Social media channels</i>	<i>Online Ads visibility trends</i>		
	<b>Customer Relationship System</b>				<i>Consumer awareness rate</i>	<i>Customer intimacy rate</i>

5.1.4. WRAPPING MERKATOS E-BUSINESS PROFILE REFERENCE MODELS

We have demonstrated how *Merkatos* accomplished its technology-independent *E-Business Architecture* guided by our  $\int$ -Framework and the supporting tools. In fact, *Merkatos* ultimate milestone is operationalizing the e-business architecture by adopting and deploying related e-business systems.

Nevertheless, our framework's purpose is to ensure that *Merkatos* has a referencing profile guiding the decision-making for changes. By exploiting our framework, *Merkatos* was able to describe the business context, both external (*cf.* Table 5.1) and internal (*cf.* Table 5.2, Table 5.3, Table 5.4) state of affairs, and depict the *E-Business Adoption Motivations* (*cf.* Figure 5.1).

Also, our framework allowed *Merkatos* to depict the relevant digital strategic options (*cf.* Table 5.4, Figure 5.2), and the e-business model (*cf.* Table 5.6, Figure 5.3) to be implemented by *E-business Architecture*.

So, whenever it is required, our framework presents simple, easy to use tools and common techniques. While *Merkatos* senior managers understood how the e-business endeavor could be undertaken, and decided to undergo the implementation stage by using our framework,

enabled them to translate the business model onto value-adding activities – value streams (cf. Table 5.7, Table 5.8), before devising any model or diagram.

Also, *Merkatos* was able to couple the value streams with additional descriptions such as the supporting capabilities (cf. Table 5.9), and the related business information concepts (cf. Table. 5.10).

The tabular descriptions on *Merkatos E-business* activities boosted a good understanding on how they will undertake their digital value delivery, and acted as a support for better understanding of related diagrammatic models (cf. Figure 5.4, Figure 5.5, Figure 5.6), while the *E-Business Architecture Reference* artifacts of *Merkatos' Profile* using ArchiMate language was delivered.

As *Merkatos E-Business Profile* is compiled, and contains the artifacts resulting from the e-readiness analysis to the implementation descriptions based on the *Merkatos* Industry and business context state of affairs, the senior managers feel confident on the next stage challenges – *selecting the e-business applications to adapt and deploy*. *Merkatos* senior managers understand that the e-business architecture in their profile will guide the decisions to deploy industry solutions.

## **Chapter 6. EVALUATION**

## SYNOPSIS

In this chapter, we proceed with the evaluation of our proposed framework based on its application demonstrated in the former section 5.1 and the resulting artifacts. We adopt an ex-post evaluation strategy [38] to analyze how our framework could support the design and implementation of a manageable *SME's* e-business in line with the criteria by Putra & Hasibuan [3], in the context of design science paradigm.

### 6.1. COMPARATIVE ANALYSIS OF J-FRAMEWORK VS. BASELINE FRAMEWORK

Although Putra & Hasibuan's work [3] is related to research and evaluation of *SMEs'* e-business adoption behavior per se, we found the work envisioning how *SMEs* e-business should be designed, implemented, and assessed later. Hence, as we have adapted their proposed model as our baseline framework for *SMEs'* e-business development purposes, we will analyze how our framework could support the development of *SMEs'* e-business standing the future evaluation of *SMEs' e-business* adoption behavior.

In the following Table 6.1, we compared our proposal and highlighted the most relevant proprieties that contribute to the knowledge base. Remarkably, our proposal presents significant artifacts, and it is compatible with other frameworks related to analysis, and modeling of businesses in general, and e-business.

Our proposal fulfills the recommended criteria, and the solution objectives defined in subsection 1.4.2. Our framework showed how management and *EA* practices are integrated to support the design of a manageable *SMEs'* e-business, and how a technology-adaptive e-business design could be handled. Moreover, our framework is more descriptive than the baseline framework and provides more details on most aspects related to e-business adoption.

Our proposal places the technology and e-business application selection at a lower level, and we propose an additional facet – *the deployment facet*. The *SMEs* engaging in deployment facet establish relationships with solutions vendors, and other organizations that support their value propositions delivery.

Table 6.1. Comparative Analysis of the J-Framework vs. Baseline Framework

FRAMEWORK CRITERIA	BASELINE BUILDING BLOCKS	J-FRAMEWORK BUILDING BLOCKS	REMARKS
<p><b>SMEs context analysis:</b></p> <ul style="list-style-type: none"> <li>- The baseline work suggests an analysis in the context of people, organizations, technology, theories, and methodologies.</li> </ul>	<p><b>Critical adoption factors</b></p>	<p><b>Critical adoption factors:</b></p> <ul style="list-style-type: none"> <li>- Sociocultural</li> <li>- Technological</li> <li>- Economical</li> <li>- Political &amp; legal</li> </ul>	<ul style="list-style-type: none"> <li>- Our proposal introduces a methodology – STEP Analysis – common to the management area to analyze the key digital business elements: people, organizations, information, and technology.</li> <li>- Our proposal presents artifacts as tools to perform context analysis (cf. Table 4.1, Table 4.2) and to model the analysis with a reference modeling language (cf. Figure 4.3).</li> </ul>
<p><b>SMEs digital readiness analysis:</b></p> <ul style="list-style-type: none"> <li>- The baseline work recommends a fine-grained readiness analysis of SMEs, ensured by SME's profiling approach. Also, the research recommends that SME's Profiles and CAFs are mutually related.</li> </ul>	<p><b>Readiness:</b></p> <ul style="list-style-type: none"> <li>- SME Profile</li> </ul>	<p><b>E-Readiness:</b></p> <ul style="list-style-type: none"> <li>- SME digital strategy</li> <li>- SME digital value drivers</li> <li>- SME digital business model</li> </ul>	<ul style="list-style-type: none"> <li>- Our proposal presents a mechanism to relate CAFs to the SMEs profile through the context's digital key elements. However, we present a different SME profiling approach, which is extended to the implementation facet; here, we posit technologies and e-business applications are adopted at the <b>deployment facet</b>.</li> <li>- Our framework introduces the digital strategy component into the readiness profiling block, which instantiates the environment key digital elements to shape an SME's digital transformation within the industry.</li> <li>- Our proposal relates the CAFs of external context with its internal readiness aspects through a managerial framework – SWOT Analysis. Our proposal presents artifacts that support (e-)readiness analysis (cf. Table 4.4, Table 4.5, Table 4.6).</li> <li>- Also, we include relevant components for readiness evaluations, such as business model and digital value drivers' catalog (cf. Table 4.7, Table 4.8). Additionally, our proposal presents tools for its modeling (cf. Table 4.9, Figure 4.4, Table 4.10, Figure 4.5).</li> </ul>
<p><b>SMEs e-business implementation analysis:</b></p> <ul style="list-style-type: none"> <li>- Baseline work recommends a non-sequential approach</li> </ul>	<p><b>Implementation:</b></p> <ul style="list-style-type: none"> <li>- SME value chain</li> <li>- E-Business capabilities</li> </ul>	<p><b>E-Implementation:</b></p> <ul style="list-style-type: none"> <li>- SME e-business value streams</li> <li>- SME e-business capabilities</li> <li>- SME e-business processes</li> </ul>	<ul style="list-style-type: none"> <li>- Our proposal presents a fine-grained approach for SMEs' e-business implementation. We offer an adaptive approach to implement e-business through end-to-end value-adding SMEs' activities.</li> <li>- Our framework presents a manageable approach for e-business adoption, e-business applications selection, and deployment.</li> </ul>

*that enables SMEs to start adopting e-business based on any e-business capability that suits their business objectives and subsequently chooses an e-business application that can bring in the capability to the adopting SME.*

- *E-Business applications*

- *SME e-business information structure*

- *Our proposal is compatible with techniques that support the design of a manageable e-business architecture. And a methodology that supports the modeling process in the context of design science (cf. Figure 4.6, Table 2.1, Table 2.2, Table 2.3, Table 2.3, Table 4.11, Table 4.12, Table 4.13).*

- *Moreover, our proposal presents an approach that supports SMEs' e-business interoperability at a high-level perspective, such as the value chain perspective. {Bibliography}*

## 6.2. ANALYZING J-FRAMEWORK OVER *MERKATOS* PROFILE REFERENCE MODELS

In the former analysis, we evaluate our proposal against prior criteria found in the reference work, herein we analysis our proposal over the create artifacts also regarding former reported *SME* limitation in the baseline research [3][30]. We recall these limitations in summary as – “inadequate provision of practical tools for *SMEs* in decision-making and implementations,” described as:

- Lack of an established set of critical adoption factors of e-business for *SME* serving as the source of indicators in signaling the readiness of *SMEs* to adopt e-business.
- Trivial adoption of e-business applications regardless of *SMEs* profile based on an assessment of their capacity to adopt a specific e-business application or readiness to adopt e-business.
- Need for a well-designed implementation model that is adaptive to technology and receptive to the nature of *SME*, serving as a roadmap towards the transformation of *SMEs*.

### 6.2.1. WHAT HAS BECOME POSSIBLE AS BY *MERKATOS* E-BUSINESS PROFILING

Reviewing section 5.1, one could find how those limitations where overcome in the case of the *Merkatos E-business* Initiative. We recognize that having an established set of drivers and hinders from *SME*, for instance, operating in the US Market, could be a misleading reference for an *SME* e-business adoption initiative in Mozambique. However, possessing practical tools and a common methodology guiding the assessment of the diverse industry and business context *CAFs* became the pragmatic approach.

So now, *Merkatos*, like any other *SME* in any industry and business context, can identify the relevant e-business adoption factors (drivers/hinders) (*cf.* Table 5.1, Figure 5.1) based on common digital key elements, of any time of business lifecycle.

Also, *Merkatos* readiness profiling based strategic vision on the relevant digital hotspot of its industry and business context demonstrated the feasibility of our proposal (*cf.* Table 5.4, Figure 5.2, Table 5.5, Table 5.6, Figure 5.3). *Merkatos* has been prevented from trivially adopting any existing technology/e-business applications before they had understood their motivation, and both technical and financial capabilities, regardless they ICT maturity level. Additionally, by approaching a well-structured implementation paradigm – *E-Business*

*Architecture* (cf. section 4.4), *Merkatos* was able to roadmapping a technology-independent e-business adoption models (cf. section 5.1.3). Moreover, our proposal is supported by simple matrices and techniques for implementation stage analysis and description, considering management personnel competences limitation on EA architecture tools, although the proposed tabular tools are EA architecture tools compatible aiming EA architecture support.

#### 6.2.2. SUMMARY OF OUR PROPOSED SOLUTION FRAMEWORK ACHIEVEMENTS.

Summarizing our study, in short words, we have achieved our objective, **providing a framework that supports the development of SMEs e-business in diverse business contexts and industries by integrating managerial and EA practices**. This achievement is fundamentally sustained by 1) identification of knowledge base conceptual models regarding *e-business reference modeling and adoption pattern* from ex-ante work; 2) analyzing the adaptability of baseline conceptual models to suit the generic managerial frameworks and EA practice components; and by 3) development of the framework proposal and tools, and demonstration of its application through a case study.

Moreover, our study complies with the adopted research methodology on design research science. Nevertheless, further reach work could be undertaken as we state in the following section 7.3.

## **Chapter 7. CONCLUSION**

## SYNOPSIS

In this chapter, we present our conclusions of this study, and we summarize the present work contributions for academia and practice, the channels for communication of the results, and future work.

### 7.1. CONTRIBUTION

In this work, we exhaustively demonstrated how to approach e-business adoption through *EA* reference modeling. Also, we have evaluated the utility of the proposed design solution against *leading criteria* proposed by Putra & Hasibuan [3]. And we conclude that this baseline framework is suitable to couple managerial techniques and *BA* techniques to support the design of e-business for *SMEs*. Moreover, integrating the two disciplines to build an e-business framework contribute to an enhanced decision-making for e-business adoption process. Henceforth, the main contributions of the work are:

- **Scholars** have a detailed, well-designed, and technology-independent reference modeling approach to support the *SMEs*' e-business adoption pattern description. Also, the descriptive models become understandable by management personnel in decision-making for e-business adoption. Through extended common managerial analysis tools for critical adoption factors, facets become possible to identify an *SME*'s specific drivers and hinders related to industry or context transversal digital elements (people, business, information, and technology).

From the readiness perspective, *SMEs*' readiness profiles are explicitly related to context adoptions factors guiding the depiction of *SME change motivations and business model innovations*. And industry or context drivers are cataloged for *SMEs* e-business adoption referencing purpose.

Moreover, a fine-grained e-business architecture approach through *SMEs value-adding activities* is demonstrated, independently of e-business solutions being deployed at any stage of the business lifecycle.

- **Practitioners** engaging in e-business implementation have an instrument to apply their competencies on situational analysis to depict digital business value drivers, and digital strategy and e-business models. Also, it allows them to boost the understanding of how digital service and technologies are deployed to realize

business goals. Moreover, they are benefited from a new approach to handle *SMEs'* e-business architecture analysis and modeling, which is *EA* architecture tools compatible.

## 7.2. COMMUNICATION

This work was developed as a pre-requisite to a *master's degree in Information and Enterprise Systems*. Nevertheless, we have elaborated related paper and submitted it at 22nd International Conference on Enterprise Information Systems (ICEIS) 2020. Thereafter, a final revision with further refinements of the proposal will be published and openly accessible either entirely or in parts.

## 7.3. FUTURE WORK

Following the work, further research work is required. Still, there are opportunities to test our proposal in a real business environment; also, as we posited, remains the deployment perspective to be developed and coupled with the rest of the building blocks.

## REFERENCES

- [1] R. Baxter, N. Hastings, A. Law, and E. J. . Glass, *Information and Communications for Development 2018: Data-Driven Development*, vol. 39, no. 5. The World Bank, 2018.
- [2] D. Kayisire and J. Wei, “ICT Adoption and Usage in Africa: Towards an Efficiency Assessment,” *Inf. Technol. Dev.*, vol. 22, no. 4, pp. 630–653, 2016.
- [3] P. O. H. Putra and Z. A. Hasibuan, “E-business framework for small and medium enterprises: A critical review,” *2015 3rd Int. Conf. Inf. Commun. Technol. ICoICT 2015*, pp. 516–521, 2015.
- [4] J. Hoogervorst, “A framework for enterprise engineering,” *Int. J. Internet Enterp. Manag.*, vol. 7, no. 1, p. 5, 2011.
- [5] J. A. P. Hoogervorst, *Foundations of Enterprise Governance and Enterprise Engineering*. Cham: Springer International Publishing, 2017.
- [6] F. J. Armour, S. H. Kaisler, and S. Y. Liu, “Building an Enterprise Architecture Step by Step,” *IT Prof.*, vol. 1, no. 4, pp. 31–39, 1999.
- [7] K. Peffers, T. Tuunanen, M. A. Rothenberger, and S. Chatterjee, “A Design Science Research Methodology for Information Systems Research,” *J. Manag. Inf. Syst.*, vol. 24, no. 3, pp. 45–77, Dec. 2007.
- [8] B. Kuechler and S. Petter, *Design Science Research in Information Systems: Advances in Theory and Practice*, vol. 7286. Berlin, Heidelberg: Springer Berlin Heidelberg, 2012.
- [9] J. Venable, J. Pries-heje, and R. Baskerville, “A Comprehensive Framework for Evaluation in Design Science Research,” pp. 423–438, 2012.
- [10] The Open Group, *The TOGAF® Standard, Version 9.2*. The Open Group, 2018.
- [11] M. Lankhorst, *Enterprise Architecture at Work*. Berlin, Heidelberg: Springer Berlin Heidelberg, 2017.
- [12] M. O. Land, E. Proper, M. Waage, J. Cloo, and C. Steghuis, *Enterprise Architecture Creating Value by Informed Governance*. 2009.
- [13] J. A. P. Hoogervorst, “Enterprise Architecture: Enabling integration, agility and change,” *Int. J. Coop. Inf. Syst.*, vol. 13, no. 03, pp. 213–233, Sep. 2004.
- [14] P. Fettke and P. Loos, *Reference Modeling for Business Systems Analysis*. IGI Global, 2006.

- [15] The Open Group, “ArchiMate® 3.0.1 Specification,” in *Open Group Standard*, The Open Group, 2017.
- [16] L. O. Meertens, M. E. Iacob, L. J. M. Nieuwenhuis, M. J. van Sinderen, H. Jonkers, and D. Quartel, “Mapping the business model canvas to ArchiMate,” *Proc. 27th Annu. ACM Symp. Appl. Comput. - SAC '12*, p. 1694, 2012.
- [17] M. A. Macedo, A. Guillermo, R. Lezana, N. C. Filho, M. Gizelli, and D. Camillo, “Bussines Model Canvas : a construção do modelo de negócio de uma empresa de móveis,” 2013.
- [18] M. E. Iacob, L. O. Meertens, H. Jonkers, D. A. C. Quartel, L. J. M. Nieuwenhuis, and M. J. van Sinderen, “From enterprise architecture to business models and back,” *Softw. Syst. Model.*, vol. 13, no. 3, pp. 1059–1083, 2014.
- [19] A. Osterwalder and Y. Pigneur, “An e-business model ontology for modeling e-business,” *Proceeding 15th Bled Electron. Commer. Conf.*, p. 12, 2002.
- [20] B. G. Wierda, *Mastering ArchiMate*. R&A, 2014.
- [21] The Open Group, “Open Business Architecture ( O-BA ) – Part I,” Reading, Berkshire, United Kingdom, P161, 2016.
- [22] S. DuPont *et al.*, “TOGAF ® Series Guide Business Models,” *TOGAF ® Ser. Guid.*, p. 27, 2018.
- [23] R. Bi, R. M. Davison, and K. X. Smyrnios, “E-Business use and value for fast growth small-to-medium enterprises in turbulent environment,” *PACIS 2014 Proc.*, 2014.
- [24] T. Blevins and M. Lambert, “TOGAF ® Series Guide Business Capabilities,” *TOGAF ® Ser. Guid.*, 2018.
- [25] A. Sanchez, R. Basanya, T. Janowski, and A. Ojo, “Enterprise Architectures – Enabling Interoperability Between Organizations,” no. i, pp. 1–4, 2015.
- [26] The Open Group, “TOGAF ® Series Guide Value Streams,” *TOGAF ® Ser. Guid.*, 2017.
- [27] A. S. Dupont, J. B. Lail, and S. Marshall, “TOGAF ® Series Guide Information Mapping.” The Open Group, 2019.
- [28] IEEE, “Systems and software engineering — Architecture description,” *Funct. Anal. Its Appl.*, vol. 46, no. 4, 2011.
- [29] O. Noran, “Using reference models in enterprise architecture: An example,” *Ref.*

- Model. Bus. Syst. Anal.*, no. December, pp. 141–165, 2006.
- [30] T. Sammut-Bonnici and D. Galea, “Pest Analysis,” *Encyclopedia of Management*. Wiley, pp. 567–619, 2014.
- [31] V. B. Mišić and J. L. Zhao, “E-Business Reference Models,” in *Electronic Business, Volume 1*, I. Lee, Ed. IGI Global, 2009, pp. 325–346.
- [32] R. Casadesus-Masanell and J. E. Ricart, “From strategy to business models and onto tactics,” *Long Range Plann.*, vol. 43, no. 2–3, pp. 195–215, 2010.
- [33] M. Cigaina and U. Riss, “Digital Business Modeling,” *SAP White Paper Digital Transformation*, no. May. pp. 0–59, 2017.
- [34] MITSLOAN, “Top 10 Lessons on Strategy,” *SLOANSELECT COLLECTION*. MIT SLOAN MANAGEMENT REVIEW, pp. 22–27, 2015.
- [35] D. Chaffey, *Digital business and E-commerce management: strategy, implementation and practice*, 6th ed. Pearson Education, 2015.
- [36] M. Payne, “REINVENTING THE RINGS,” *Bus. Strateg. Rev.*, vol. 23, no. 1, pp. 75–81, Mar. 2012.
- [37] APQC, “RETAIL PROCESS CLASSIFICATION FRAMEWORK,” no. v7.2.1. APQC, 2019.
- [38] J. Venable, J. Pries-heje, and R. Baskerville, “FEDS : a Framework for Evaluation in Design Science Research,” no. October 2012, pp. 1–13, 2014.
- [39] M. E. Porter, “Strategy and the Internet,” Boston, MA: Harvard Business Review, 2001, pp. 62–78.

## **APPENDIX**

**A: PROMINENT APPLICATIONS OF THE INTERNET IN THE VALUE CHAIN**

<p><b>Firm Infrastructure</b></p> <ul style="list-style-type: none"> <li>• Web-based, distributed financial and ERP systems</li> <li>• On-line investor relations (e.g., information dissemination, broadcast conference calls)</li> </ul>				
<p><b>Human Resource Management</b></p> <ul style="list-style-type: none"> <li>• Self-service personnel and benefits administration</li> <li>• Web-based training</li> <li>• Internet-based sharing and dissemination of company information</li> <li>• Electronic time and expense reporting</li> </ul>				
<p><b>Technology Development</b></p> <ul style="list-style-type: none"> <li>• Collaborative product design across locations and among multiple value-system participants</li> <li>• Knowledge directories accessible from all parts of the organization</li> <li>• Real-time access by R&amp;D to on-line sales and service information</li> </ul>				
<p><b>Procurement</b></p> <ul style="list-style-type: none"> <li>• Internet-enabled demand planning and fulfillment</li> <li>• Other linkage of purchase, inventory, and forecasting systems with suppliers</li> <li>• Automated "requisition to pay"</li> <li>• Direct and indirect procurement via marketplaces, exchanges, auctions, and buyer-seller matching</li> </ul>				
<p><b>Inbound Logistics</b></p> <ul style="list-style-type: none"> <li>• Real-time integrated scheduling, shipping, warehouse management, demand management and planning, and advanced planning and scheduling across the company and its suppliers</li> <li>• Dissemination throughout the company of real-time Inbound and progress Inventory data</li> </ul>	<p><b>Operations</b></p> <ul style="list-style-type: none"> <li>• Integrated information exchange, scheduling, and decision making in tri-house plants, contract assemblers, and components suppliers</li> <li>• Real-time available to promise and capable-to-promise information available to the sales force and channels</li> </ul>	<p><b>Outbound Logistics</b></p> <ul style="list-style-type: none"> <li>• Real-time transaction of orders whether initiated by an end consumer, a salesperson, or a channel partner</li> <li>• Automated customer specific agreements and contract terms</li> <li>• Customer and channel access to product development and delivery status</li> <li>• Collaborative integration with customer forecasting systems</li> <li>• Integrated channel management including information exchanger, warranty claims, and contract management (versioning; process control)</li> </ul>	<p><b>Marketing and Sales</b></p> <ul style="list-style-type: none"> <li>• On-line sales channels including Web sites and marketplaces</li> <li>• Real-time inside and outside access to customer information, product catalogs, dynamic pricing, inventory availability on-line submission of quotes, and order entry</li> <li>• On-line product configurators</li> <li>• Customer-tailored marketing via customer profiling</li> <li>• Push advertising</li> <li>• Tailored on-line access</li> <li>• Real-time customer feedback through Web survey, opt-in/opt-out marketing and promotion response tracking</li> </ul>	<p><b>After-Sales Service</b></p> <ul style="list-style-type: none"> <li>• On-line support of customer service representatives through e-mail response management, biffing integration, co-browse, chat, "call me now," voice-over-IP, and other uses of video streaming</li> <li>• Customer self-service via Web Sites and intelligent service request processing including updates to billing and shipping profiles</li> <li>• Real-time field service access to customer account review, schematic review, parts availability and ordering, work-order update, and service parts management</li> </ul>

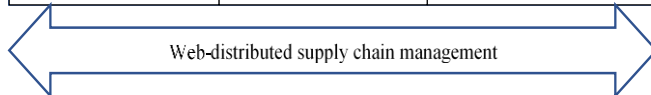

Source: Michael E. Porter [39]

---

<sup>i</sup> **Stakeholders** refer to consumers, employees, advisors, *SME owner's* family members, community, etc.

<sup>ii</sup> **Organizations** refer to clients, suppliers, competitors, partners, service providers, etc.

<sup>iii</sup> VP=value proposition; CSs=customer segments; KP=key partnerships; CS=cost structure; RS=revenue streams; KR=key resources; CN=channels; CR=customer relationships; KA=key activities

<sup>iv</sup> Source: <https://www.imf.org/en/countries/moz>, visited 2019/03/01