

# Modules from the BIP FOOD INNOVATION AND THE CONSUMER

Editors: Ana Pinto de Moura  
Luís Miguel Cunha  
Purificación García Segovia

## FOOD INNOVATION AND THE CONSUMER

.....

**BLENDED INTENSIVE PROGRAM | ONLINE: 10 - 31 March 2025 | FACE-TO-FACE: 4 - 11 April 2025**

PARTNERS:

# 4.2 New food technologies for food safety

Vasilis Valdramidis

## FOOD INNOVATION AND THE CONSUMER

.....

**BLENDED INTENSIVE PROGRAM | ONLINE: 10 - 31 March 2025 | FACE-TO-FACE: 7 - 11 April 2025**

PARTNERS:

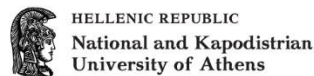

# Food technologies for food safety

Traditional technologies  
+  
Novel/ emerging or alternative technologies

- Pasteurisation
- Vacuum packaging
- Ohmic heating (for pasteurisation)
- Microwaves/Dielectric heating
- UV light
- Irradiation
- High Hydrostatic Pressure (HHP)
- Pulsed Electric Field (PEF)
- Ultrasound (US)
- Hydrodynamic cavitation (HC)
- High Pressure CO<sub>2</sub>
- Cold atmospheric plasma (CAP)

Other technologies

- Osmotic dehydration
- Chemical and Biochemical techniques
  - Organic acids
  - Ozone
  - Plant derived antimicrobials

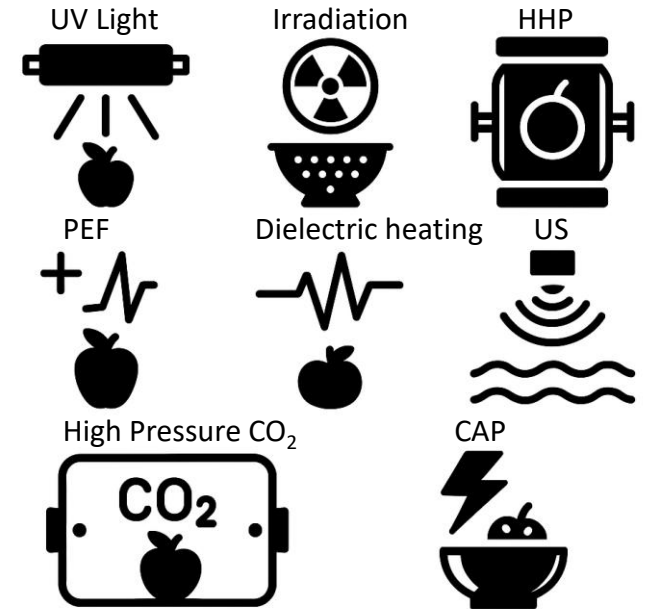

# Technology drivers



## Regulation

-FDA (Food and Drug Administration) 5 log reduction in the number of more resistant pathogens  
- EU Commission Novel Foods Regulation (89/107/EEC) Microbiological criteria for foodstuffs (No 2073/2005, No 1441/2007)



## Shelf-life extension



## Nutritional and Sensory Aspects



## Novel Functional and organoleptic properties

*Enzyme stability, protein-polysaccharide interactions, gelatinization, foaming ...*



## Consumer acceptability

*Minimal processed, requiring minimal preparation*



## Environmental impact

*Energy efficiency, reduction of non-renewable resources*

# Food technologies for food safety

- **Categories Based on Type of Energy or Physical Force:**
- **Pressure-based technologies:**
  - High Hydrostatic Pressure (HHP)
- **Electrical-based technologies:**
  - Pulsed Electric Field (PEF), Cold Atmospheric Plasma (CAP)
- **Acoustic-based technologies:**
  - Ultrasound (US), Hydrodynamic Cavitation (HC)

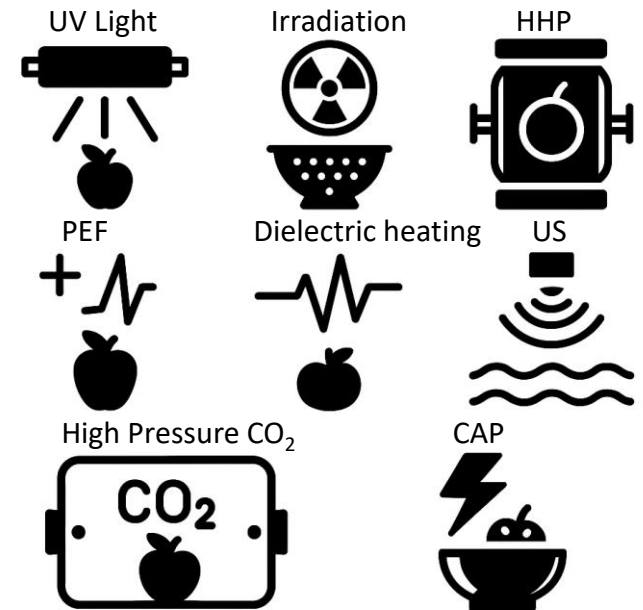

# Food technologies for food safety

- **Categories Based on Type of Energy or Physical Force:**
- **Pressure-based technologies:**
  - High Hydrostatic Pressure (HHP)
    - Definitions & basic principles
    - Antimicrobial mechanism of action
    - Research evaluations
    - Industrial applications and research evaluations
    - Advantages/disadvantages

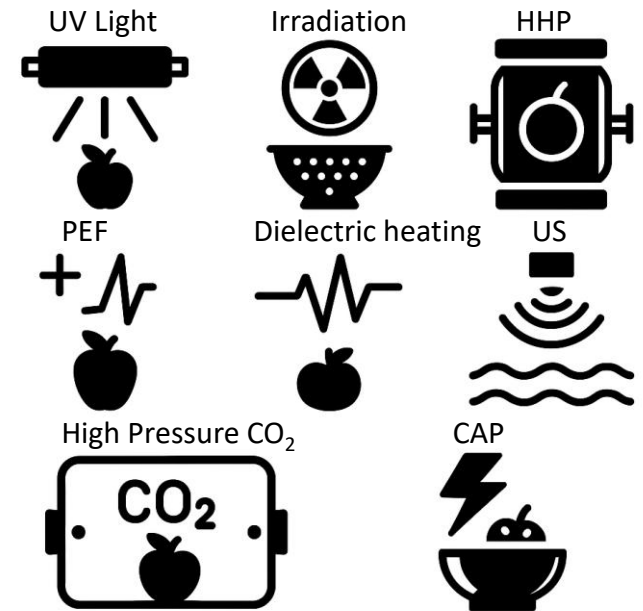

# High Hydrostatic Pressure



## Definitions & basic principles

- **High Pressure Processing (HPP)** is a nonthermal food preservation technique that uses hydrostatic pressure (up to 600 MPa/6000 bar) on **prepacked products**. Vegetative microorganisms are inactivated to ensure food safety and to **extend shelf-life** under refrigeration

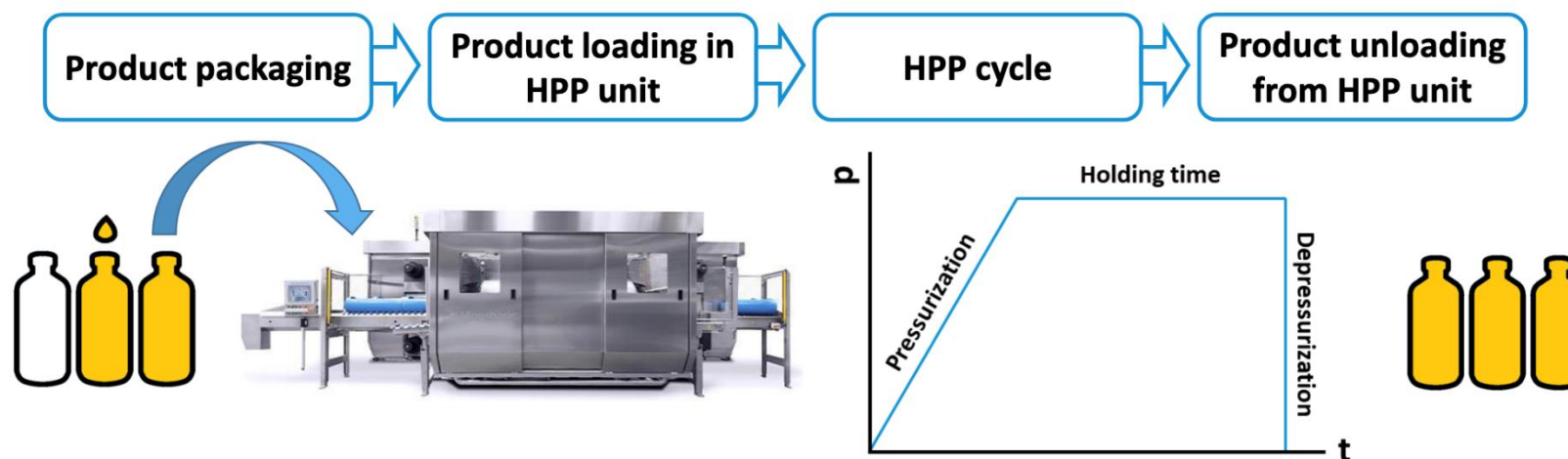

# High Hydrostatic Pressure

## Definitions & basic principles

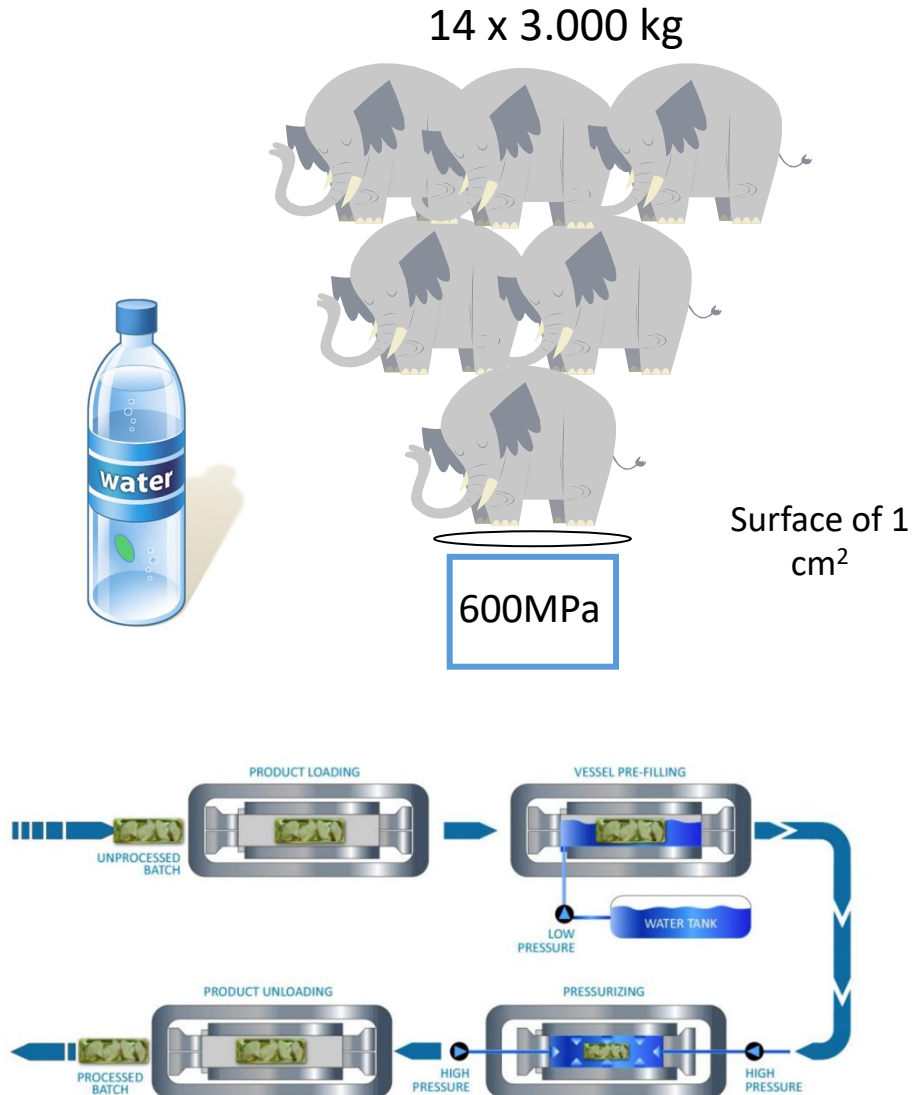

## Basic principles

- Le Chatelier: Application of pressure to a system in equilibrium will favour a reduction in volume to minimize the effect of pressure. Changes in chemical reaction, molecular configuration, phase etc. are enhanced by pressure
- Iso-static: pressure is transmitted in a uniform and instantaneous manner

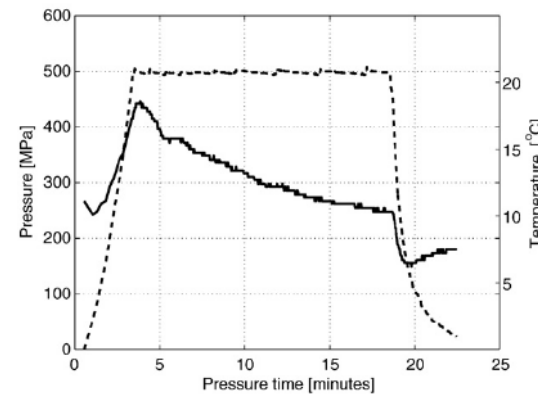

## Parameters

- Pressure (MPa)
- Time (min)
- Product properties
- Temperature (°C)

# High Hydrostatic Pressure

## Definitions & basic principles

High Pressure Pasteurization (HPP)	Pressure assisted thermal sterilization (PATS)	HP modifications	Hyperbaric Storage
<b>400-700 MPa</b> <b>Ambient temperature</b>	<b>600-1000 MPa</b> <b>90-120°C</b>	<b>200-800 MPa</b> <b>25-60°C</b>	<b>25-100 MPa</b> <b>Ambient temperature</b>
<ul style="list-style-type: none"> <li>✓ Shelf-life extension</li> <li>✓ Fresh like (natural) sensory characteristics</li> <li>✓ Higher quality</li> <li>✓ New product development</li> </ul>	<ul style="list-style-type: none"> <li>✓ Sterilization</li> <li>✓ Bacterial spores inactivation</li> </ul>	<ul style="list-style-type: none"> <li>✓ New product development (structures)</li> <li>✓ Tailored processing</li> <li>✓ Functionality (gel formation, bioactivity)</li> </ul>	<ul style="list-style-type: none"> <li>✓ Reduction of naturally spoilage/pathogenic microbiota</li> <li>✓ Reduction of enzymatic activity</li> </ul>
Refrigerated & chilled products	Chilled-shelf stable products	New, functional products	Extended shelf-life

# High Hydrostatic Pressure

## Antimicrobial mechanism of action

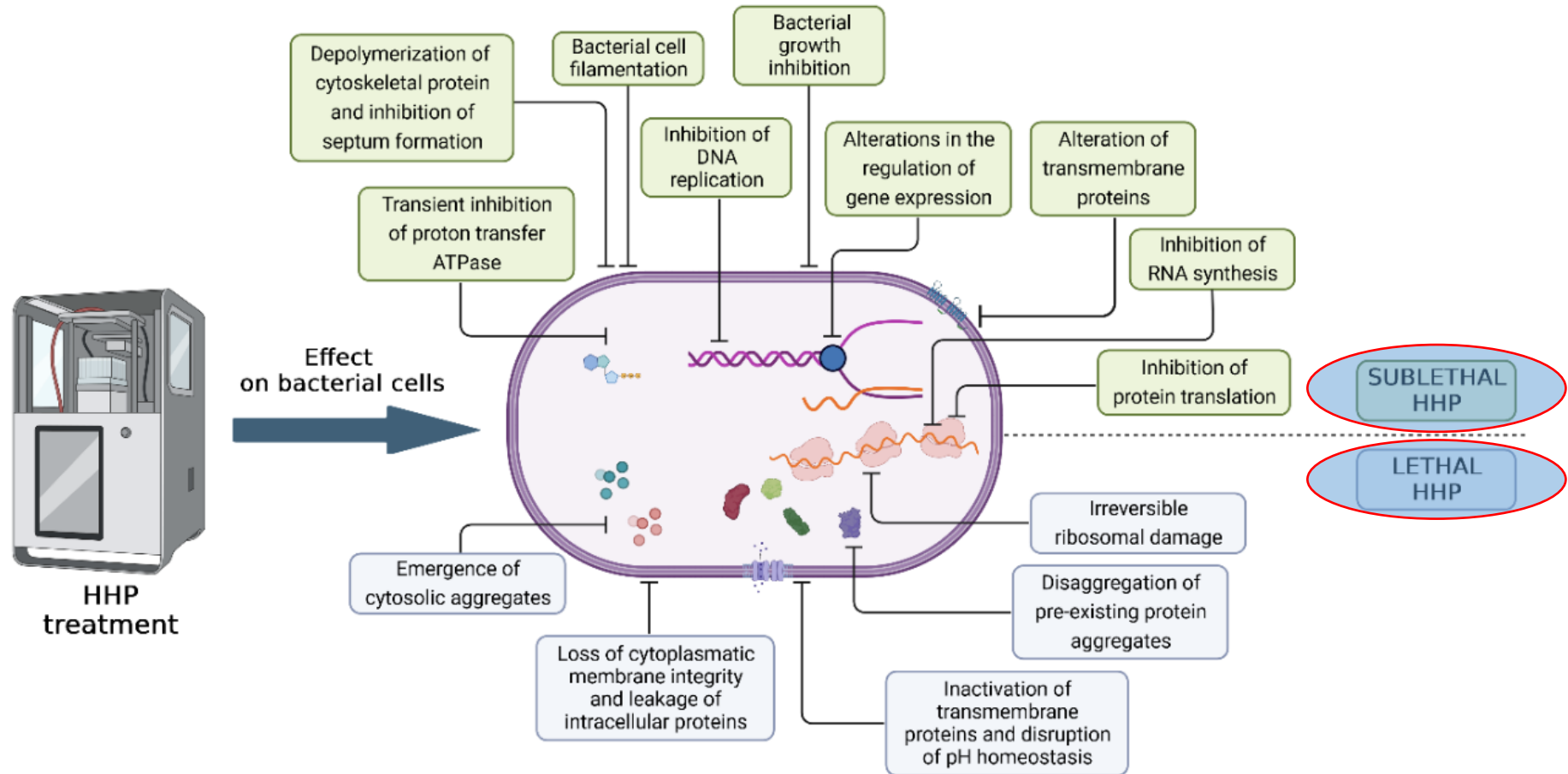

Damage to bacterial cells under the influence of high hydrostatic pressure (<https://doi.org/10.3390/foods13162519>)

# High Hydrostatic Pressure

Antimicrobial mechanism of action (cell membrane modifications)

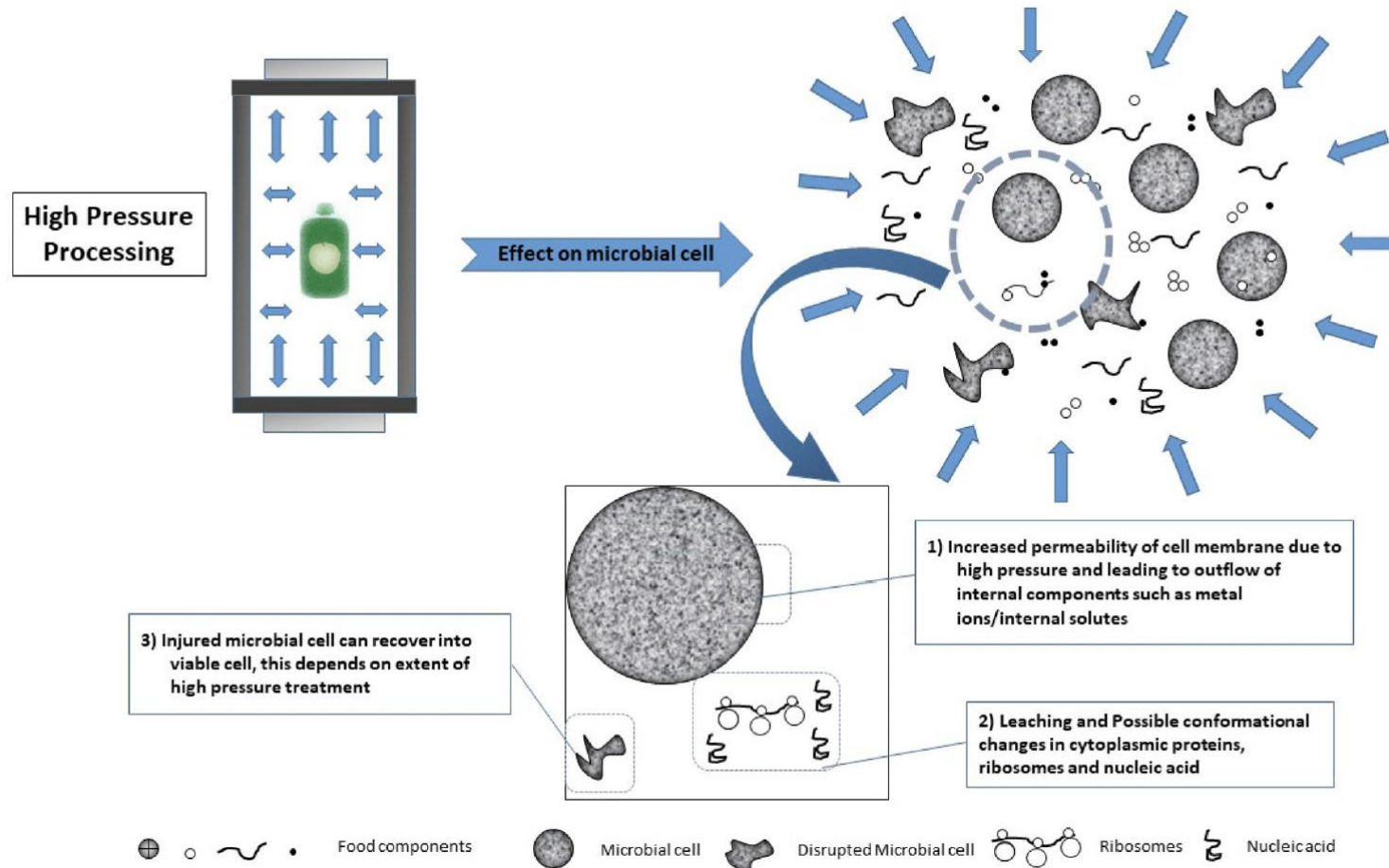

Schematic diagram representing cell membrane modification on high pressure processing (<https://doi.org/10.1007/s10068-020-00831-6>)

# High Hydrostatic Pressure

## Research evaluations

### Case study 1 : Reduction of salt preservatives in meat products

- Preservatives
  - Salt 3.8 g salt/d, EU: 8-11 g
  - Nitrites (EC: 50-150 mg/kg)
  - Nitrosamines
- Food safety
  - Control of *Listeria monocytogenes*
    - EC No 2073/2005, No 1441/2007
    - **< 100 CFU/g** of *L. monocytogenes* for RTE
- Potential Measures
  - Salt replacers
    - Potassium chloride (KCl)
    - Potassium lactate (KC<sub>3</sub>H<sub>5</sub>O<sub>3</sub>)
    - Magnesium sulphate (MgSO<sub>4</sub>)
  - Salt enhancers
    - amino acids, monosodium glutamate (MSG), lactates, yeast products, and other flavorings
  - Physical modifying sodium chloride

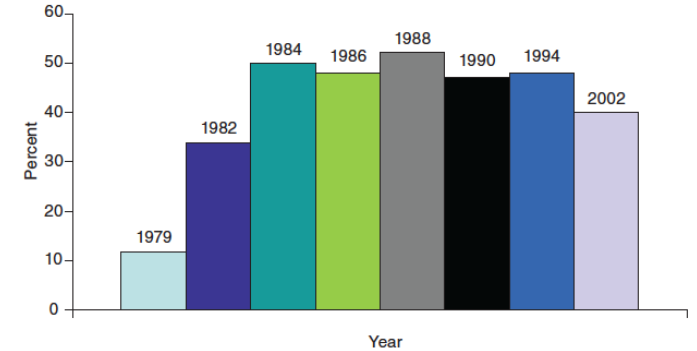

Consumer awareness of the relationship between salt/sodium intake and high blood pressure, 1979–2002. (Henney et al., 2010)

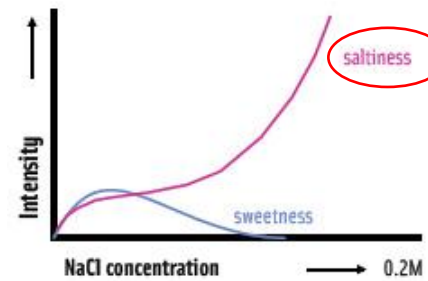

Sodium chloride saltiness

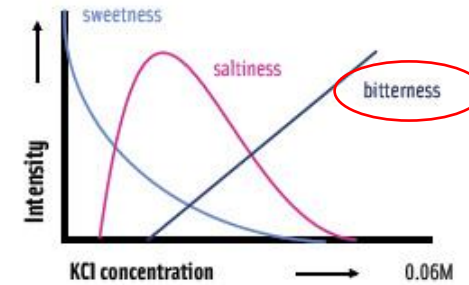

Potassium chloride saltiness

<http://dx.doi.org/10.1016/j.foodcont.2014.07.022>

# High Hydrostatic Pressure

Research evaluations

## Case study 1 : Reduction of salt preservatives in meat products

- Potential solution

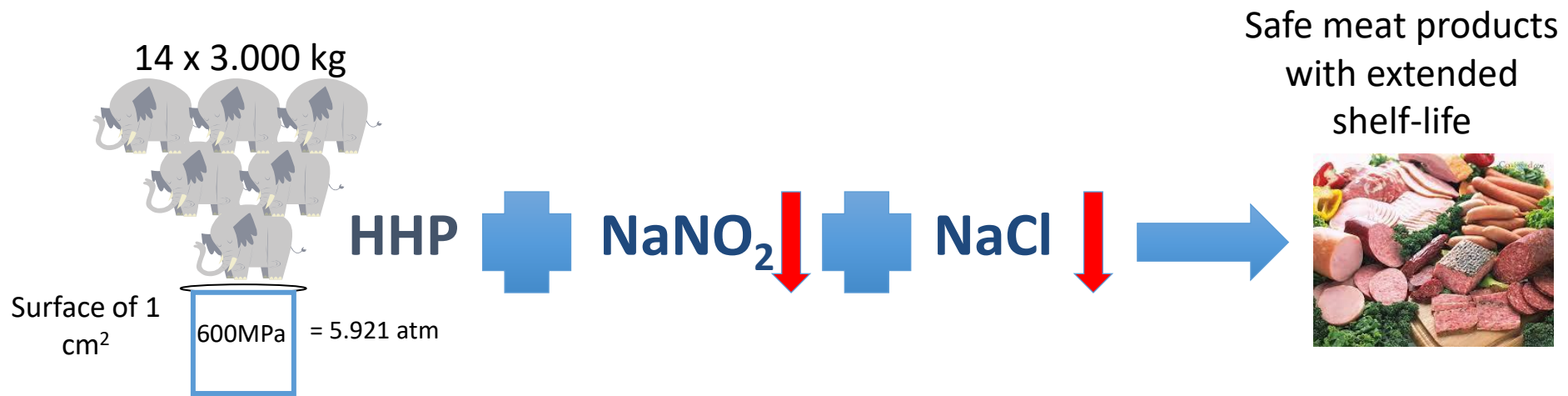

# High Hydrostatic Pressure

Research evaluations

## Case study 1 : Reduction of salt preservatives in meat products

Storage days	0	7	14	21	18	0	7	14	21	28
600 MPa 17.5g/L salt 75mg/L nitrite	-	-	-	-	-	700 MPa 0.09g/L salt 75mg/L nitrite	-	-	-	-
800 MPa 17.5g/L salt 75mg/L nitrite	+	-	-	-	-	700 MPa 11.7g/L salt 0.09g/L nitrite	-	-	-	-
700 MPa 34.9g/L salt 75mg/L nitrite	-	+	+	+	+	700 MPa 29g/L salt 0.09g/L nitrite	-	-	-	-
700 MPa 23.3g/L salt 150mg/L nitrite	-	-	-	-	-	500 MPa 34.9g/L salt 75mg/L nitrite	+	+	-	-
400 MPa 17.5g/L salt 75mg/L nitrite	+	+	+	+	+	700 MPa 23.3g/L salt 150mg/L nitrite	-	-	-	-
500 MPa 0.09g/L salt 75mg/L nitrite	+	+	+	+	+	700 MPa 5.9g/L salt 150mg/L nitrite	-	-	-	-
700 MPa 11.7g/L salt 0.09g/L nitrite	-	-	-	-	-	Responses of <i>Listeria monocytogenes</i> cells following recovery studies in enrichment medium				

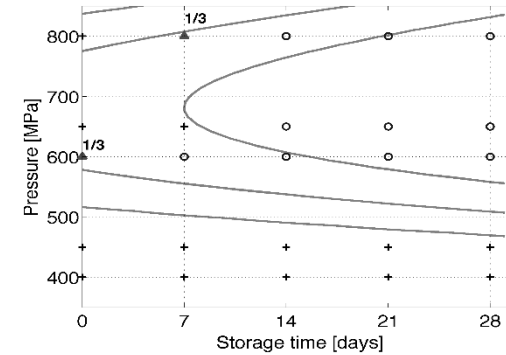

- **700 MPa** microbiologically stable product even after a **storage of 28 days**
- Not effective at the highest level of salt concentration, i.e., 35 g/L (nitrite of 75 mg/L) →  $a_w$
- pressure-induced injury may **enhance the bacteriostatic effect** of sodium chloride (SC) and sodium nitrite (SN) (or the resulting low  $a_w$ ) even at low concentrations



# High Hydrostatic Pressure

## Research evaluations

### Case study 2 : Controlling stability of apple juice

- Spoilage
  - *Issatchenka orientalis* (<3%) → most frequently isolated yeast species in fruit concentrates
- Other quality –nutritional issues
  - Enzymatic browning (PPO) - ascorbic acid oxidation - caramelisation - formation of browned polymers by oxidized lipids - Maillard reaction – precipitation of pectin (PME)
  - Vitamin C (<0.05 mg/g) 300 ppm
- Potential solution
  - High Hydrostatic Pressure treatment for the production of stable apple juice



[10.1016/j.ifset.2009.02.006](https://doi.org/10.1016/j.ifset.2009.02.006)

# High Hydrostatic Pressure

Research evaluations

## Case study 2 : Controlling stability of apple juice

- Characterisation of microbial & quality dynamics
  - During HHP (Pectin Methylesterase, Polyphenol oxidase)
  - Post-processing storage (spoilage : *Issatchenkia orientalis*, vitamin C)
- Defining stability interfaces of apple juice
  - Enzymatic quality indices (qualitative)
  - Spoilage target microorganism (quantitative: probabilistic modelling)

Processing

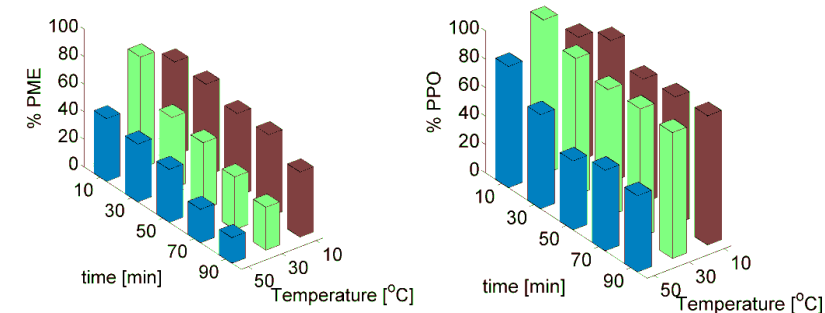

PME, PPO activity for a combination of t, T at 750 MPa

Post-processing

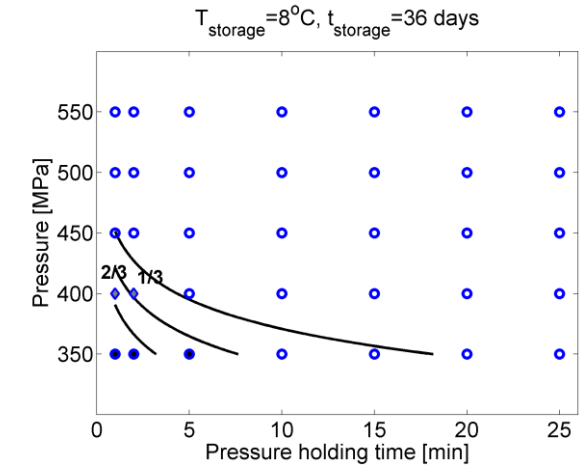

Probability of spoilage/no spoilage by *I. orientalis*

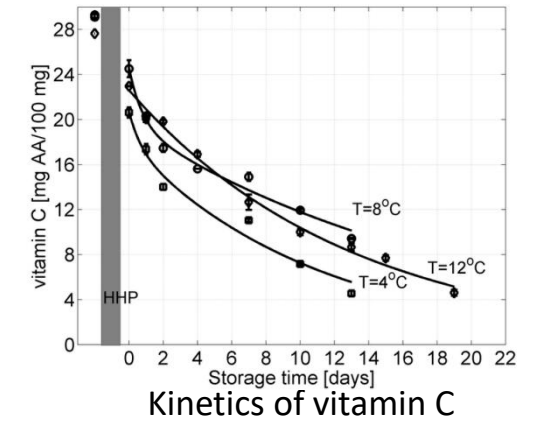

Kinetics of vitamin C

# High Hydrostatic Pressure

## Industrial applications

Table 1.1 Some commercially-available HP-processed food products (adapted from Leadley et al., 2003)

Product	Manufacturer	Country
Jams, fruit sauces, yoghurt and jelly	Meida-Ya	Japan
Mandarin juice	Wakayama Food Industries	Japan
Tropical fruits	Nishin Oil Mills	Japan
Beef	Fuji Ciku Mutterham	Japan
Guacamole, salsa dips, ready meals and fruit juices	Avomex	USA
Hummus	Hannah International	USA
Fruit and vegetable juices	Odwalla	USA
Ham	Hormel Foods	USA
Processed poultry products	Purdue Farms	USA
Oysters	Motivatit Seafoods	USA
Oysters	Goose Point Oysters	USA
Oysters	Joey Oysters	USA
Orange juice	Ultifruit	France
Fruit juices	Pampryl	France
Apple juice	Frubaca	Portugal
Sliced ham and tapas	Espuña	Spain
Fruit juices and smoothies	Orchard House	UK

Product	Process parameters	Purpose of treatment	Market share
Juices and beverages	400–600 MPa1–5 min	Microbial safety and extension of shelf-life	30%
Meat products (ham, cured meat, and cold cuts)	400–600 MPa1–5 min	Microbial safety	30%
Fruit and vegetable preparations (e.g., guacamole, baby food, dips, and salsa)	500–600 MPa5–10 min	Shelf-life extension and inactivation of enzyme (color preservation)	28%
Seafood and shellfish	250–350 MPa30–90 s	Removal of shell, increasing yield, inactivation of <i>Vibrio</i>	7%
Ready-to-eat meals	400–600 MPa1–5 min	Microbial safety and extension of shelf-life	3%
Dairy products	400–600 MPa1–5 min	Microbial safety and extension of shelf-life	2%

Source: Adapted from Hayashi (2002); Tonello-Samson (2018a).

Examples of high pressure-treated foods on the market (10.1111/1541-4337.12763)



### Unique success stories

- **Oysters:** adductor muscle is separated from the shell/inactivation of viruses and bacteria
- **Guacamole:** reduction of microbial load, biochemical and sensory aspects or polyphenoloxidase activity



# High Hydrostatic Pressure

## Advantages/disadvantages



- Pressure transfer independent of shape
- Avoid undesired reactions (e.g., Maillard)
- Retention of vitamins
- Low energy requirements
- Production of new (functional) products
- Quick return on high added-value products and intensive productions
- No formation of new chemical compounds



- High cost of initial investment
- Requirement of high levels of pressure for reduction of enzyme activity
- Microbial induced resistance
- Currently most processes are batch
- Some properties (color, texture) might change as a consequence of HPP



- Intrinsic characteristics of some food products make them unsuitable for HPP
  - $\text{pH} > 5 \rightarrow$  additional controls are required to prevent spore outgrowth
  - $a_w < 0.90 \rightarrow$  efficiency of HPP is drastically reduced

# Food technologies for food safety

- **Categories Based on Type of Energy or Physical Force:**
- **Electrical-based technologies:**
  - **Pulsed Electric Field (PEF)**
    - Definitions & basic principles
    - Antimicrobial mechanism of action
    - Research evaluations
    - Industrial applications and research evaluations
    - Advantages/disadvantages
  - **Cold Atmospheric Plasma (CAP)**

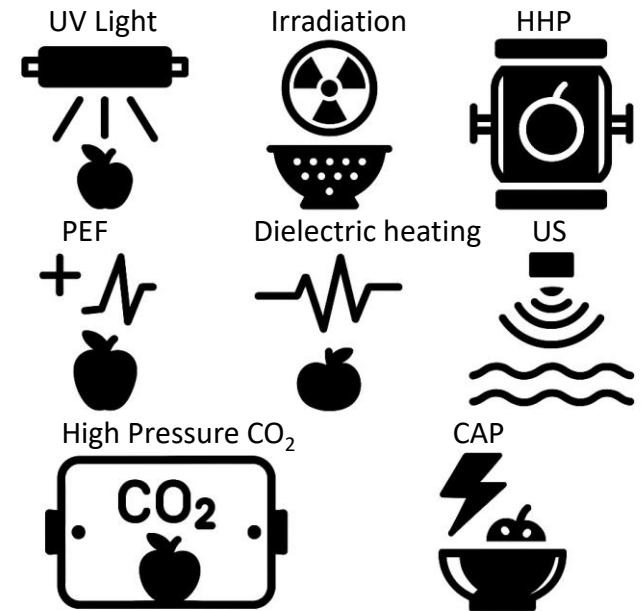

# Pulsed Electric Field (PEF)

## Definitions & basic principles

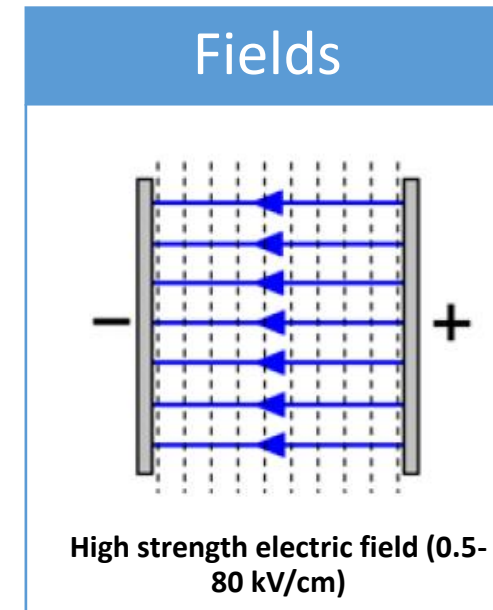
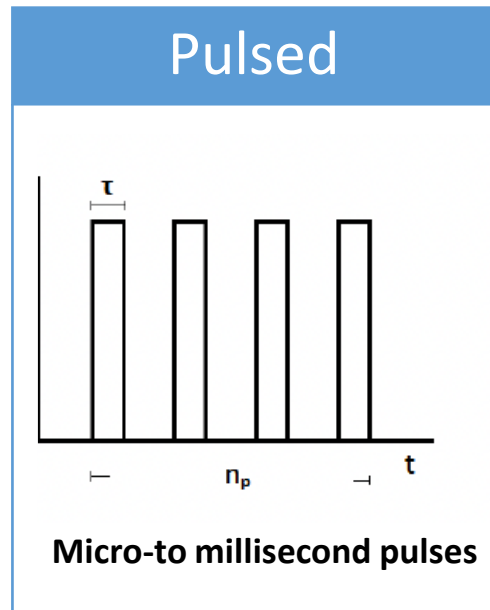

- ✓ Basic principle: electroporation
- ✓ Target: any system that contains cells (plant, animal or microbial)
- ✓ Aim: microbial inactivation or cellular permeabilization

# Pulsed Electric Field (PEF)

Definitions & basic principles

Antimicrobial mechanism of action

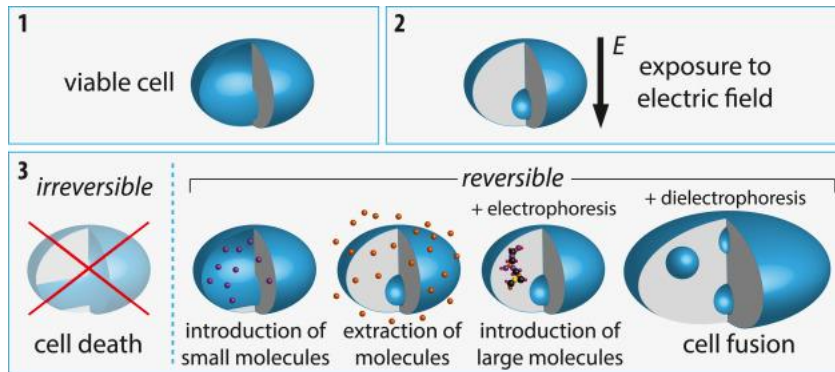
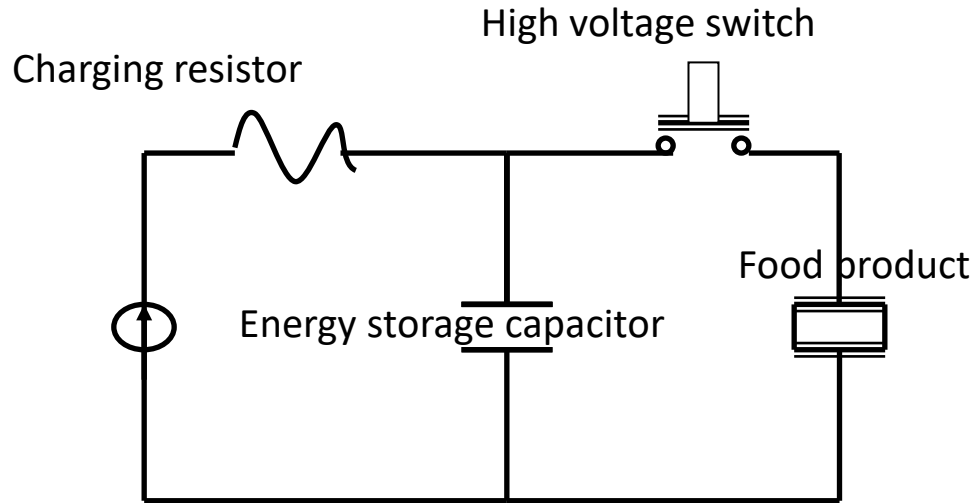

A viable cell *in vitro* or *in situ* (1) is exposed to a sufficient electric field and time (2), depending on the conditions, irreversible or reversible changes with interesting applications ensue (3) (<https://doi.org/10.1016/C2018-0-04808-2>)

## Parameters

Voltage (kV/cm)

Temperature (°C)

Time (µsec)

Pulses (number-frequency- shaper)

Flow rate (ml/min)

Field strength

Electric conductivity

## Treatment medium characteristics

Medium conductivity

pH

Matrix effects

## Microbial characteristics

Cell size

Cell morphology

Cell growth phase

Yeast cells before treatment

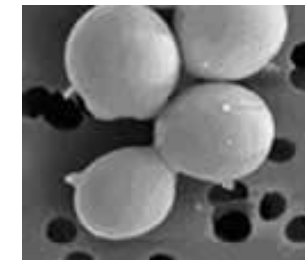

Yeast cells after treatment

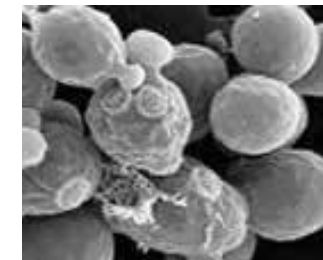

# Pulsed Electric Field (PEF)

Research evaluations

## Case study 1 : Pulsed electric field (PEF) processing of oat-based milk alternative

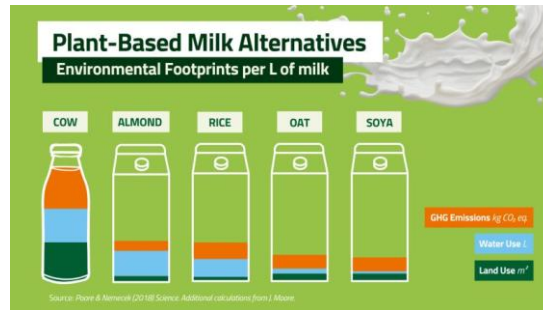

Near neutral pH ~ 6.5  
Variable composition

- Quantify the microbial resistance of two model spoilage strains of *L. plantarum*
- Estimate the contribution of the thermal effect during the PEF processing of oat-based beverage

$$F_{T_{ref}}^z = \int_0^t 10^{\frac{T-T_{ref}}{z}} dt = D \times \left( \log_{10} \frac{N_0}{N} \right)_{Thermal}$$

$$\left( \log_{10} \frac{N_0}{N} \right)_{Electroporation} = \left( \log_{10} \frac{N_0}{N} \right)_{PEF} - \left( \log_{10} \frac{N_0}{N} \right)_{Thermal}$$

<https://doi.org/10.1016/j.ifset.2024.103691>

# Pulsed Electric Field (PEF)

Research evaluations

## Case study 1 : Pulsed electric field (PEF) processing of oat-based milk alternative

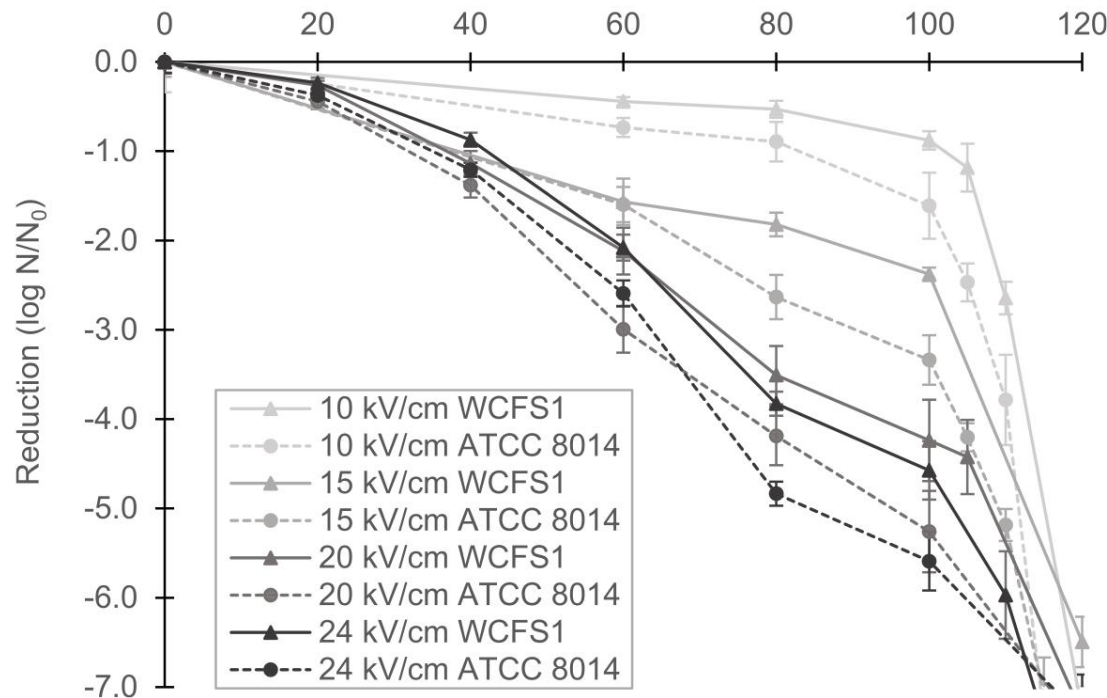

PEF inactivation of *L. plantarum* strains ATCC 8014 and WCFS1 in oat beverage at 15 L/h flow rate: Effect of specific energy.

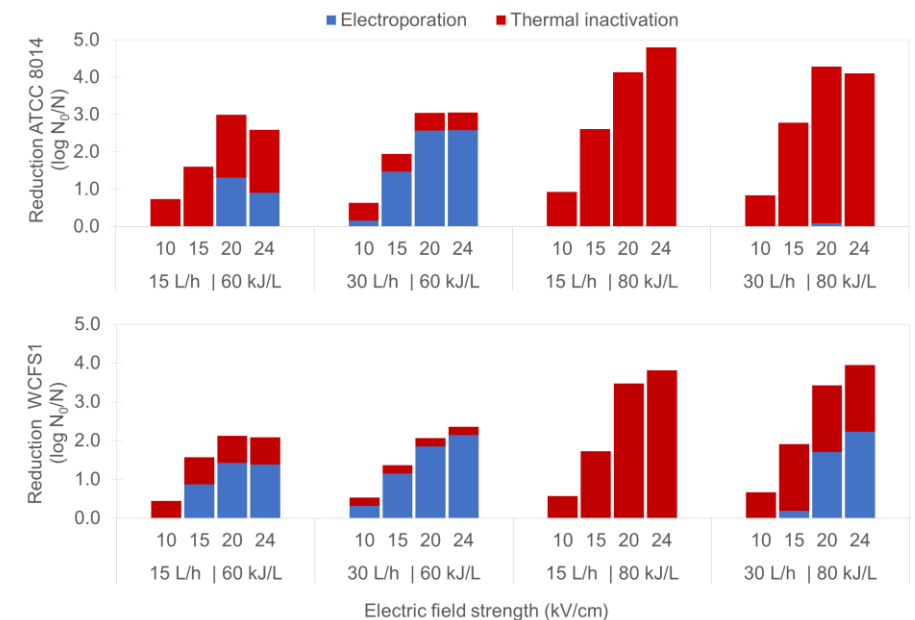

<https://elea-technology.com>

# Pulsed Electric Field (PEF)

## Industrial applications



### PEF for drying

Improve drying with PEF. Accelerate drying, improve quality, faster process times and energy savings



### PEF for olive oil

Improve olive oil processing at lower temperatures, increase yield and gain more EVOO.



### PEF for wine

Faster extraction, enhanced quality, increased yield, reduced costs, controlled fermentation and spoilage.

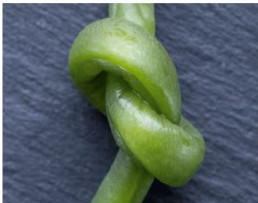

### PEF for vegetables

Improve vegetable processing with PEF. Up to 50% faster blanching, better cutting and improved flexibility.

## Unique success stories

**Potato industry** : *eliminate preheating step, reducing the energy and water consumption, production of fries with fewer fines during cutting, tissue softening, smoother cutting surface, reduction of oil absorption by approx. 10%*

Product	Treatment regime	Parameters improved compared with untreated samples	Chamber characteristics	References
Liquid egg	25.8 kV/cm; 37C; 100 pulses; 4 μs	Effective in processing egg product with shelf-life of 10 days	Continuous chamber, coaxial stainless steel electrodes; 0.6 cm gap, vol. of 28.6 cm <sup>3</sup>	Martin-Beloso <i>et al.</i> (1997)
Pea soup	25–33 kV/cm; 53–55C; 10–30 pulses; 2 μs	Reduction of <i>E. coli</i> by log reduction of 6D	Ditto	Vega-Mercado <i>et al.</i> (1997)
Yoghurt	23–38 kV/cm; 63C; 20 pulses; 100 μs	Effectively reduced microorganisms by 2D	Static chamber; parallel stainless steel electrodes; 2 cm gap; vol. 157 cm <sup>3</sup>	Dunn and Pearlman (1987)
Coconut	0.1–2.5 kV/cm; 60C; 0–200 pulses; 100 μs	More milk yield (20%)	Ditto	Ade-Omowaye <i>et al.</i> (2000)
Potato processing	0.4 kV/cm; 60C; 2 pulses; 575 μs	Freezing time reduced and the quality and rehydration of samples improved	Polypropylene cylindrical tube with inner diameter of 26 mm and an electrode at the bottom, 0.1 cm gap	Jalte <i>et al.</i> (2009)
Sugar beet	2.5 kV/cm; 20C, 20 pulses, 5 μF	Increased mass transfer rates and allows for reduced extraction temperature	Static chamber, parallel stainless steel electrodes, 3.8 cm gap	Eshtiaghi and Knorr (2002)
Soybean protein isolates	0–40 kV/cm; 500 pulses; 0–54 μs	Controlled PEF treatment was able to modify their structure and functions to produce desired products	Six co-field flow tubular chambers; 0.29 cm gap	Li <i>et al.</i> (2007)
Meat and fish treatment	2.5 kV/cm; 30C; 1–64 pulses, 100 μs	Effectively reduced microbial load by 6D	Continuous chamber, flat circular parallel stainless steel electrodes, 0.5 cm gap, vol. 5.7 mL	Barsotti <i>et al.</i> (2001)
Carrots	0.22–1.60 kV/cm; 18C, 5 pulses, 405 μs	Resulted in increased permeability index of carrots and mass transfer rate during osmotic dehydration	Static chamber, parallel stainless steel electrodes, 3 cm gap	Rastogi <i>et al.</i> (1999)
Apple slices	1.0 kV/cm; 24 or 45C; 20 pulses, 400 μs	Higher rehydration capacity was achieved in sample pre-dried with HIPEF	Ditto	Taiwo <i>et al.</i> (2002)

## Applications of Pulsed electric Field (PEF) in food processing (10.1111/jfpp.12940)



Potato outlet of an industrial PEF system in a French fry processing line. (Elea GmbH 2020)



Level of crust separation after frying on PEF-treated (left) and untreated (right) French fries. (Elea GmbH 2020)

# Pulsed Electric Field (PEF)

## Advantages/disadvantages



- Shelf-life extension
- Retention of organoleptic properties
- Products with improved properties (under frozen conditions)
- Energy & Cost Efficiency
- Enhanced Extraction & Mass Transfer
- Better Structural Modifications

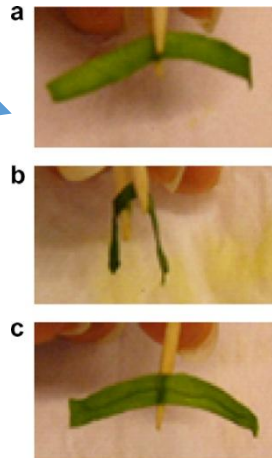

- Few world suppliers
- Reduction of enzyme activity requires high energy levels
- Electrochemical reactions (depending on type of electrodes)
- Process Optimization Required
- High Initial Investment



# Food technologies for food safety

- **Categories Based on Type of Energy or Physical Force:**
- **Electrical-based technologies:**
  - Pulsed Electric Field (PEF)
  - **Cold Atmospheric Plasma (CAP)**
    - Definitions & basic principles
    - Antimicrobial mechanism of action
    - Research evaluations
    - Industrial applications and research evaluations
    - Advantages/disadvantages

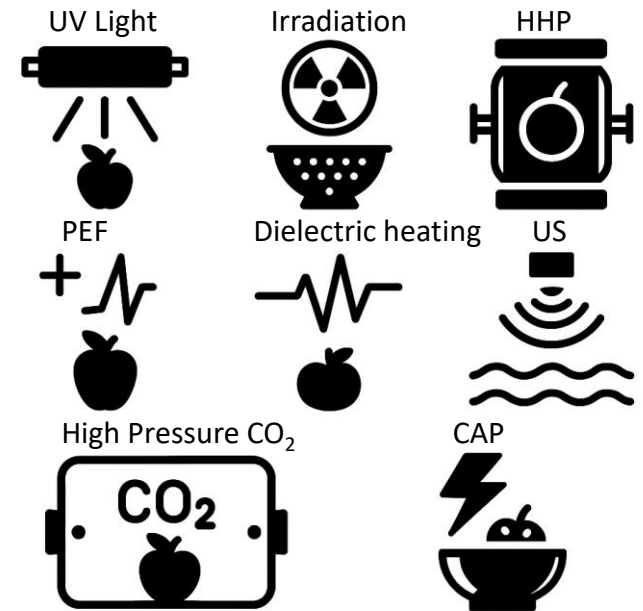

# Cold atmospheric plasma

## Definitions & basic principles



- Ionised Gas
- Fourth state of matter
- Highly Conductive
- Constitutes 99% of the universe although limited occurrence on Earth

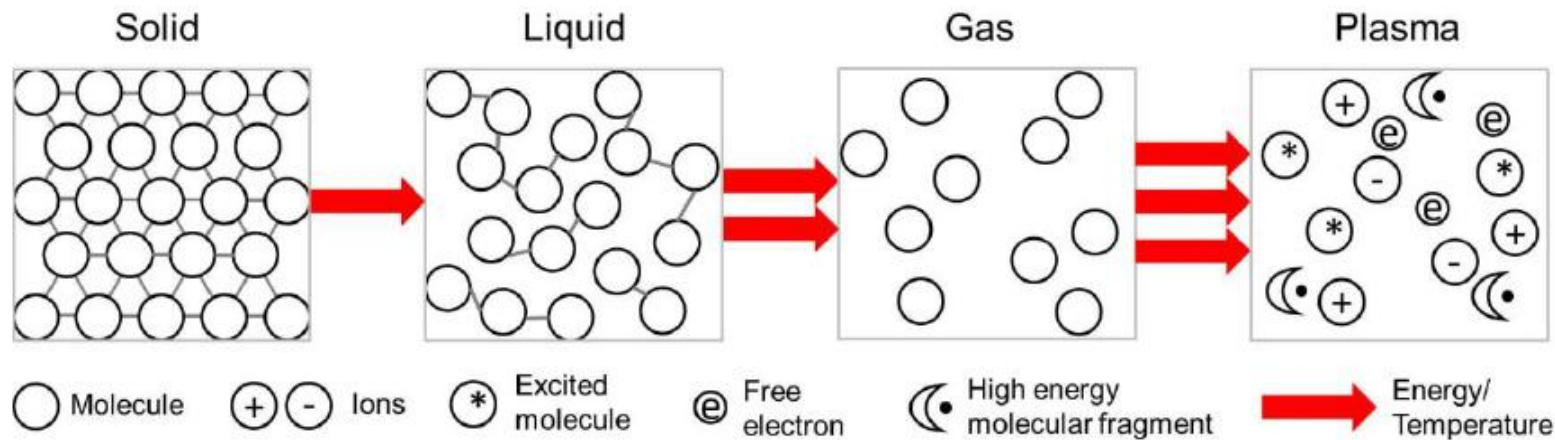
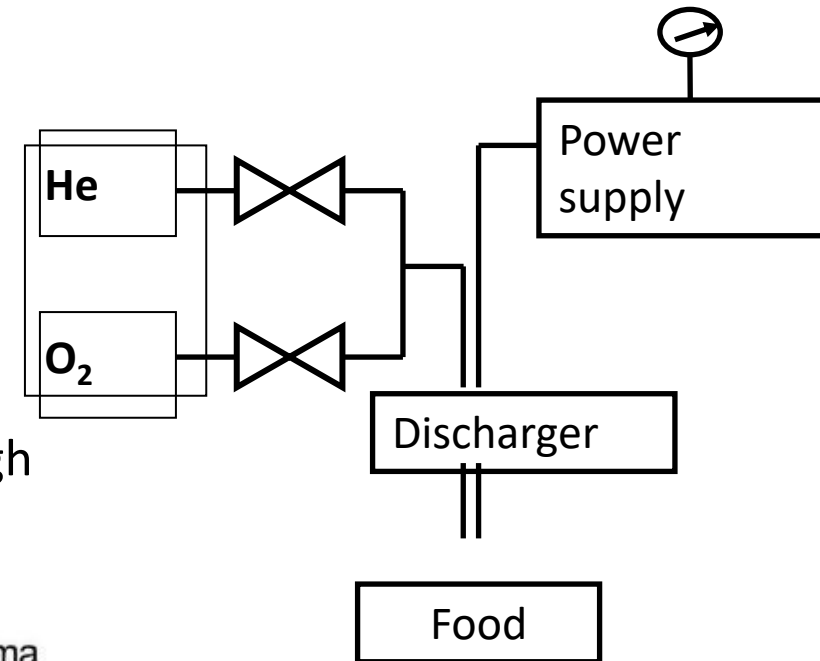

- Parameters**
- Type of gas
  - Time of process
  - Gas flow
  - Voltage
  - Concentration of radicals
  - Food properties

# Cold atmospheric plasma

## Definitions & basic principles

### Plasma generation methods

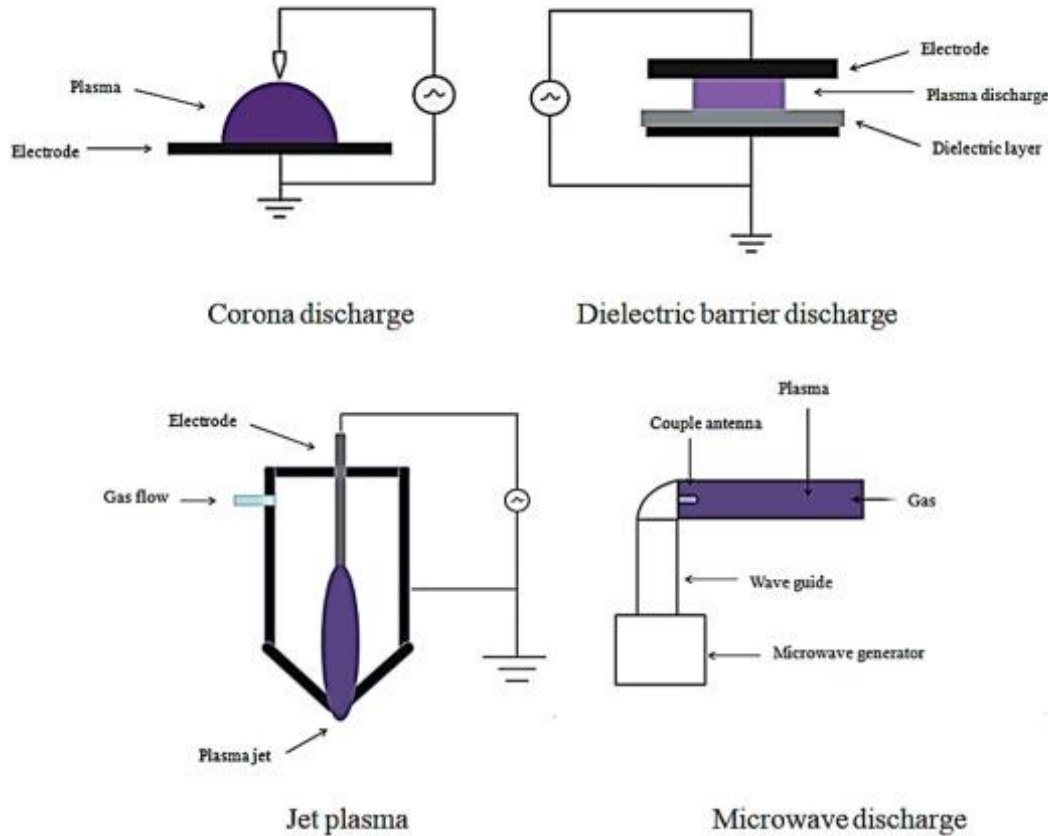

### Type of treatments

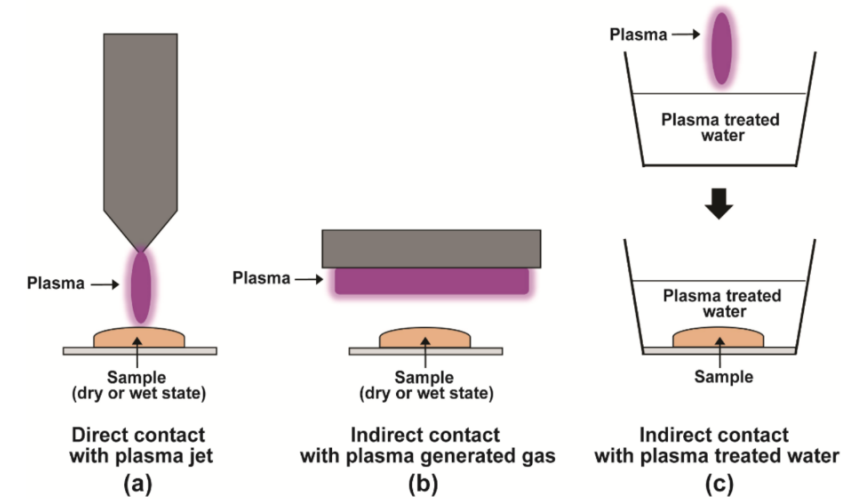

Strategies used for plasma treatment. Samples can be treated in a dry or wet state. (a) The sample is directly exposed to a plasma jet. (b) The sample is indirectly exposed to a gas produced from plasma. (c) The sample is submerged in plasma-treated water <https://doi.org/10.3390/jof8020102>

Plasma discharge techniques: corona discharge, dielectric barrier discharge, Jet plasma, and microwave discharge <https://doi.org/10.1016/j.jafr.2023.100747>.

# Cold atmospheric plasma

## Antimicrobial mechanism of action

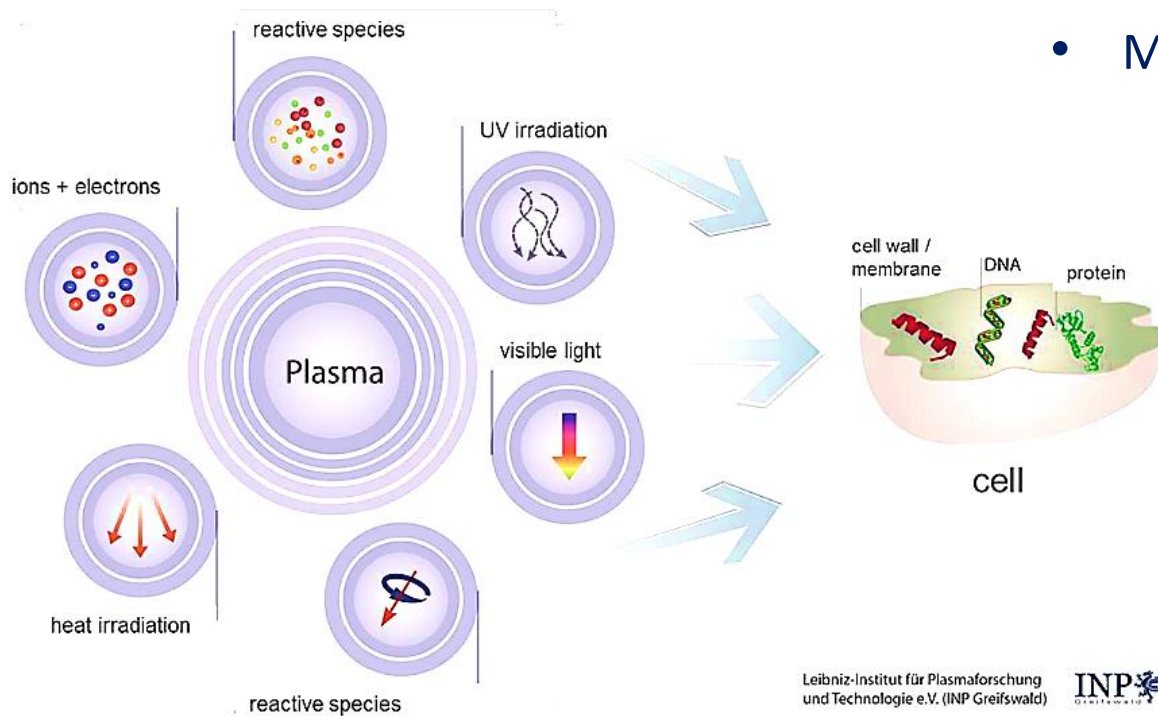

Leibniz-Institut für Plasmaforschung und Technologie e.V. (INP Greifswald) INP

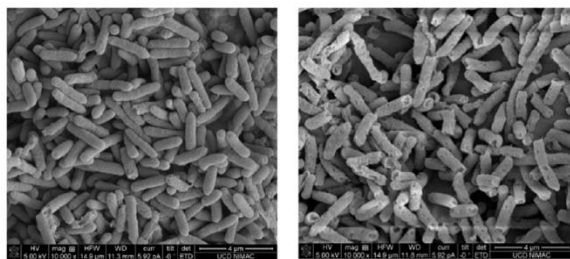

Before CAP treatment    After CAP treatment

- Mechanisms of action for microbial inactivation
  - Charged particles + radicals → rupture cell membrane
  - Reactive species → oxidation lipids, amino acids, nucleic acids → microbial death
  - UV photons → modification microbial DNA

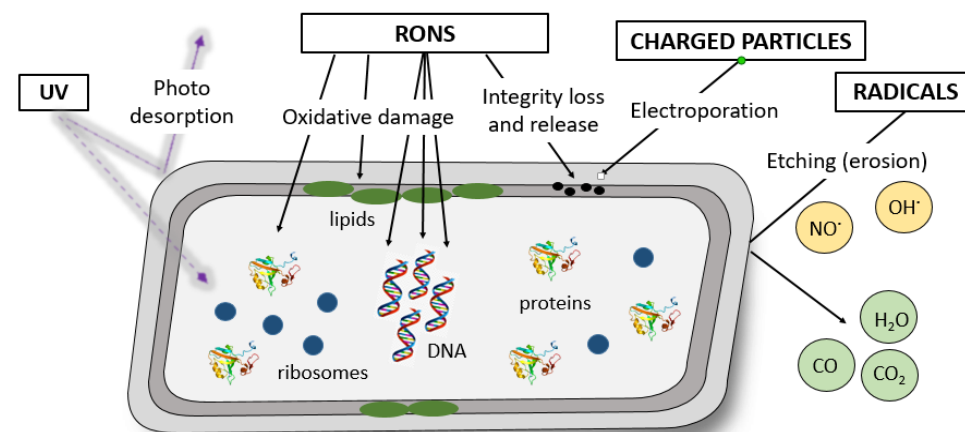

Antimicrobial mechanism of action

# Cold atmospheric plasma

Research evaluations

## Case study 1: Decontamination of bean sprouts

- Nutritional value
- Health benefits
- Simple production practice
- Foodborne pathogens

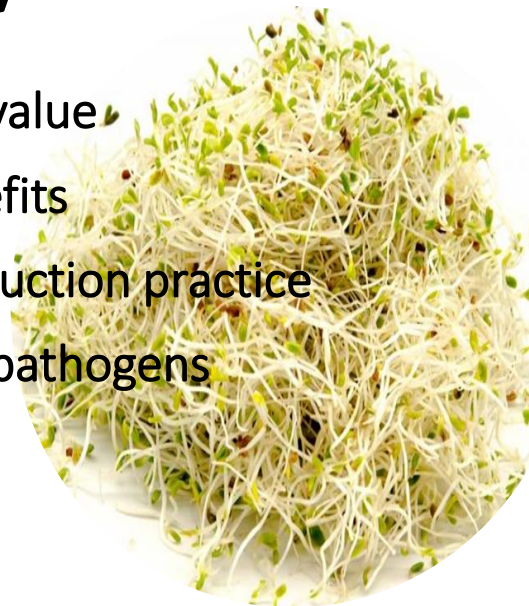

Bacteria	Year	Prevalence	Source (Sprouts)	Country
<i>E. coli</i> O103	2020	51	Clover sprouts	USA
<i>Salmonella</i>	2016	26	Alfalfa	USA
<i>E. coli</i> O121	2014	19	Alfalfa	USA
<i>E. coli</i> O26	2012	29	Raw clover	USA
<i>E. coli</i> O104:H4	2011	3842	Fenugreek	Germany
<i>Salmonella</i>	2010	190	Bean sprouts	UK

Summary of microbial infection outbreaks associated with sprouts from 2010 to 2020  
<https://doi.org/10.3390/nu13082882>

Foodborne pathogens on seeds

Sprouting: Warm temperatures and humidity

Consumption of raw contaminated sprouts

<https://doi.org/10.1038/s41598-021-97823-1>

# Cold atmospheric plasma

Research evaluations

## Case study 1: Decontamination of bean sprouts

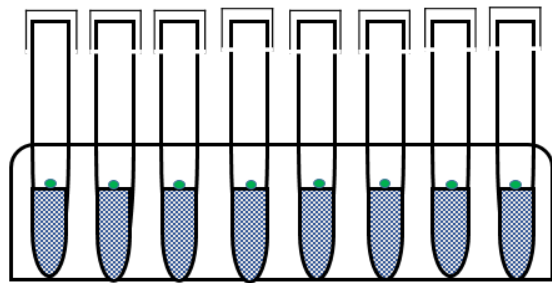

Use of plasma activated water to irrigate bean sprouts

<https://doi.org/10.1038/s41598-021-97823-1>

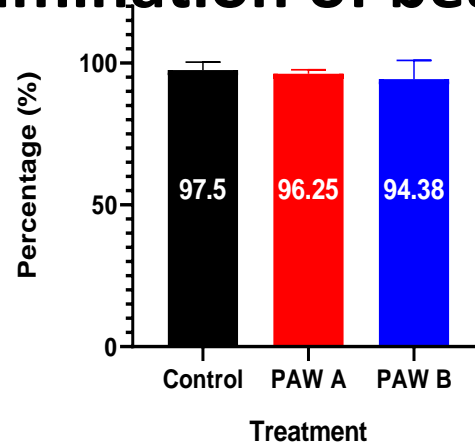

Percentage of mung bean seeds sprouted within 96 h under different combined plasma treatments

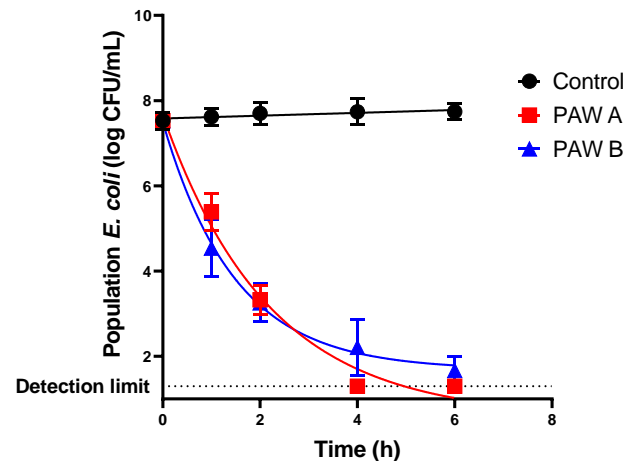

Inactivation of *E. coli* in relation to exposure time (h)

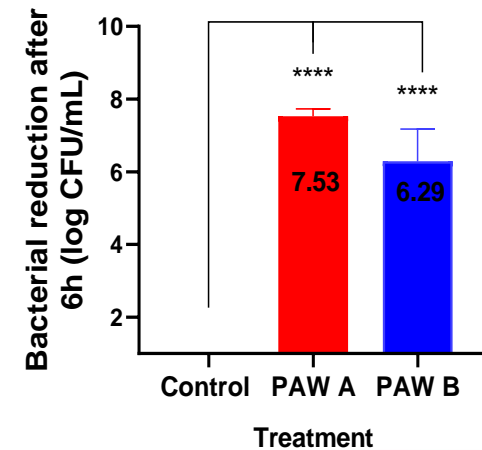
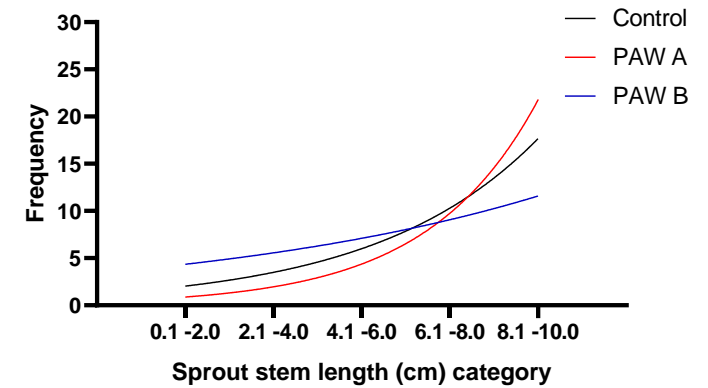

Total reduction of *E. coli* (log CFU/mL) within 6 h of exposure to control, PAW A and PAW B

# Cold atmospheric plasma

(Industrial) pilot applications

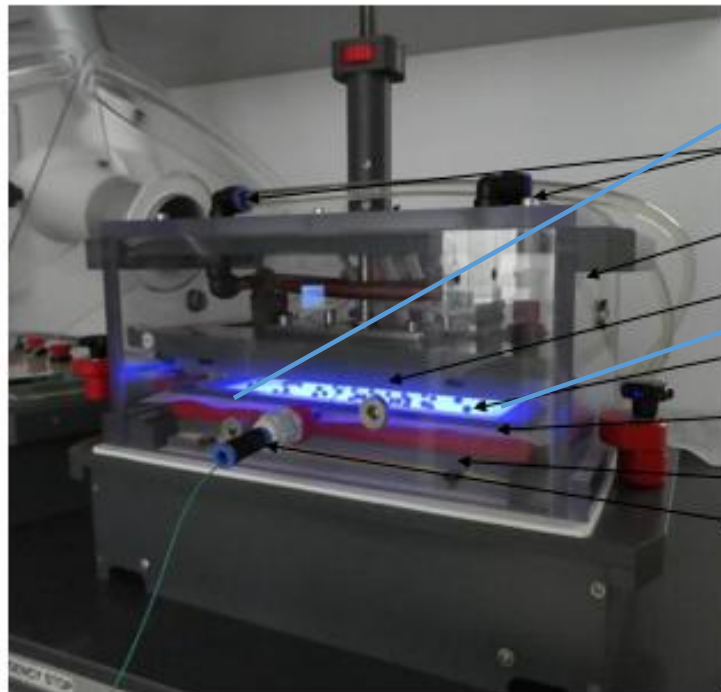

Dielectric coplanar surface barrier discharge (ATB, Germany)

- Gaseous inlets
- Plasma chamber
- Top plasma electrode
- Sample (mung bean seeds)
- Sample
- Bottom plasma electrode
- Temperature probe

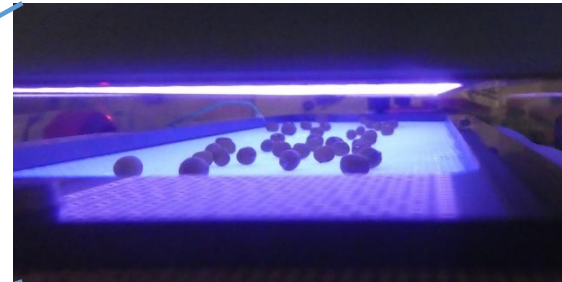

Microwave-induced plasma torch for treatment of spices (INP, Germany)



Rotary atmospheric plasma activation for seeds (advancedplasmatech.ie)

# Cold atmospheric plasma

## Advantages/Disadvantages



- Process without heat generation
- Application on packaged foods and on surfaces
- Effective microbial decontamination
- Minimal use of chemicals
- Energy efficiency
- Non-thermal processing
- Modification of Food Properties
  - Improve functional characteristics of certain foods (e.g., oxidation of food proteins for improved emulsification).



- Limited penetration depth
- Limited studies and consequently industrial applications
- Production of high levels of ozone
- Possible negative effect on colour of products
- Not suitable for products with high fat content
- Regularoty framework not available
- Potential packaging material compatibility

# Food technologies for food safety

- **Categories Based on Type of Energy or Physical Force:**
- **Acoustic-based technologies:**
  - **Ultrasound (US)**
    - Definitions & basic principles
    - Antimicrobial mechanism of action
    - Research evaluations
    - Industrial applications and research evaluations
    - Advantages/disadvantages
  - **Hydrodynamic Cavitation (HC)**

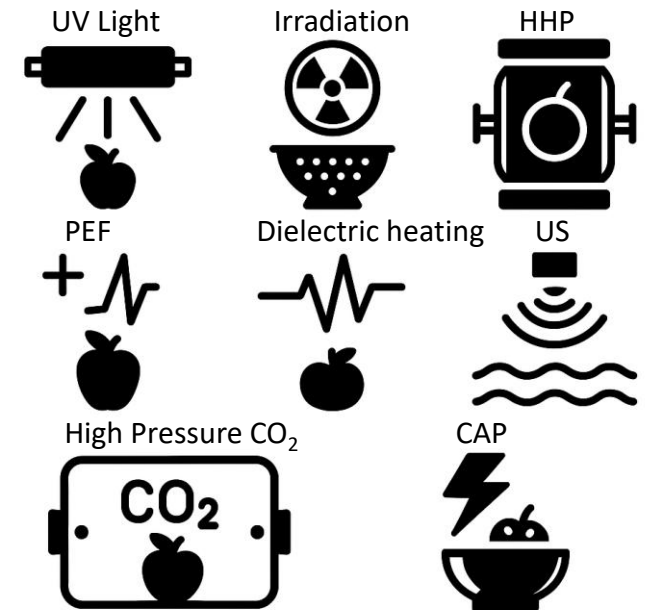

# High Power Ultrasound

Definitions & basic principles

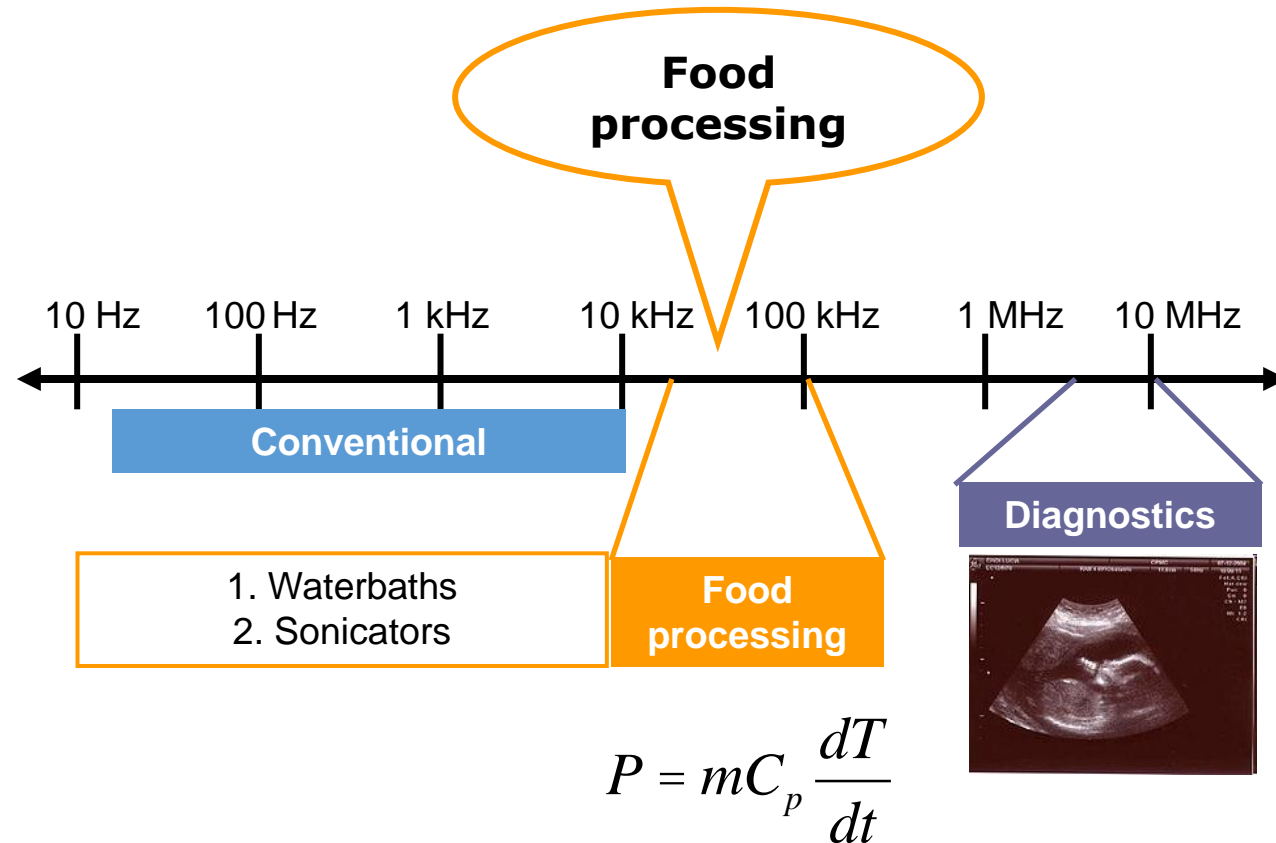

**Absolute Ultrasonic Power (P)**

## Parameters

- Frequency (kHz)
- Amplitude ( $\mu\text{m}$ )
- Intensity ( $\text{W}/\text{cm}^2$ )
- Time
- Temperature/Pressure
- Properties of food

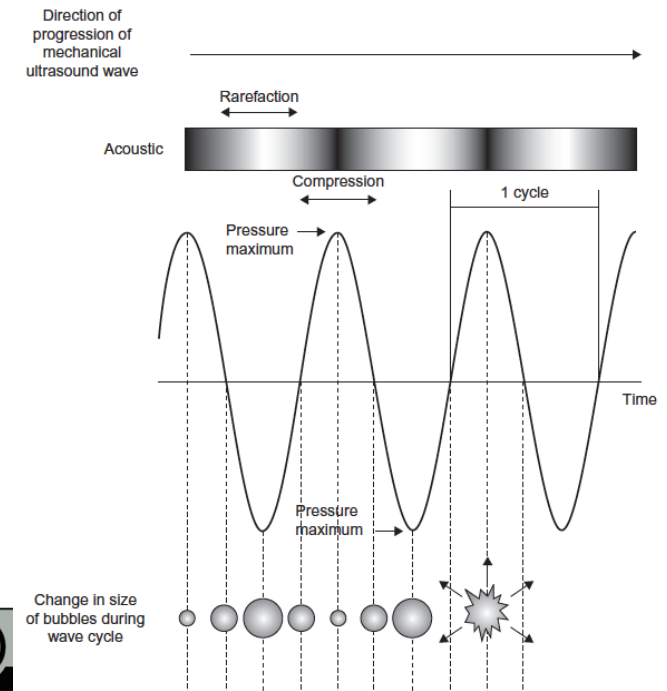

# High Power Ultrasound

## Antimicrobial mechanism of action

- Products of sonolysis: Free radicals ( $H^\bullet$ ,  $O^\bullet$ ,  $OH^\bullet$ ,  $HO_2^\bullet$ ) and  $H_2O_2$

- Cavitation

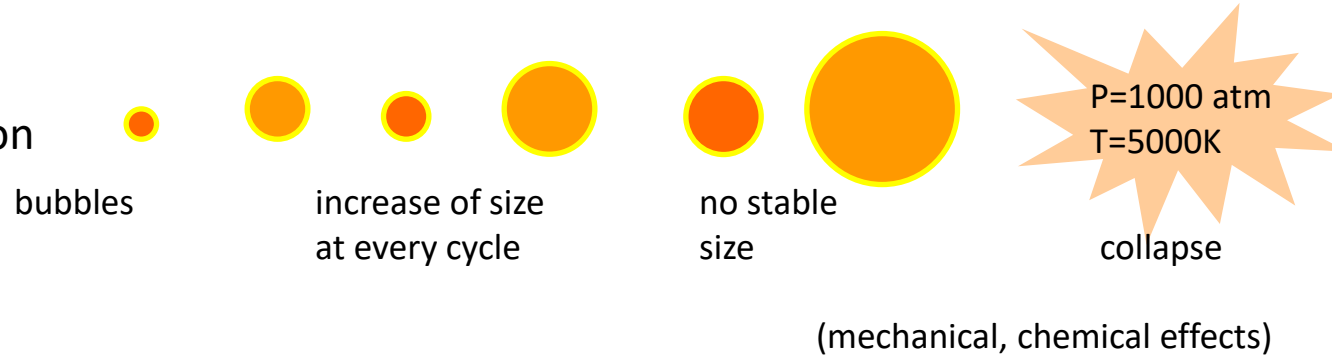

- **Mechanical forces:** pressure gradients are generated during the collapse of cavitation bubbles
- **Shear forces:** micro-streaming generation
- **Chemical effects:** free radicals ( $H^\bullet$ ,  $O^\bullet$ ,  $OH^\bullet$ ,  $HO_2^\bullet$ ) and  $H_2O_2$

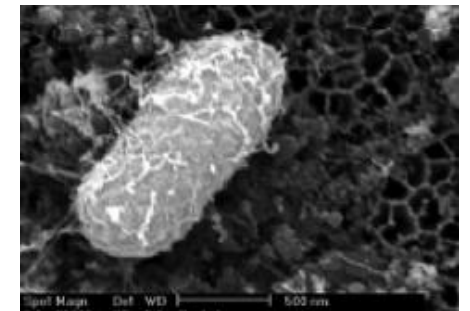

Controlled *E. coli* K12 cells

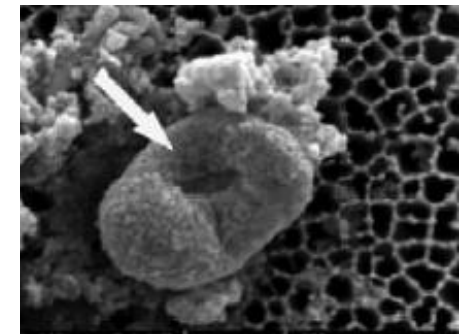

*E. coli* K12 cells sonicated at 40°C for 3 min

# High Power Ultrasound

Research evaluations

## Case study 1 : Decontamination of ready to eat salads by alternative to chlorination



Ready to eat salads

- Potential solution

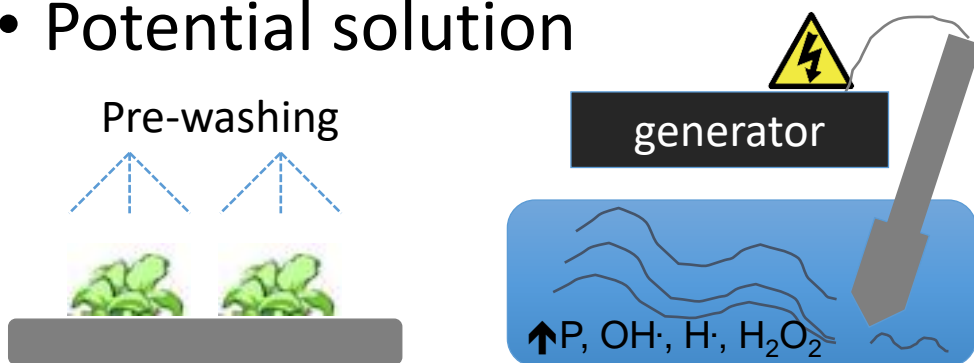

Type of leafy green vegetable	Microorganism	Year	Location
Lettuce	<i>Escherichia coli</i> O157:H7	1995	USA
	<i>Listeria monocytogenes</i>	1979	USA
	<i>Shigella sonnei</i>	1983	USA
	<i>Salmonella</i> Typhimurium DT104	1994	Norway
	<i>Salmonella</i> Newport	2005	Spain
	<i>Campylobacter jejuni</i>	1996	USA
	Baby lettuce leaves	<i>Cyclospora cayatenansis</i>	1997
Shredded lettuce	<i>Shigella sonnei</i>	1986	USA
Iceberg lettuce	<i>Shigella sonnei</i>	1994	Norway, Sweden, UK
Lettuce salad	<i>E. scherichia coli</i> O157:H7	1995	Canada
	Hepatitis A	1986	USA
Parsley	<i>Giardia</i>	1989	USA
	<i>Shigella sonnei</i>	1998	USA
Basil	<i>Salmonella</i> Senftenberg	2007	Israel
	<i>Cyclospora cayatenansis</i>	1997	USA

Examples of some outbreaks of infections epidemiologically associated with leafy green vegetables and their RTE salads <https://doi.org/10.1016/j.anaerobe.2011.04.004>

# High Power Ultrasound

Research evaluations

## Case study 1 : Decontamination of ready to eat salads by alternative to chlorination

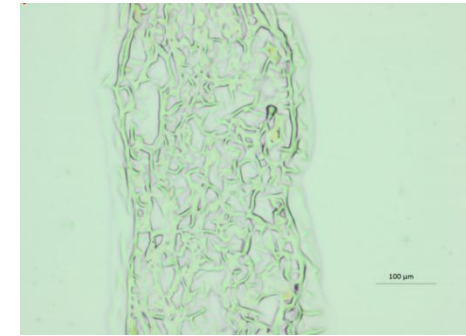
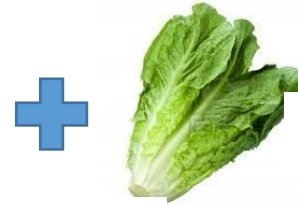
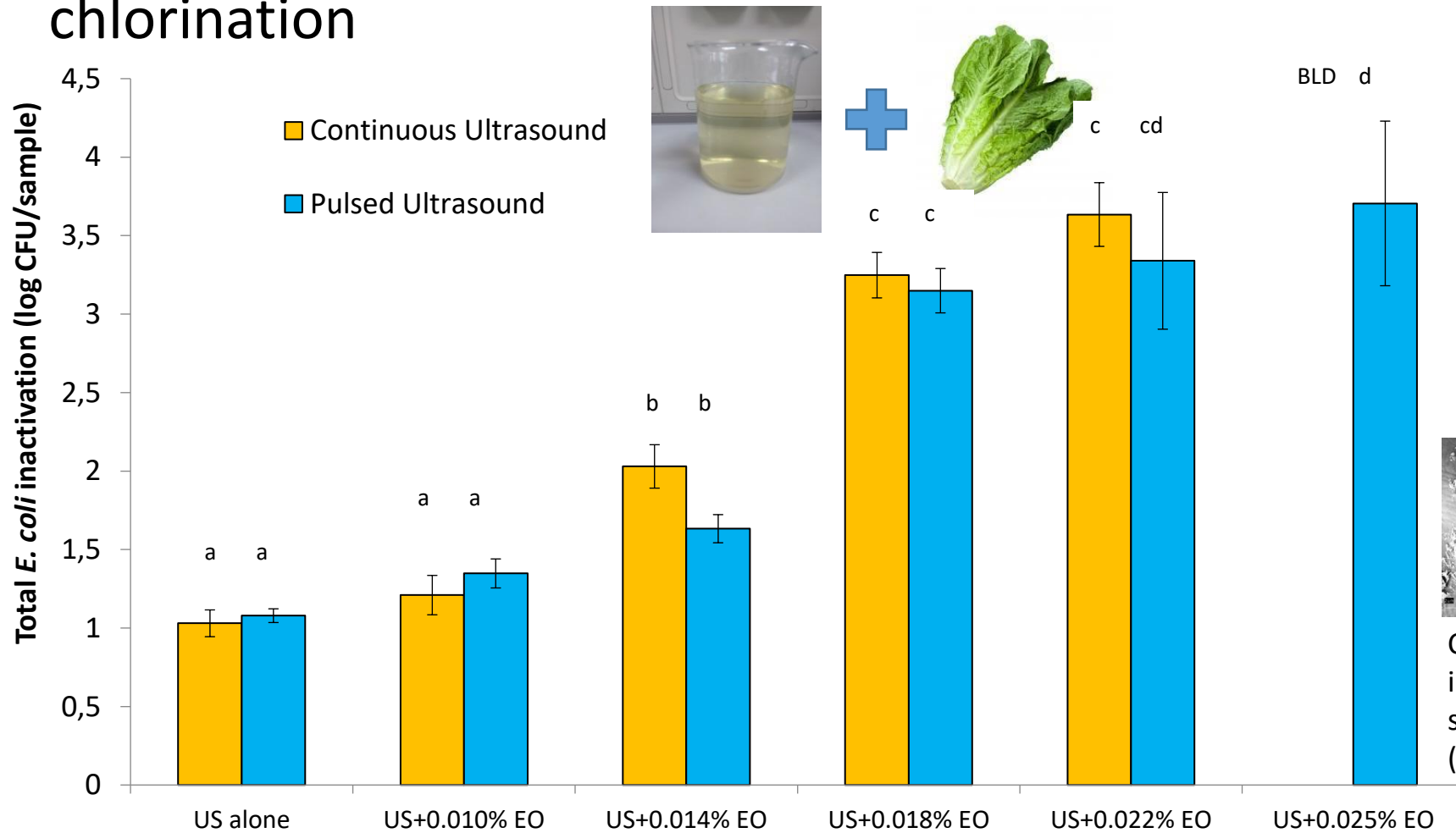

Continuous US+ 0.025 % (v/v) EO (x 100)



Control inoculated sample (x 10.000)

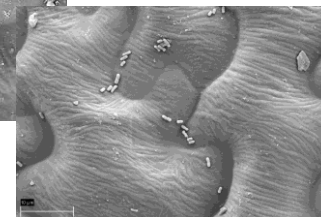

Pulsed US (10s on/6s off treatment) (x 5.000)

# High Power Ultrasound

## Research evaluations

- **Case study 2** : Evaluating efficiency of ultrasound for processing of reconstituted Infant Milk Formula (IMF)



Product	Country	Number of samples	Aerobic plate counts (cfu/g)					Cronobacter positive samples (%)
			<10 <sup>2</sup>	10 <sup>2</sup> -10 <sup>3</sup>	10 <sup>3</sup> -10 <sup>4</sup>	10 <sup>4</sup> -10 <sup>5</sup>	>10 <sup>5</sup>	
Follow up formula <sup>a</sup>	Brazil	31	30	1				
	Korea	24	21	3				
	Malaysia	12	5(1) <sup>c</sup>			4	3 (1)	
	UK	38	22	12	4(1)			
	Indonesia	0	ND <sup>d</sup>					
	Portugal	20	18	2				
	Jordan 1	6	6				1	
	Jordan 2	5	ND					
	Total	136	102	18	4	4	3	1 (0.7)
	Infant foods	Brazil	0					
Korea		6	2				4	
Malaysia		18	11	1	1	1(1)	4(2)	
UK		64	55	5	2		2	6
Indonesia		15	ND					6
Portugal		30	23	8				3
Jordan 1		21	12(1)	7	1		1	4
Jordan 2		25	ND					3
Total		179	103	21	4	1	11	22(12)
Herbal tea		Jordan 1	3	3				
	Previous infant food published data <sup>b</sup>	UK	49	35	8	3	3	5 (10)

Microbiological analysis of follow up formulas and infant foods 10.1016/j.ijfoodmicro.2009.08.005

- Potential solution

- decontamination of reconstitute IMF by mild heat treatments to retain nutritional properties of product

**NICROBIAL OUTBREAKS OF RECONSTITUTED INFANT MILK FORMULA IN IMMUNOCOMPROMISED INFANTS**

**INFECTION RATE 33%**

**MORTALITY RATE 40%**

**COMMON CONTAMINANTS**  
*Cronobacter sakazakii*, *Salmonella*

# High Power Ultrasound

## Research evaluations

- **Case study 2** : Evaluating efficiency of ultrasound for processing of reconstituted Infant Milk Formula

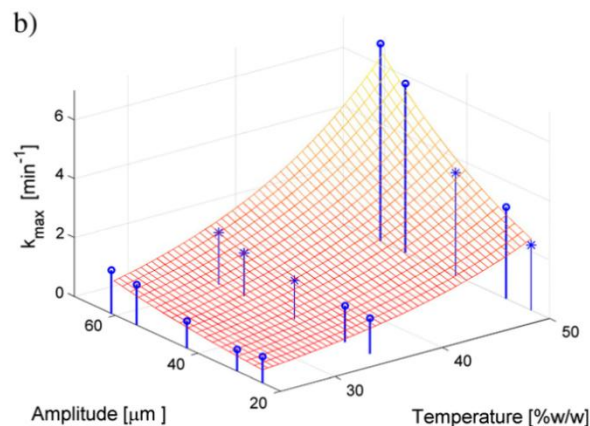
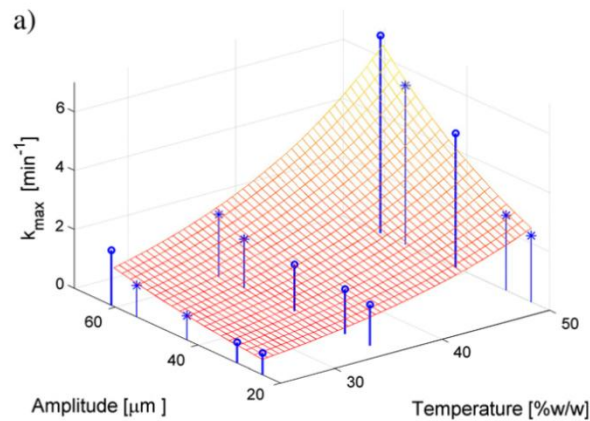

$$k_{\max 1}(T, Amp) = \frac{\ln 10}{AsymD_{ref}} \cdot \exp\left(\frac{\ln 10}{z}(T - T_{ref})\right) \times \exp\left(\frac{\ln 10}{z_{Amp}}(Amp - Amp_{ref})\right)$$

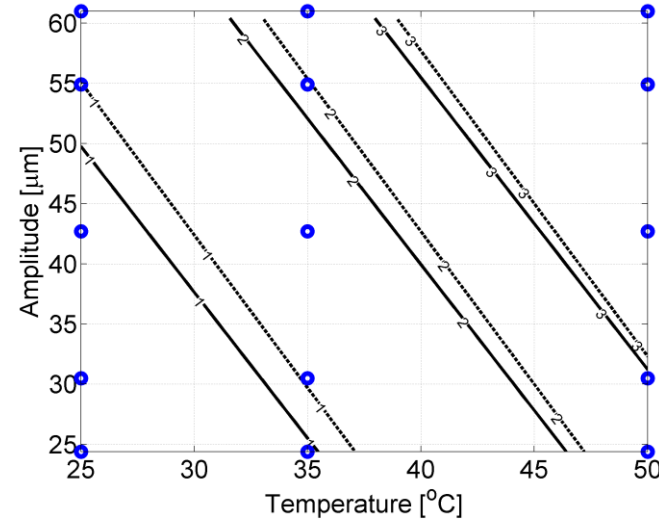

Iso-rate contour plots of *Cronobacter sakazakii* ATCC 08155 and ATCC 11467

- *C. sakazakii* resistance on ultrasound treatments is temperature and amplitude dependent
- Difference on resistance between strains allows to select a specific indicator for process optimisation

[10.1016/j.ijfoodmicro.2010.05.028](https://doi.org/10.1016/j.ijfoodmicro.2010.05.028)

Modelling the specific inactivation rate  $k_{\max 1}$  of *C. sakazakii* strain ATCC 11467 (a), NCTC 08155 (b)

[www.univ-ab.pt](http://www.univ-ab.pt)

# High Power Ultrasound

Industrial applications

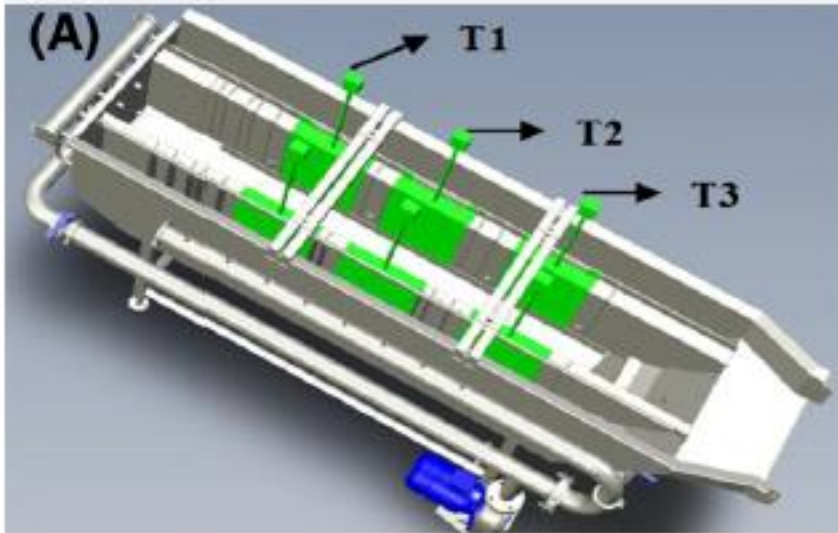

Continuous-flow ultrasonic washing system for fresh produce surface decontamination Zhou et al., 2012

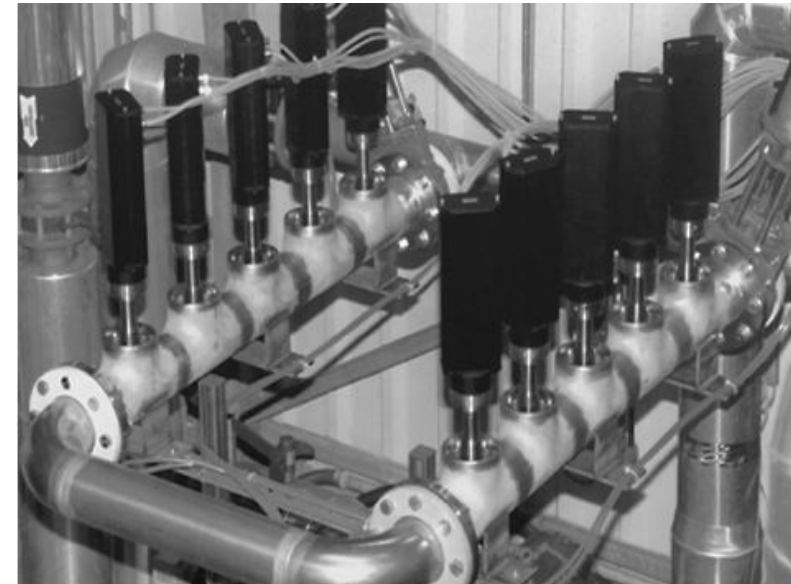

1kW (20 kHz) continuous system



## UI researchers use ultrasound to make food safer

URBANA — Food contaminated by *E. coli* bacteria sends more than 2,000 people in the U.S. to the hospital a year, but University of Illinois food scientists have developed a new way to make one source of sometimes contaminated food, fresh produce, much safer.

Produce such as spinach and lettuce is typically run through a continuous chlorine wash, but this eliminates only 90 percent of bacteria that can be present, says UI food processing professor Hao Feng.

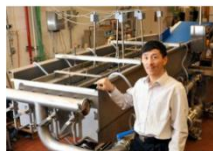

Photo by: Heather Colt/The News-Gazette  
Hao Feng talks about the equipment used to reduce *E. coli* on spinach.

ADEKIA  
www.adekia.com

## SCIENTIFIC AMERICAN

Subscribe News & Features Topics Blogs Videos & Podcasts Education Citizen Science

Health > News 4 Email Print

## Sound Barrier: Can High-Power Ultrasound Protect Produce from Pathogens?

A litany of food scares—and rules for organic produce—have pushed the industry to seek new solutions for food safety

March 19, 2012 | By Clare Leschin-Haar

Perfectly sanitized dimpled spinach leaves or tender greens like baby lettuce has been high on the wish list of the \$3.1-billion bagged salad industry since its inception.

The race to develop better wash systems for cleaning took off in earnest in 2006, after the high profile *E. coli* O157:H7 outbreak linked to bagged spinach killed five people and sickened more than 200, leaving the

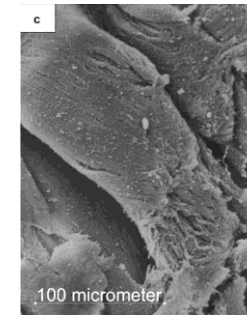
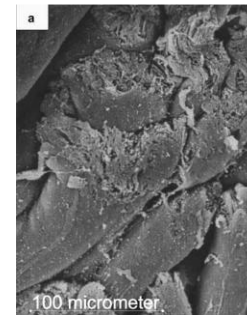

Meat curing



De-foaming



REPUBLIC  
and Kapodistrian  
University of Athens



# High Power Ultrasound

## Advantages/disadvantages



- Improvement of quality properties
  - Reduction of enzyme activity
  - Retention of turbidity
  - Minimal flavour loss in liquid foods
  - Increase in homogeneity and the breakdown of agglomerates of bacteria
- Alternative process
  - Low operation costs, low initial set-up cost
  - Low energy consumption
- Multiple applications
  - Homogenization, drying, improve meat tenderness, de-foaming
- Combination with another decontamination technology
  - Enhance bacteria reduction



- Necessary the presence of liquid phase
- Corrosion of surfaces due to cavitation
- Ultrasound alone is not very effective in bacteria inactivation
- Potential quality degradation
  - Protein and lipid oxidation
  - Cell Damage in certain foods

# Food technologies for food safety

- **Categories Based on Type of Energy or Physical Force:**
- **Acoustic-based technologies:**
  - Ultrasound (US)
  - **Hydrodynamic Cavitation (HC)**
    - Definitions & basic principles
    - Antimicrobial mechanism of action
    - Research evaluations
    - Industrial applications and research evaluations
    - Advantages/disadvantages

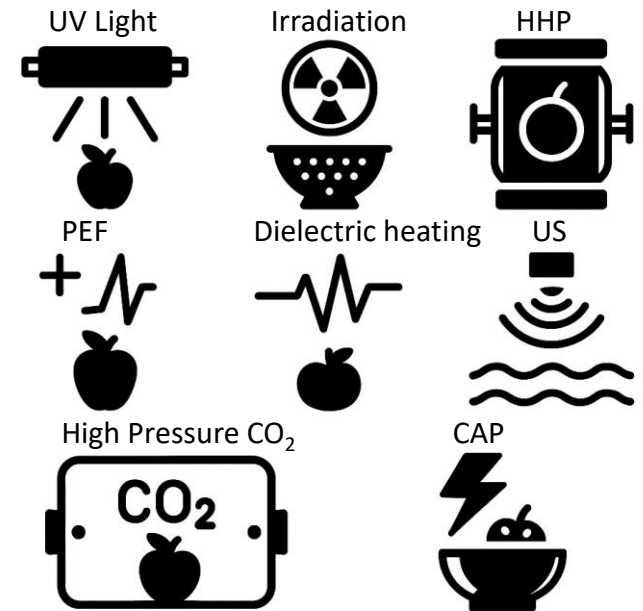

# Hydrostatic cavitation

## Definitions & basic principles

- Pressure variations within a flowing liquid

- Changes in velocity
- Key factor: system's geometry

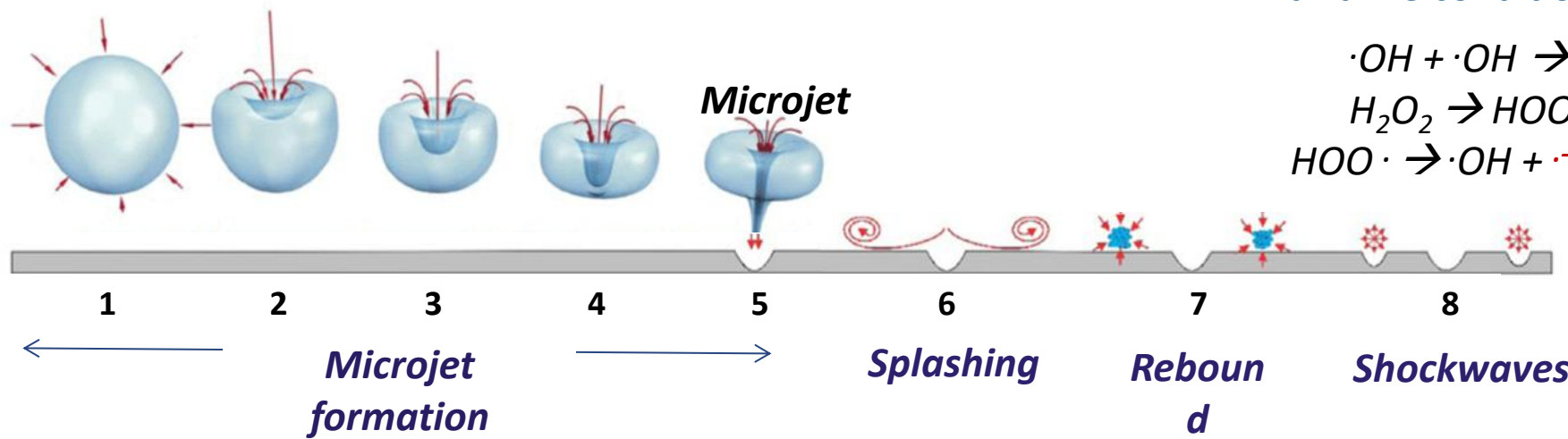
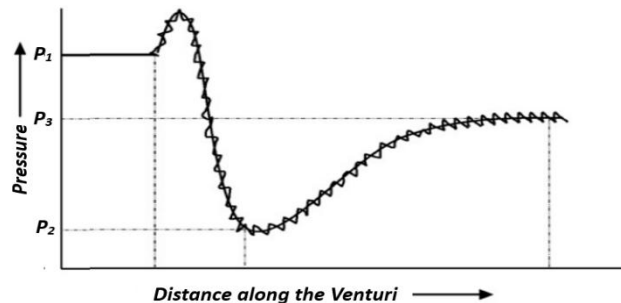

- Extreme pressures (500 atm)
- Local hotspots (1500 K)
- Homolytic cleavage of water molecules:

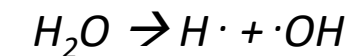

- Generation of radicals under alkaline conditions:

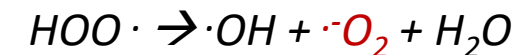

# Hydrostatic cavitation

## Definitions & basic principles

- Type of set-ups:
  - Stationary: straightforward passage of a liquid through a channel (centrifugal pumps) (A,B)
  - Rotating: mechanical rotation of an object within a liquid (C, D)

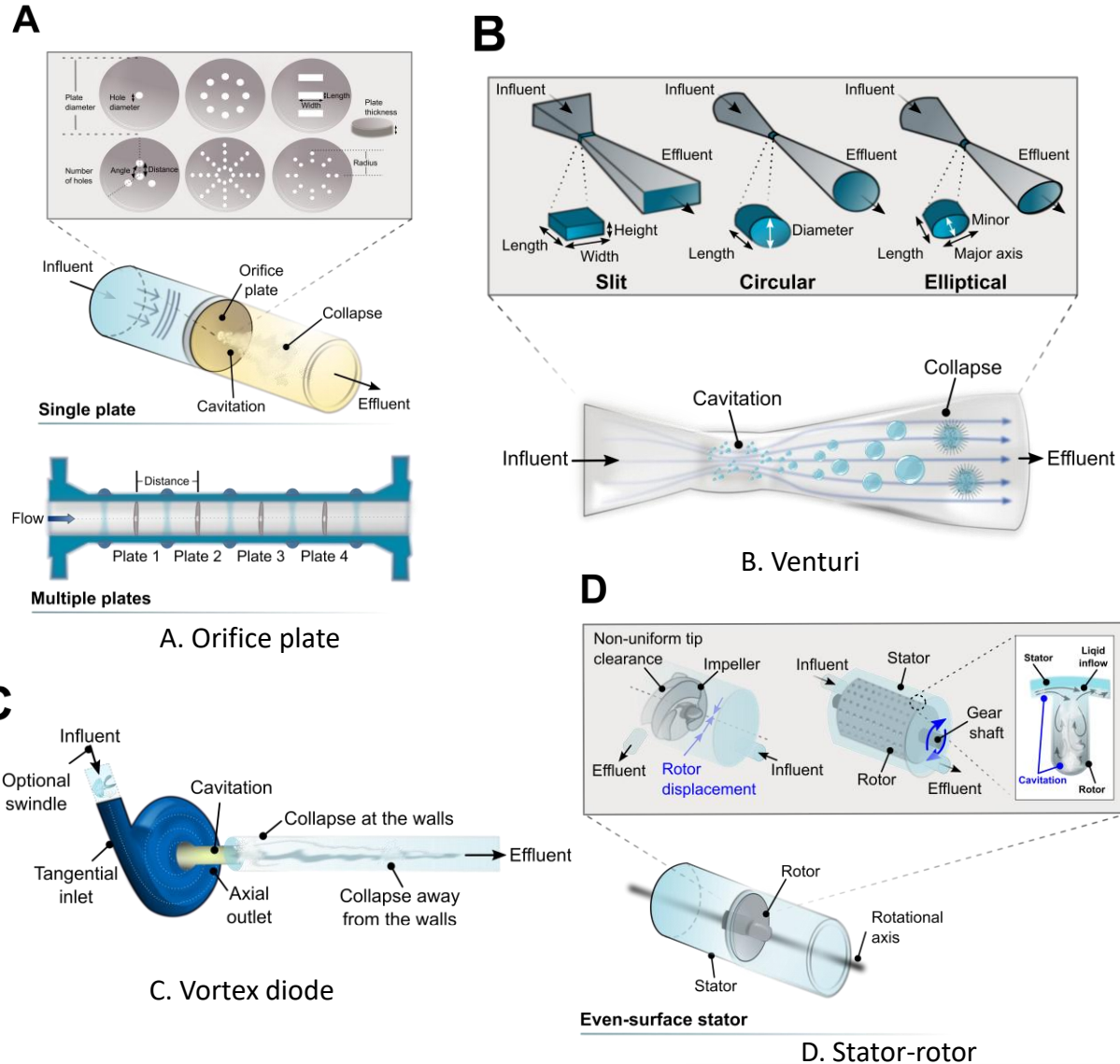

# Hydrostatic cavitation

Antimicrobial mechanism of action

Mechanical action

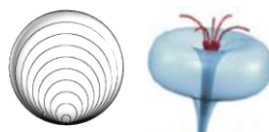

Shockwave  
6000 Gpa  
Microjets  
100 m s<sup>-1</sup>

Thermal effect

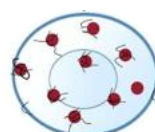

Hotspots

Chemical effect

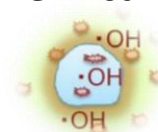

Reactive oxygen species  
(ROS)

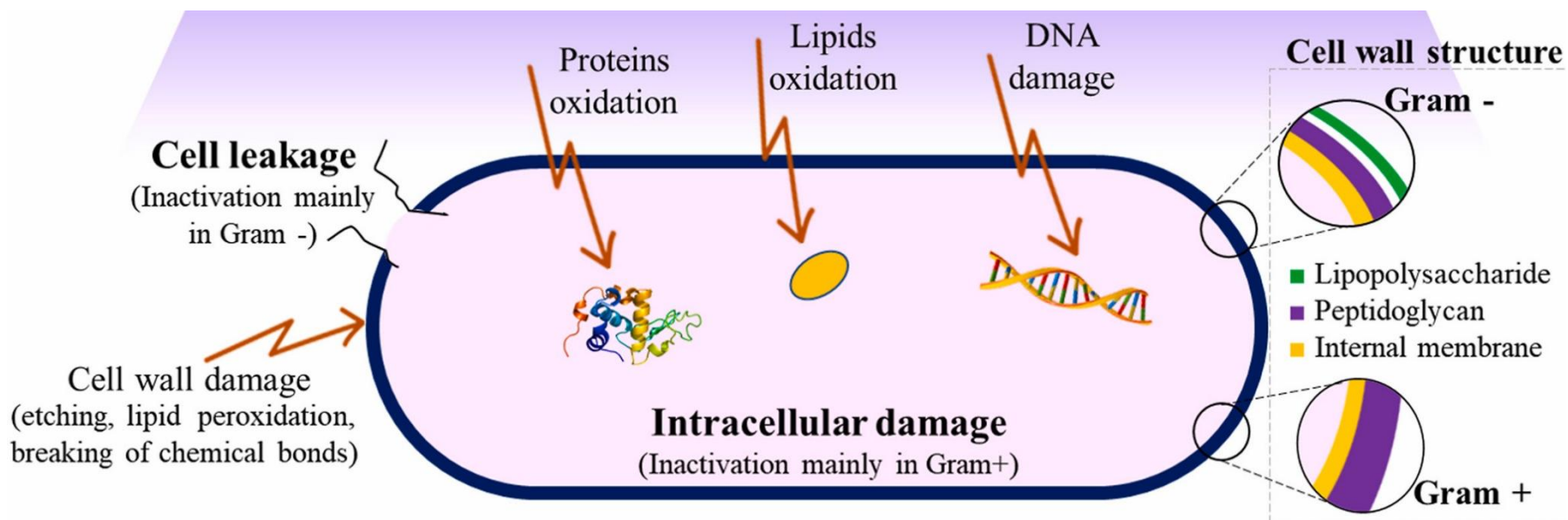

# Hydrostatic cavitation

## Research evaluations

- Case study 1: Hydrodynamic cavitation (HC) of skim milk concentrate
  - Problem statement

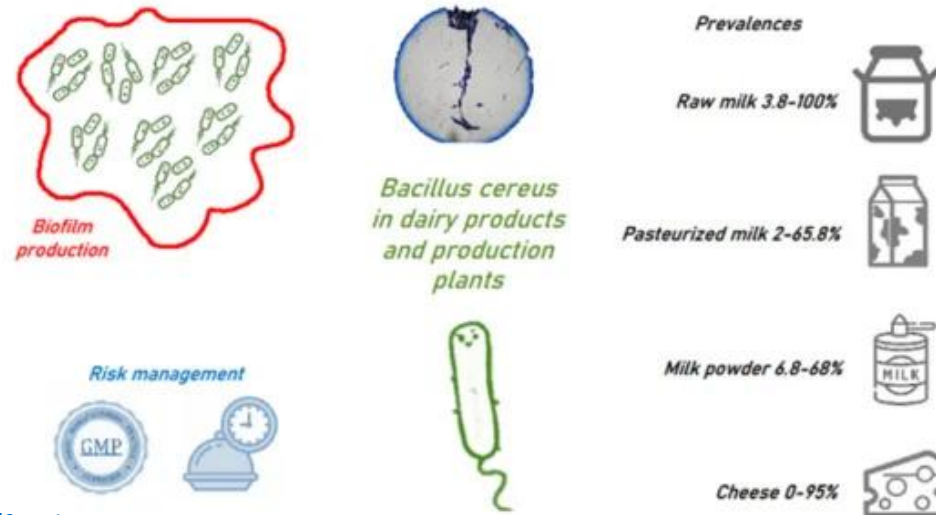

<https://doi.org/10.3390/foods11172572>

- Solution: application of HC to skin milk concentrate

# Hydrostatic cavitation

## Research evaluations

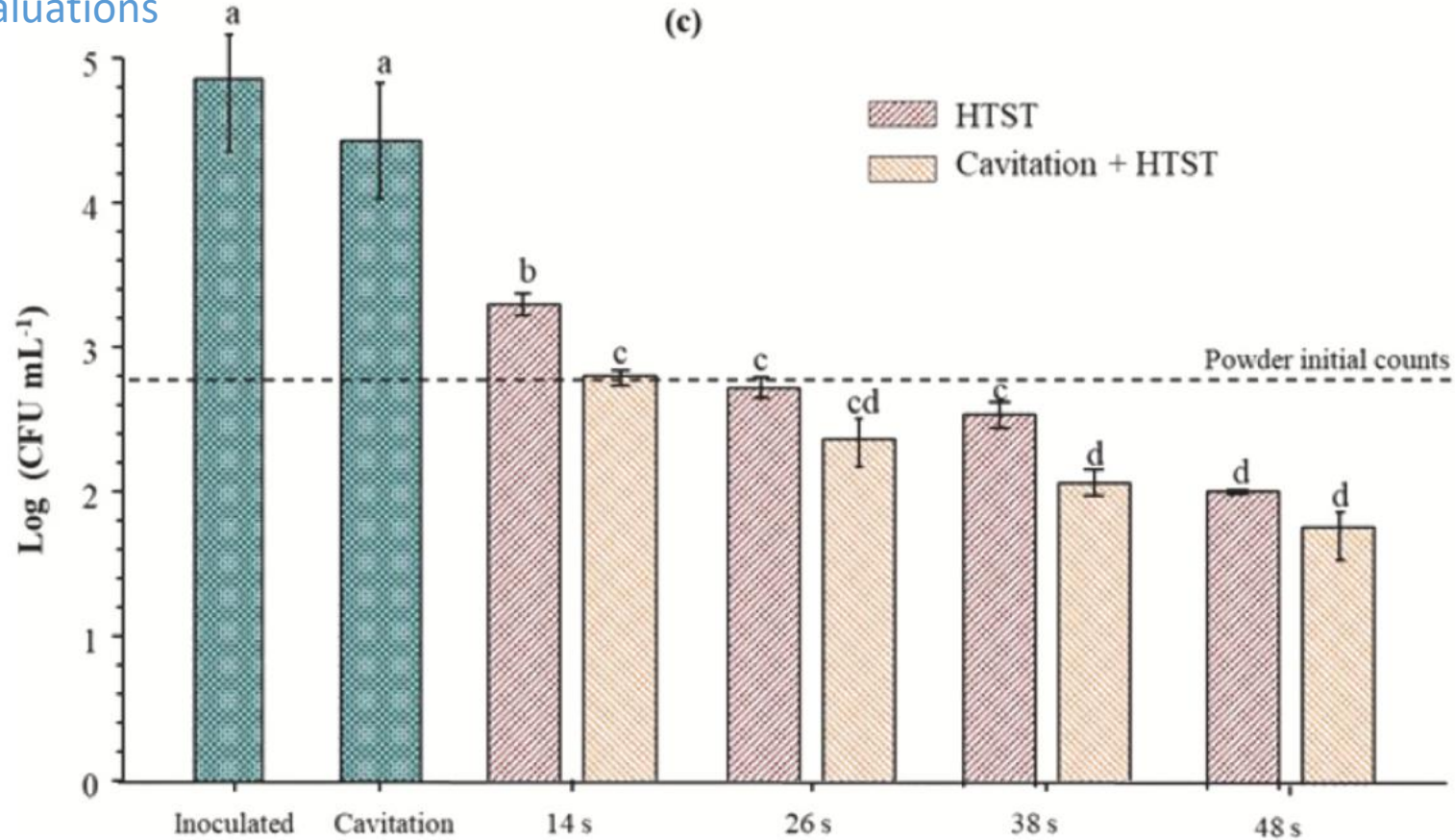

Survival of *B. coagulans* (ACCT 12245) in skim milk concentrate (34–36% total solids) at different points within the experimental rig: after inoculation (feeding tank), after cavitation (3600 RPM), and at 85°C. The entire process was performed at 100 L h<sup>-1</sup>. The discontinuous line represents the initial microbial load of the powder. Mean ± standard deviation within each column with different letters (a–e) are significantly different ( $p < 0.05$ ) according to Tukey test (<https://doi.org/10.1016/j.jfoodeng.2020.110382>).

# Hydrostatic cavitation

## Industrial applications

Hydrodynamic cavitator is applied for mixing:

- Solids in liquid: a controlled particle size reduction due to disintegration occurs during the treatment, increasing solids solubilization or dispersion in the liquid medium
- Gas in liquid: dispersion of microbubbles of  $N_2$  and  $CO_2$  in beer or beverages
- Liquid in liquid



Enhancing taste and texture of some mousse soups and yogurt and/or to increase product shelf life). Promoting the generation of uniform and homogeneous suspensions or dispersions

# Hydrostatic cavitation

## Advantages/disadvantages



- Enhanced Extraction Efficiency
- Improved Emulsification and Homogenization
- Microbial Inactivation & Food Safety
- Energy and Cost Efficiency
- Reduced Processing Time
- Minimized Thermal Damage



- Material Degradation
- Equipment Wear and Tear
- Limited Scalability
- Uncontrolled Radical Formation
- Need for Process Optimization

# Overview

	Cell	Enzyme	Solids	Liquids	Packaging	Surface
Irradiation	+		+	+	+	
Microwaves	+	+	+	+	+	
Ohmic heating	+	+	+	+		
UV Light	+		+	+	+	+
HHP	+	+/-	+	+	+	
PEF	+	+/-		+		
Ultrasound	+	+/-	+	+	+/-	
Ozone	+	+/-	+	+		+
CO <sub>2</sub>	+	+	-	+	-	-
Plasma	+	+/-	+	+	+	+
Hydrodynamic cavitation	+	+/-	-	+	-	-