

# Towards Thermal Performance:

## Di-*n*-Alkyl Adipates for Efficient Low-Temperature Thermal Energy Storage

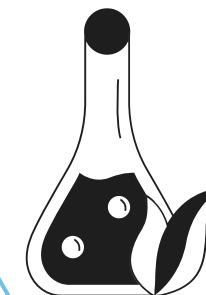
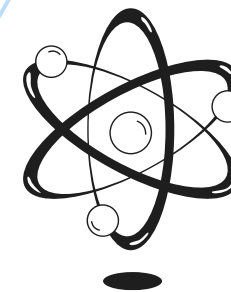

Maria C. M. Sequeira, Bernardo A. Nogueira, Timur Nikitin, Fernando J. P. Caetano, Hermínio A. P. Diogo, João M. N. A. Fareleira, Rui Fausto

**Thermal Energy  
Storage (TES)**



**Energy Efficiency**

**Supply-Demand  
Balance**



## **Thermal Energy Storage (TES)**



**Energy Efficiency**

**Supply-Demand Balance**



## **Phase Change Materials (PCM)**



**Latent Heat vs Sensible Heat**

**High energy storage capacity**

**Reversible transitions**

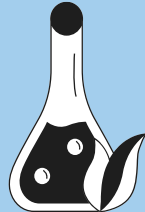

## **Thermal Energy Storage (TES)**



**Energy Efficiency**

**Supply-Demand Balance**



## **Phase Change Materials (PCM)**



**Latent Heat vs Sensible Heat**

**High energy storage capacity**

**Reversible transitions**

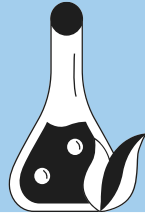

## **Low - T Applications**



**Cryogenic cooling**

**Storage and Transportaion of medicines**

**Pharmaceuticals**

**Cold Chain Logistics**



## **Thermal Energy Storage (TES)**



**Energy Efficiency**

**Supply-Demand Balance**



## **Phase Change Materials (PCM)**



**Latent Heat vs Sensible Heat**

**High energy storage capacity**

**Reversible transitions**



## **Low - T Applications**



**Cryogenic cooling**

**Storage and Transportaion of medicines**

**Pharmaceuticals**

**Cold Chain Logistics**



## **Designing PCM**



**Lack of available data for low - T**

**Costumized characteristics**

**Reliable and Efficient**

**Environmentally Safe**

**Cost-effective**

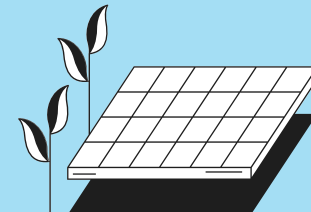

## Thermal Energy Storage (TES)



Energy Efficiency

Supply-Demand Balance



## Phase Change Materials (PCM)



Latent Heat vs Sensible Heat

High energy storage capacity

Reversible transitions



## Low - T Applications



Cryogenic cooling

Storage and Transportation of medicines

Pharmaceuticals

Cold Chain Logistics



## Designing PCM



Lack of available data for low - T

Customized characteristics

Reliable and Efficient

Environmentally Safe

Cost-effective

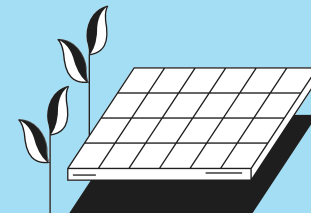

## Research Work



Design new PCM for low - T applications

Binary systems with customized properties

Solid-Liquid Phase Diagrams

*n*-alkyl adipates

Promising candidates as PCM



# Phase Equilibrium Studies

## Towards Thermal Performance



Thermal  
Energy  
Storage  
Design

# Optimizing Energy Storage

- Understanding Temperatures and enthalpies associated with phase changes
- Selection of materials to store/release energy efficiently

# Binary Phase Diagrams

## Optimizing Energy Storage

- Understanding Temperatures and enthalpies associated with phase changes
- Selection of materials to store/release energy efficiently

## Enhancing Material Stability

Ensures that PCMs maintain consistent performance over many thermal cycles, avoiding degradation or phase separation

# Binary Phase Diagrams

## Optimizing Energy Storage

- Understanding Temperatures and enthalpies associated with phase changes
- Selection of materials to store/release energy efficiently

## Enhancing Material Stability

Ensures that PCMs maintain consistent performance over many thermal cycles, avoiding degradation or phase separation

# Binary Phase Diagrams

## Designing Efficient Systems

Helps in designing TES systems with optimal heat transfer characteristics, reducing energy losses and improving overall efficiency.

## Optimizing Energy Storage

- Understanding Temperatures and enthalpies associated with phase changes
- Selection of materials to store/release energy efficiently

## Enhancing Material Stability

Ensures that PCMs maintain consistent performance over many thermal cycles, avoiding degradation or phase separation

# Binary Phase Diagrams

## Designing Efficient Systems

Helps in designing TES systems with optimal heat transfer characteristics, reducing energy losses and improving overall efficiency.

## Economic and Environmental Benefits

Development of cost-effective and environmentally friendly energy storage solutions by optimizing material usage and reducing waste.

# Experimental Design of Binary Phase Diagrams



# Differential Scanning Calorimetry (DSC)

Thermal Analysis

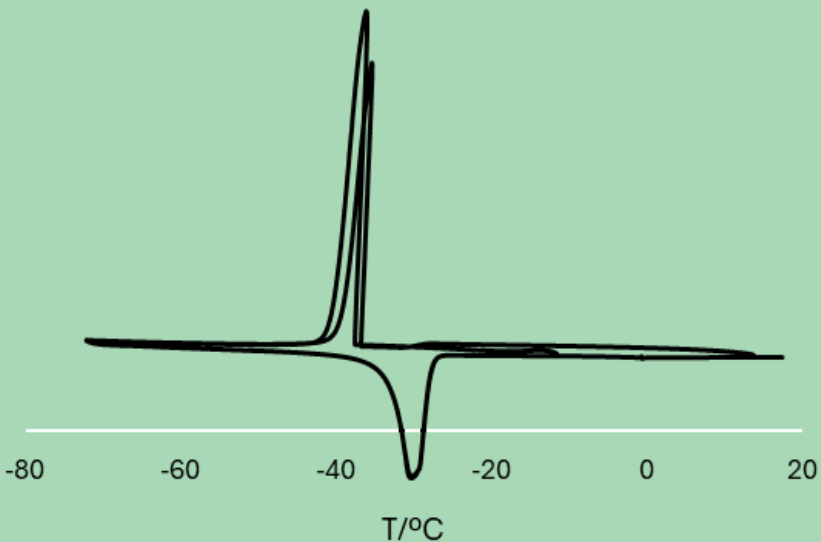

**Temperature** and **enthalpy** of phase transition

# Hot-Stage Polarized Microscopy (HSPM)

Microscopic Analysis

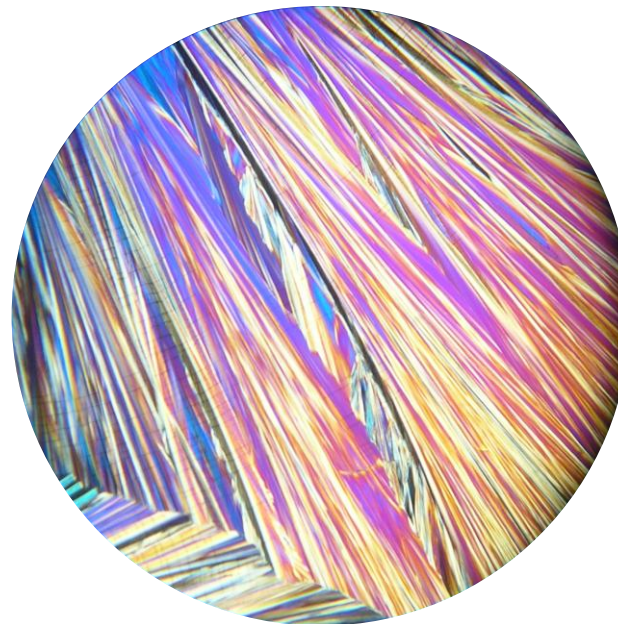

Real-time **visual evidence** of **thermal events**

# Raman Spectroscopy

Spectroscopic Analysis

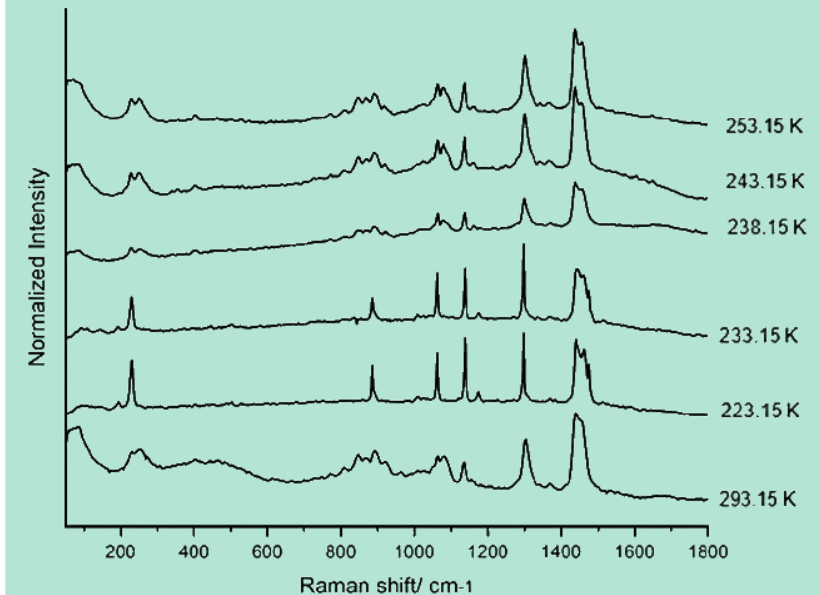

**Identification** and **characterization** of the **thermal events**

# Hot Stage Polarized Microscopy

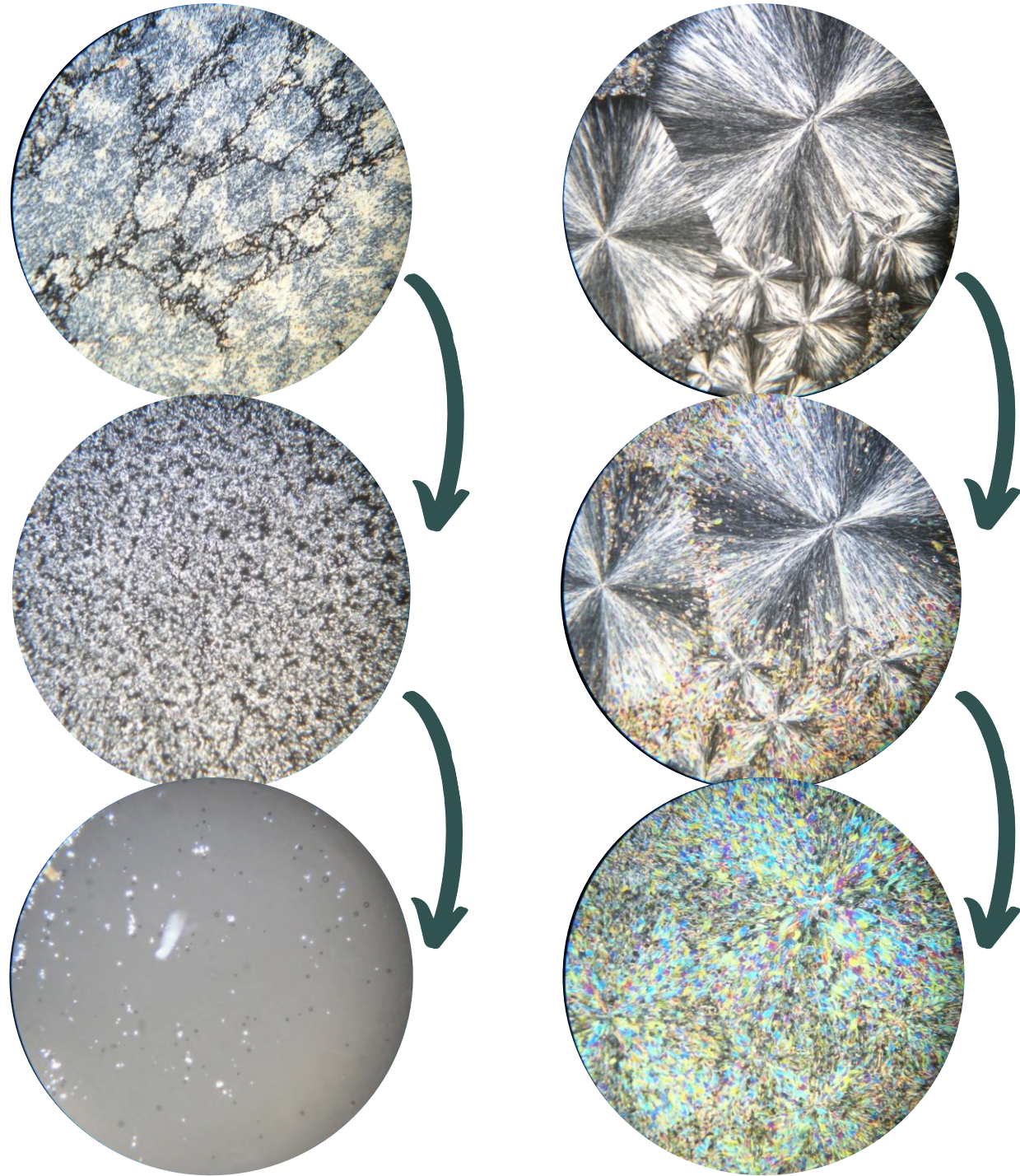

# Raman Spectroscopy

## 1<sup>st</sup> Step: Pure compounds

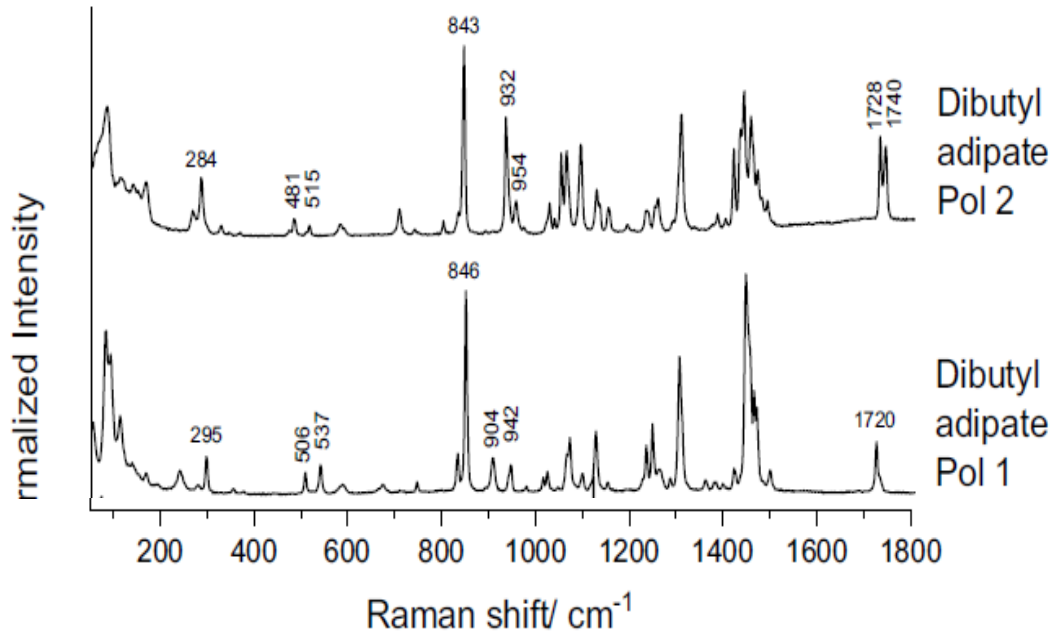

## 2<sup>nd</sup> Step: Binary mixtures

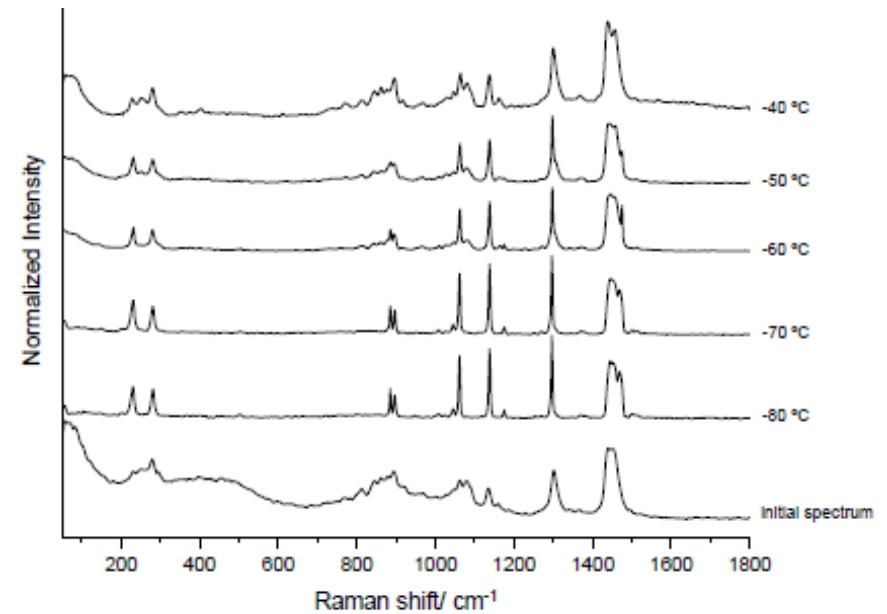



# Di-*n*-Alkyl Adipates

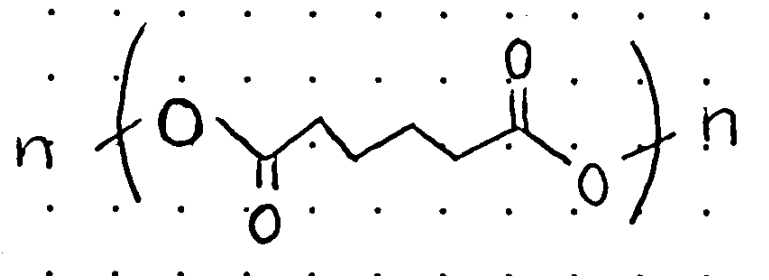

# Studied Binary Systems

**Diethyl (DEA)  
+  
Dibutyl (DBA)**

# Studied Binary Systems

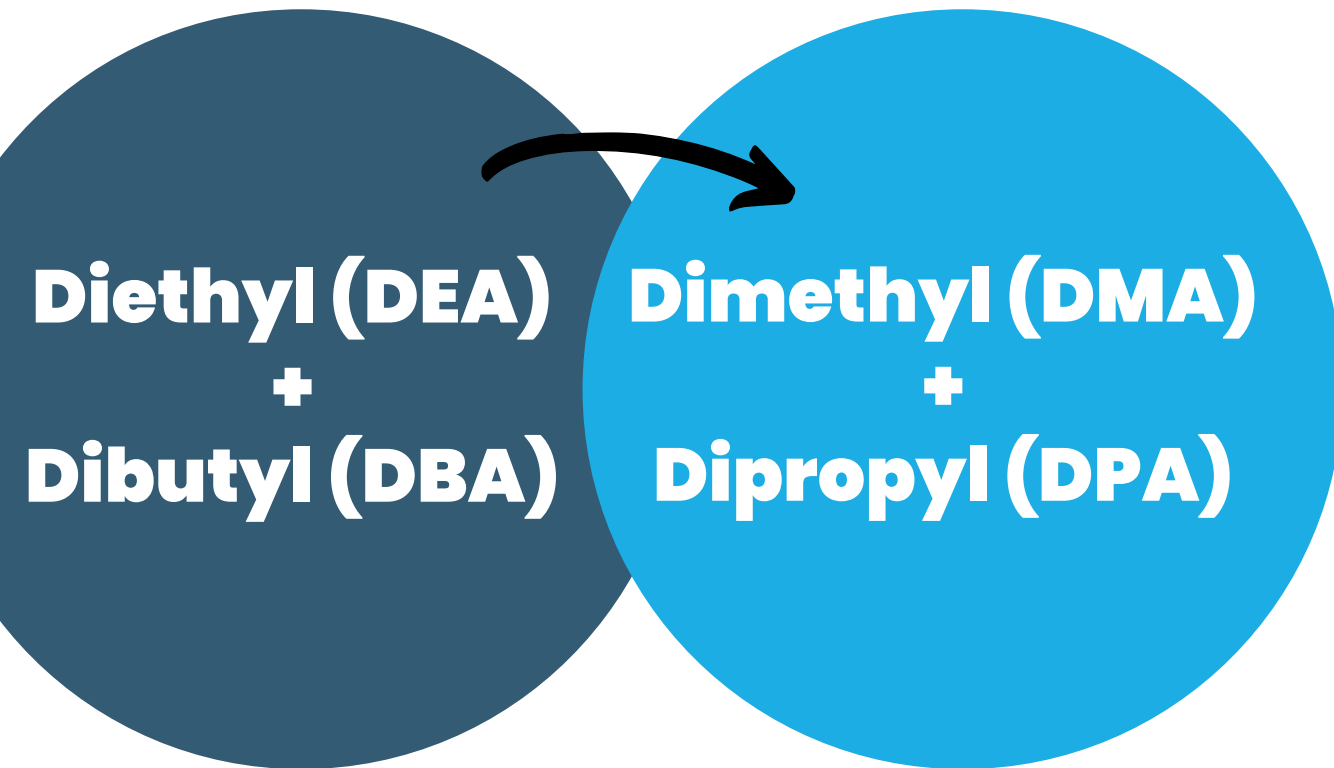

# Studied Binary Systems

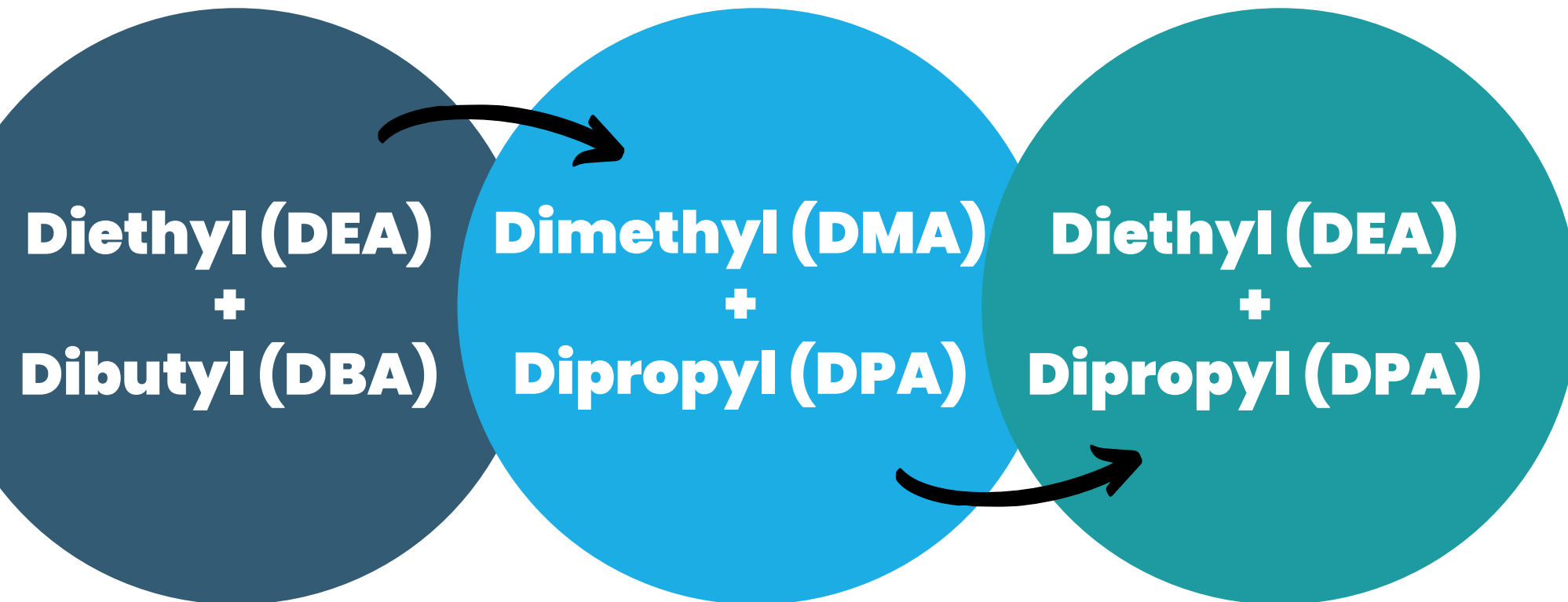

# Studied Binary Systems

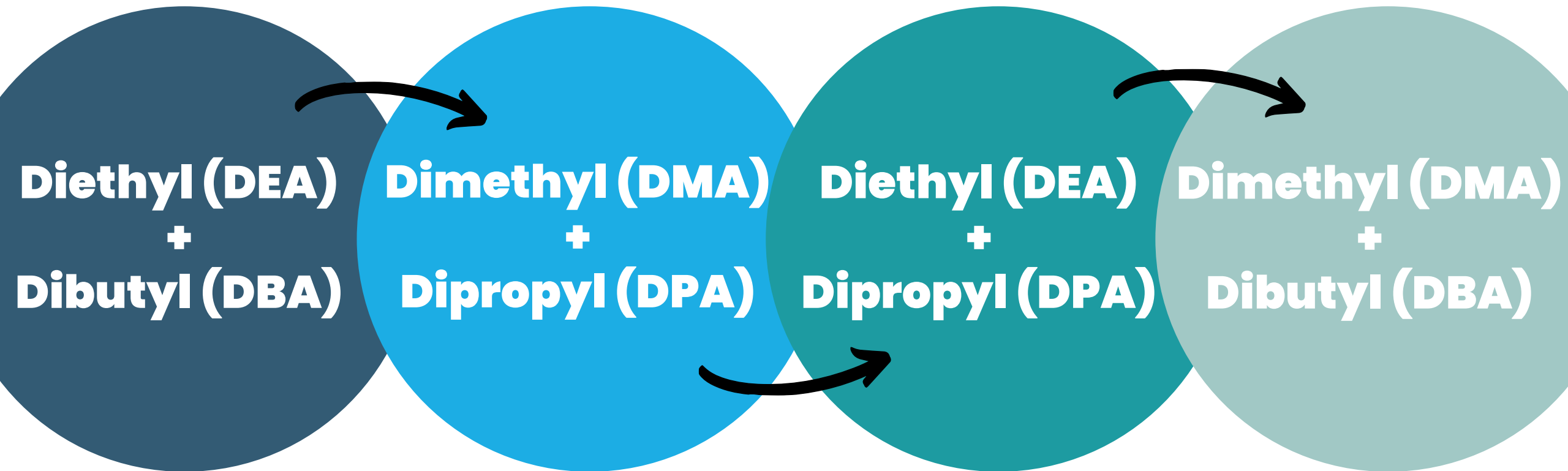

# 01 Binary system Diethyl + Dibutyl adipates

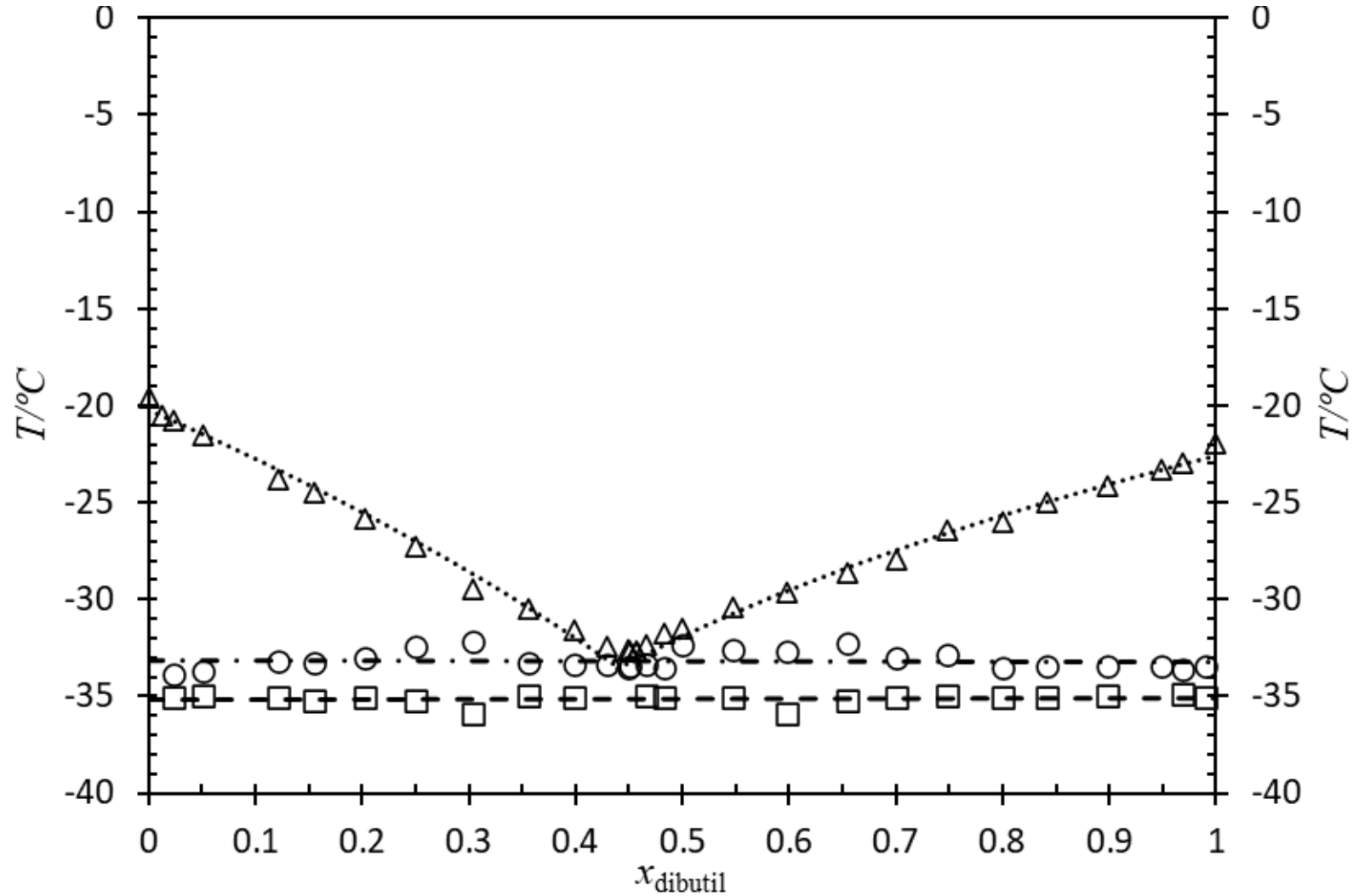
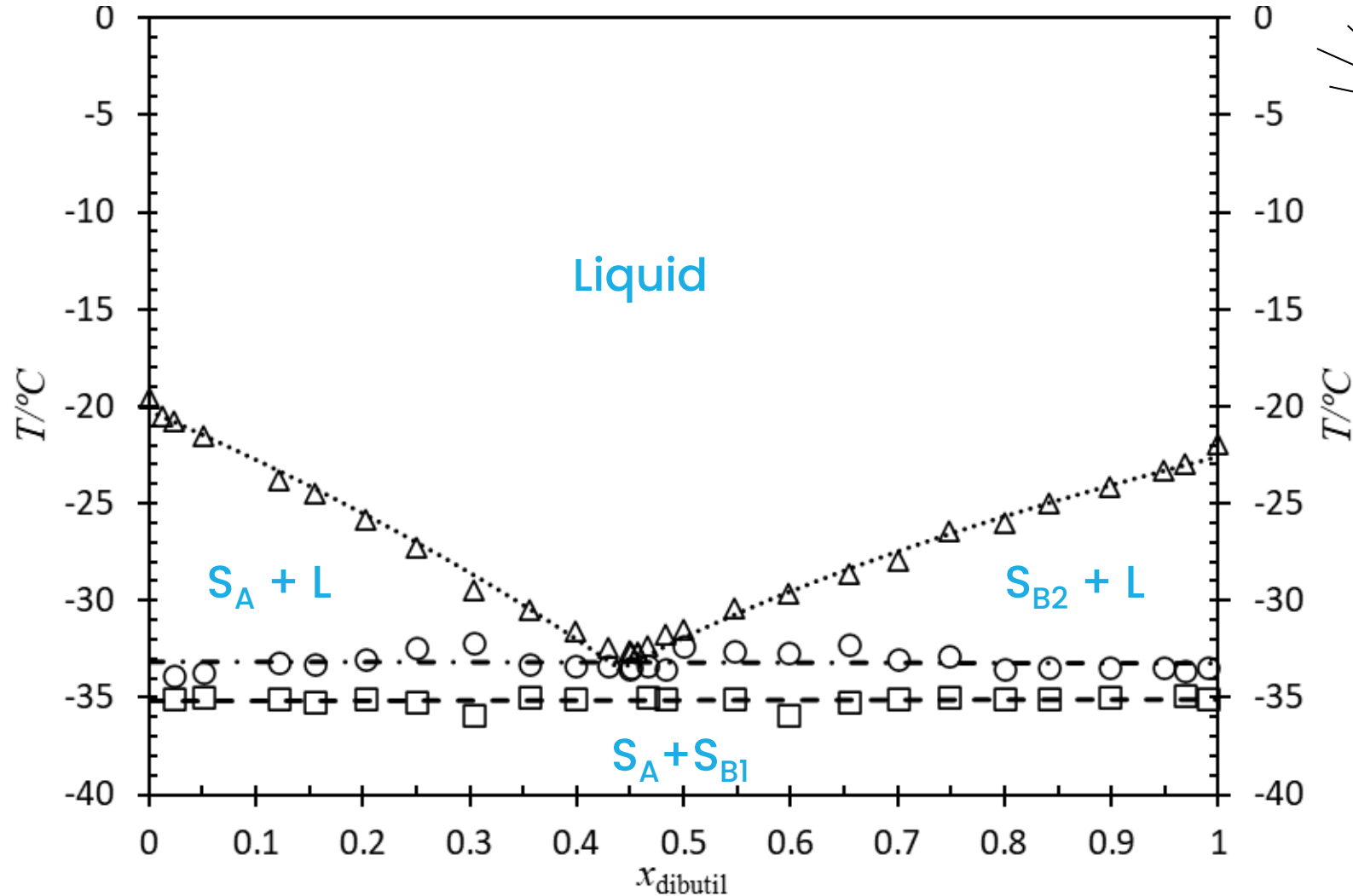

Fig. 1 Binary phase diagram for the adipate system Diethyl + Dibutyl. Published in the *International Journal of Thermophysics*.

# 01 Binary system Diethyl + Dibutyl adipates



Eutectic system

Fig. 1 Binary phase diagram for the adipate system Diethyl + Dibutyl. Published in the *International Journal of Thermophysics*.

# 01 Binary system Diethyl + Dibutyl adipates

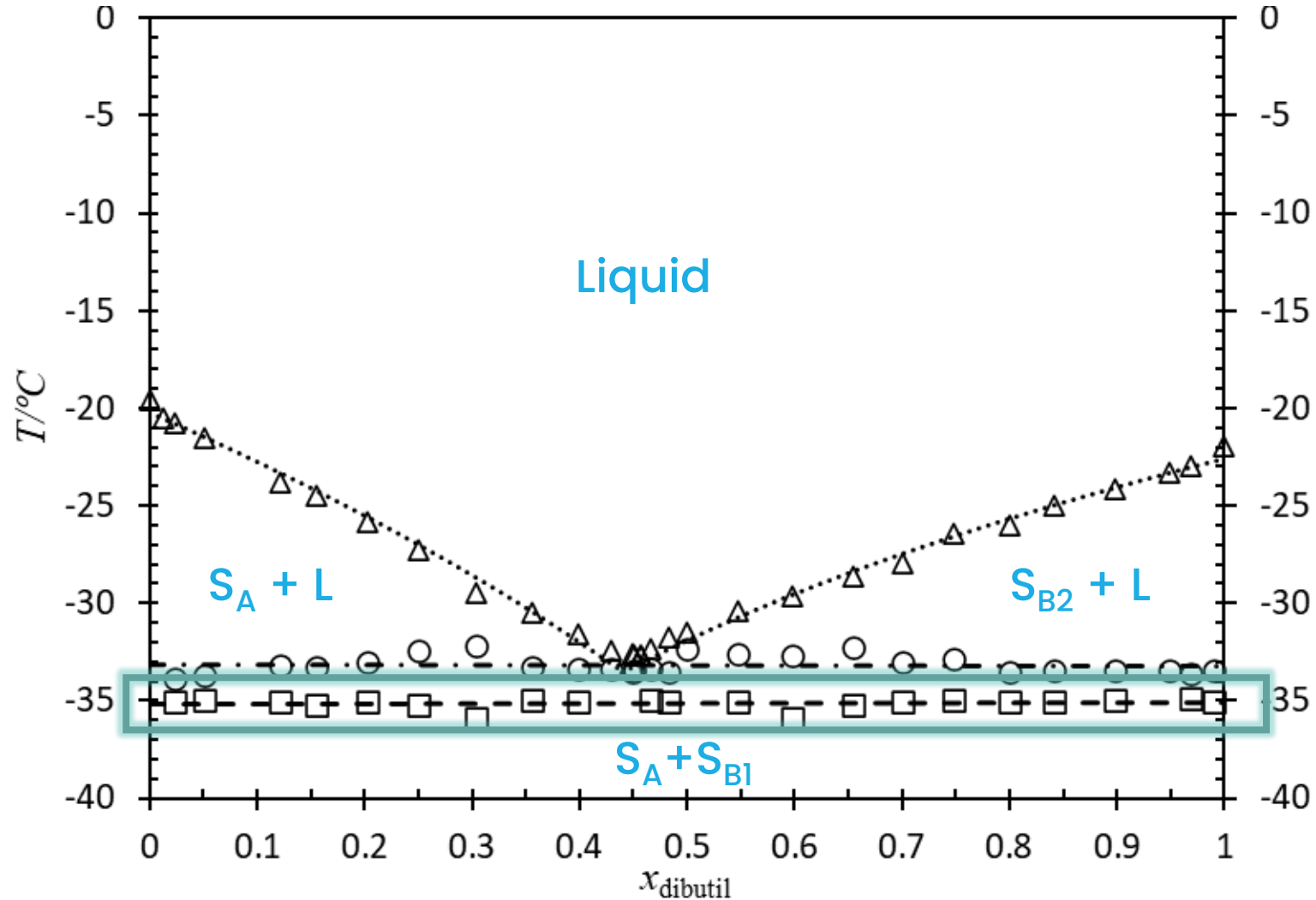

Eutectic system



Polymorphism

Fig. 1 Binary phase diagram for the adipate system Diethyl + Dibutyl. Published in the *International Journal of Thermophysics*.

# 01 Binary system Diethyl + Dibutyl adipates

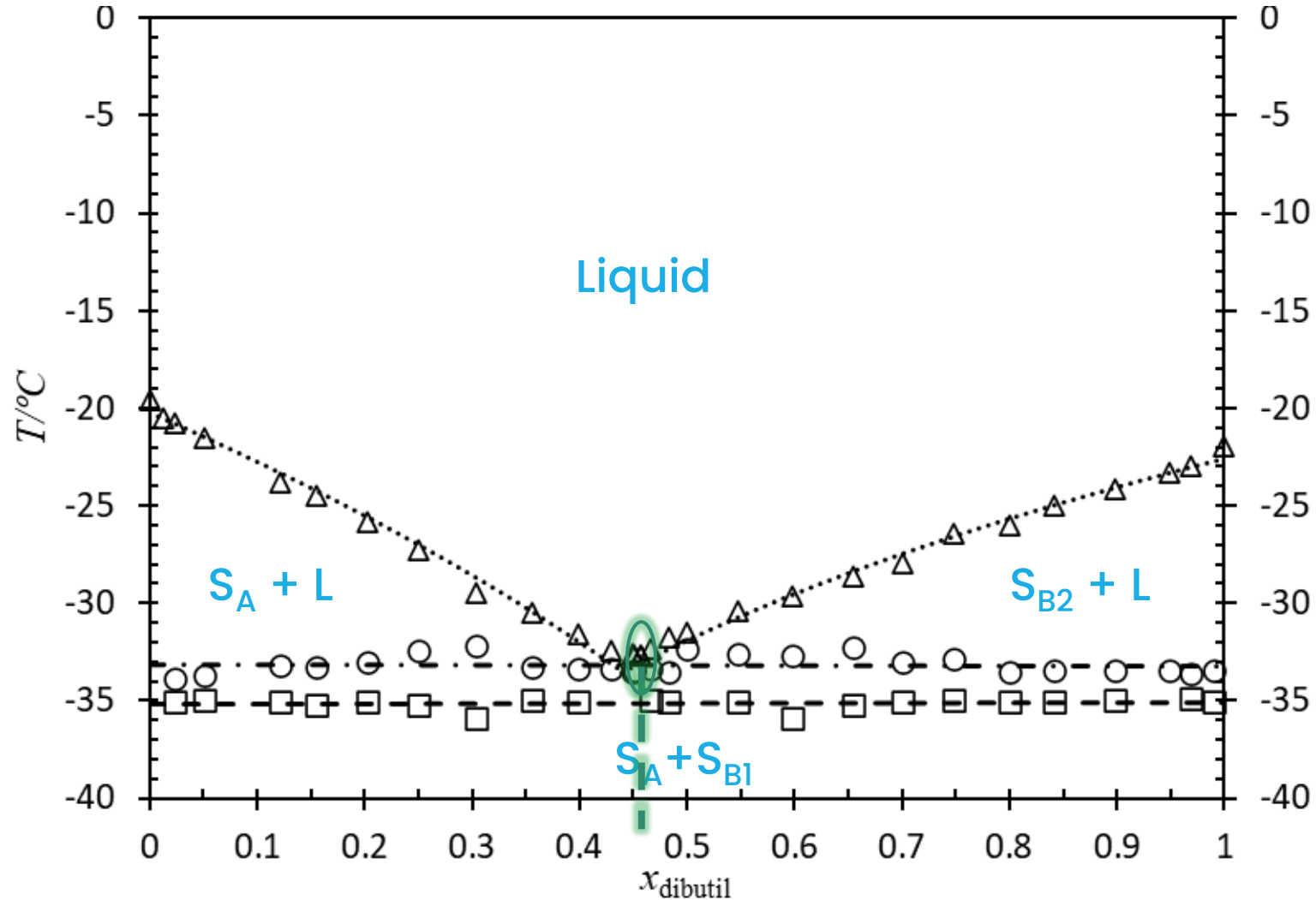

Eutectic system



Polymorphism



Eutectic composition:  $x_{\text{DBA}} = 0.46$

Fig. 1 Binary phase diagram for the adipate system Diethyl + Dibutyl. Published in the *International Journal of Thermophysics*.

# 01 Binary system Diethyl + Dibutyl adipates

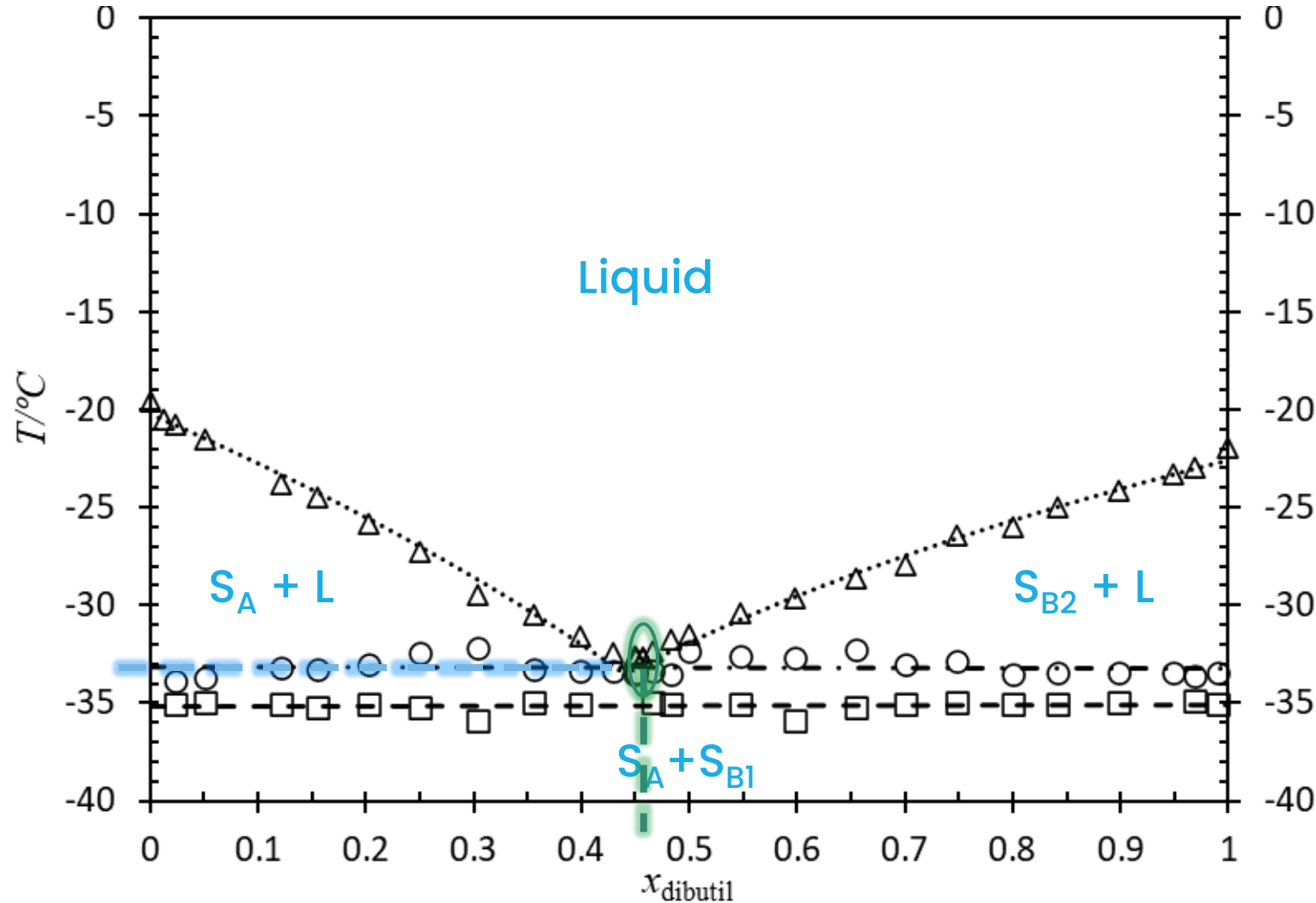

Eutectic system



Polymorphism



Eutectic composition:  $x_{\text{DBA}} = 0.46$

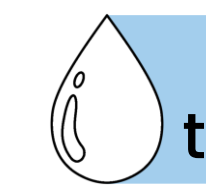

Eutectic temperature:  $-32.7^\circ\text{C}$

Fig. 1 Binary phase diagram for the adipate system Diethyl + Dibutyl. Published in the *International Journal of Thermophysics*.

# 01 Binary system Diethyl + Dibutyl adipates

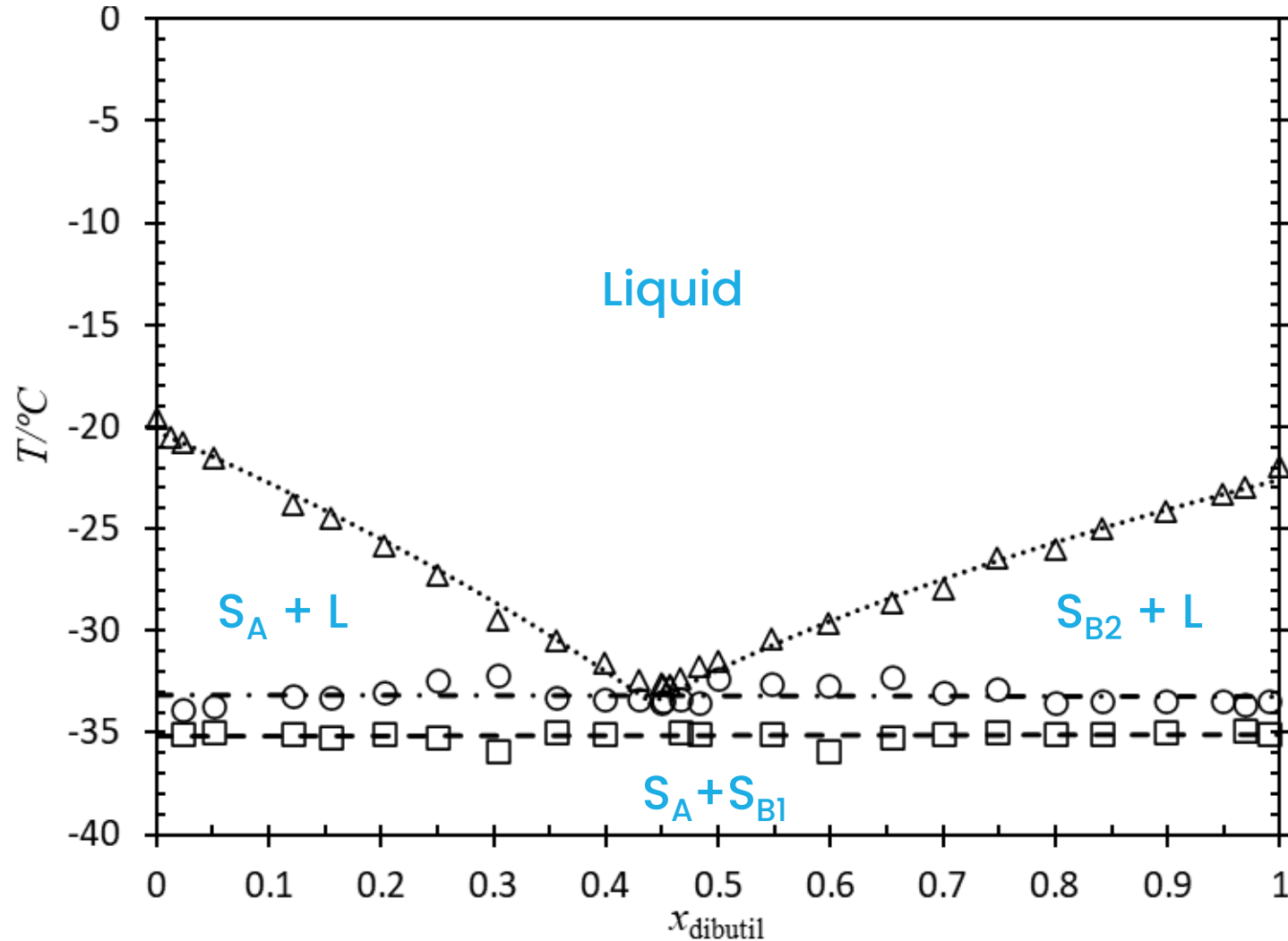

Fig. 1 Binary phase diagram for the adipate system Diethyl + Dibutyl. Published in the *International Journal of Thermophysics*.



Eutectic system



Polymorphism



Eutectic composition:  $x_{DBA} = 0.46$



Eutectic temperature:  $-32.7\text{ °C}$



Eutectic enthalpy:  $131.7\text{ J/g}$

02

# Binary system Dimethyl + Dipropyl adipates

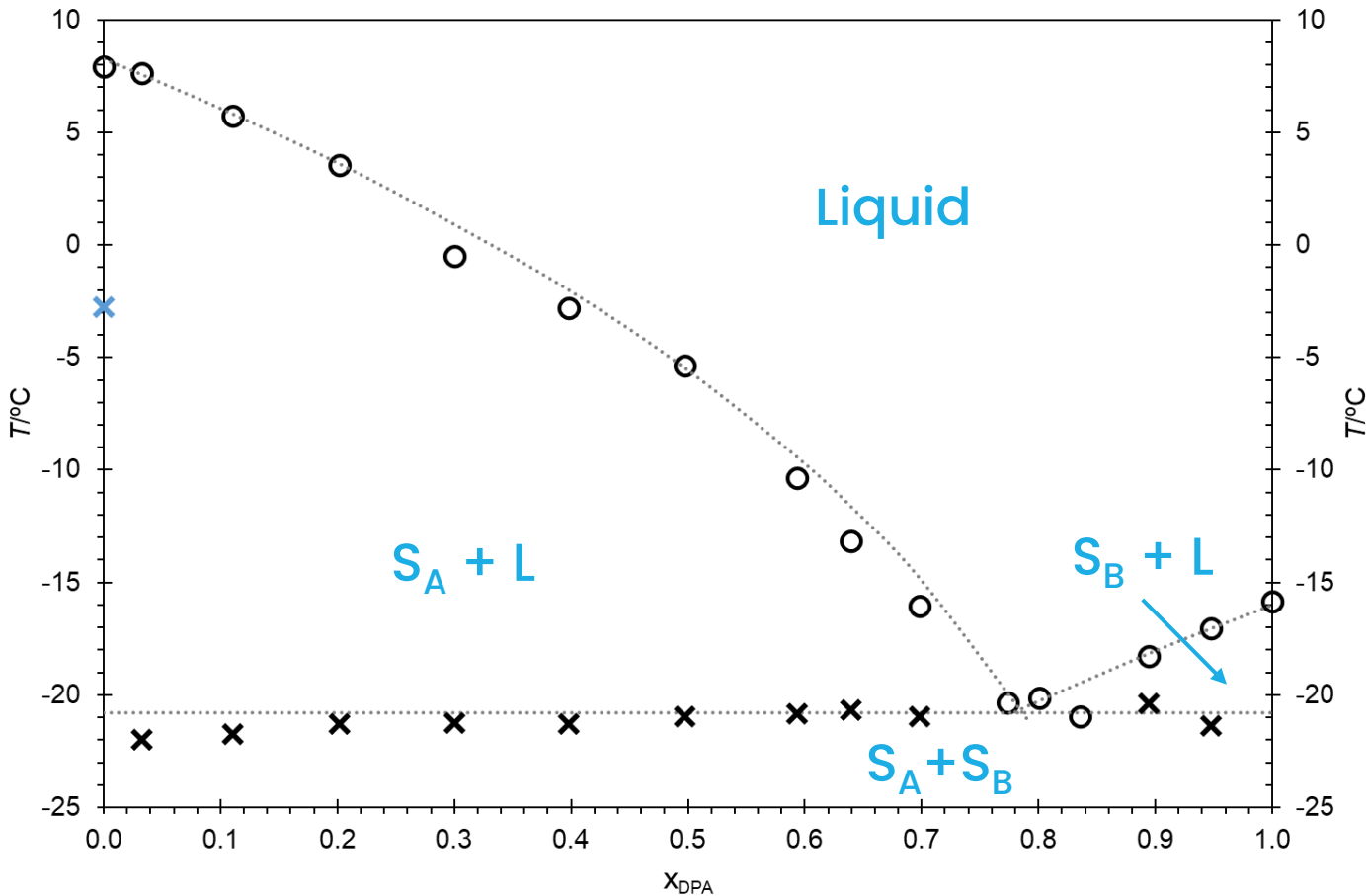

**Fig. 2** Binary phase diagram for the adipate system Dimethyl + Dipropyl. Published in the *International Journal of Thermophysics*.



Eutectic system



Eutectic composition:  $X_{DPA} = 0.77$



Eutectic temperature:  $-20.3\text{ }^\circ\text{C}$



Eutectic enthalpy:  $130.8\text{ J/g}$

# 03 Binary systems: DEA+DPA and DMA+DBA

## (Preliminary Results)

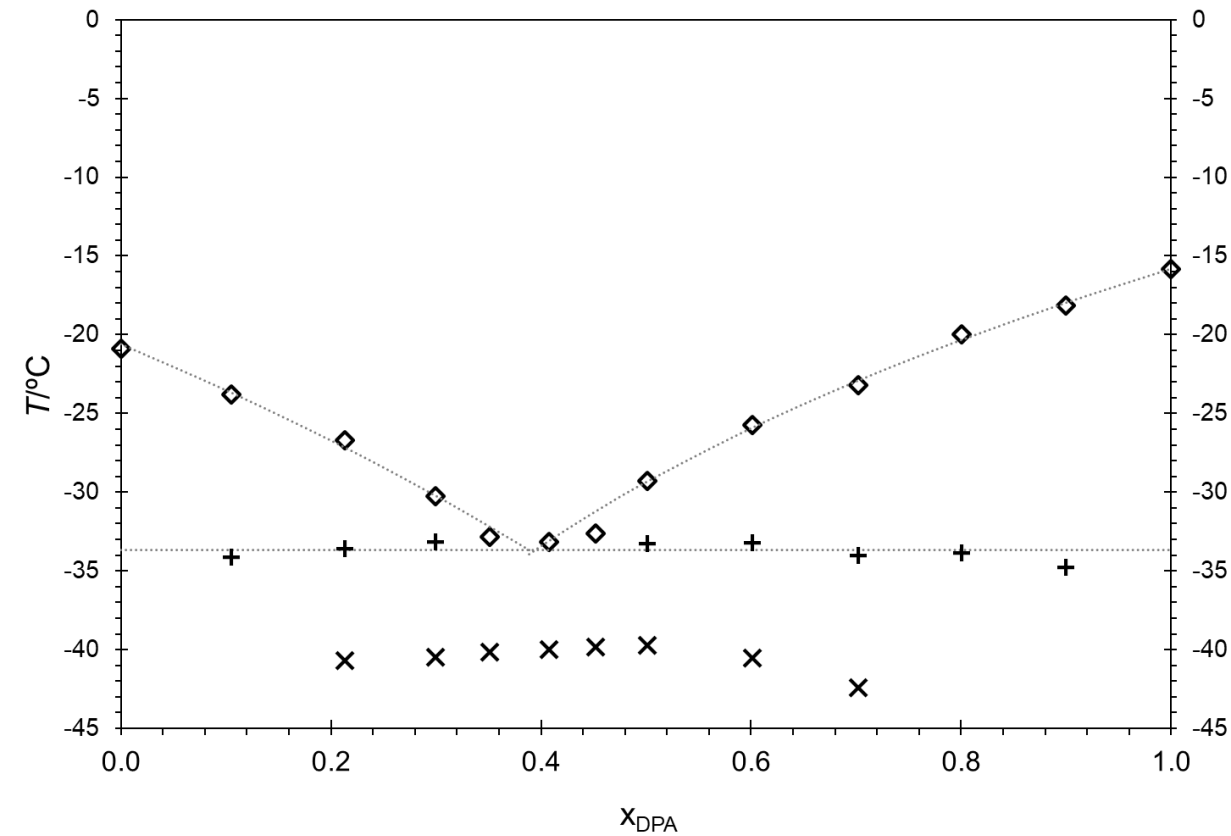

**Fig. 3** Preliminary binary phase diagram for the adipate system Diethyl + Dipropyl.

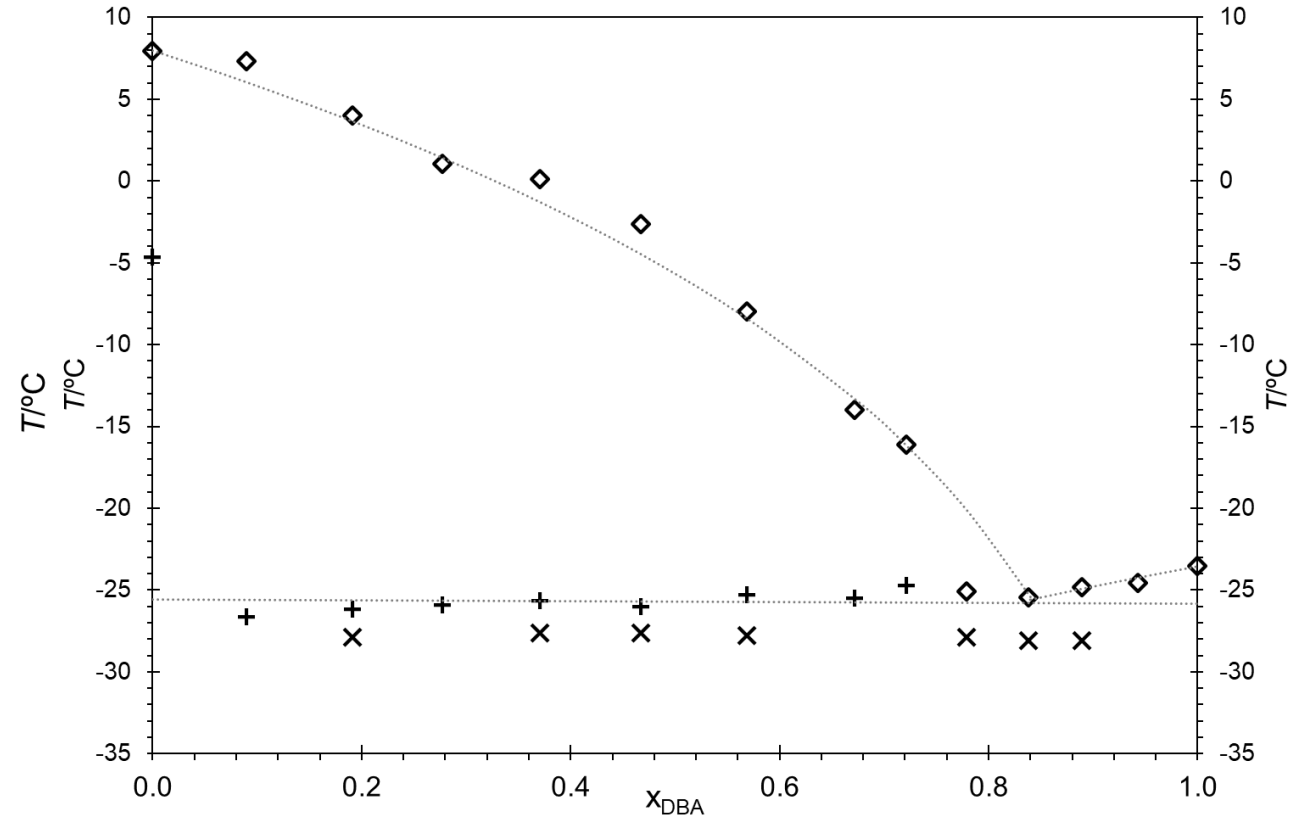

**Fig. 4** Preliminary binary phase diagram for the adipate system Dimethyl + Dibutyl.

# 03 Binary systems: DEA+DPA and DMA+DBA

## (Preliminary Results)

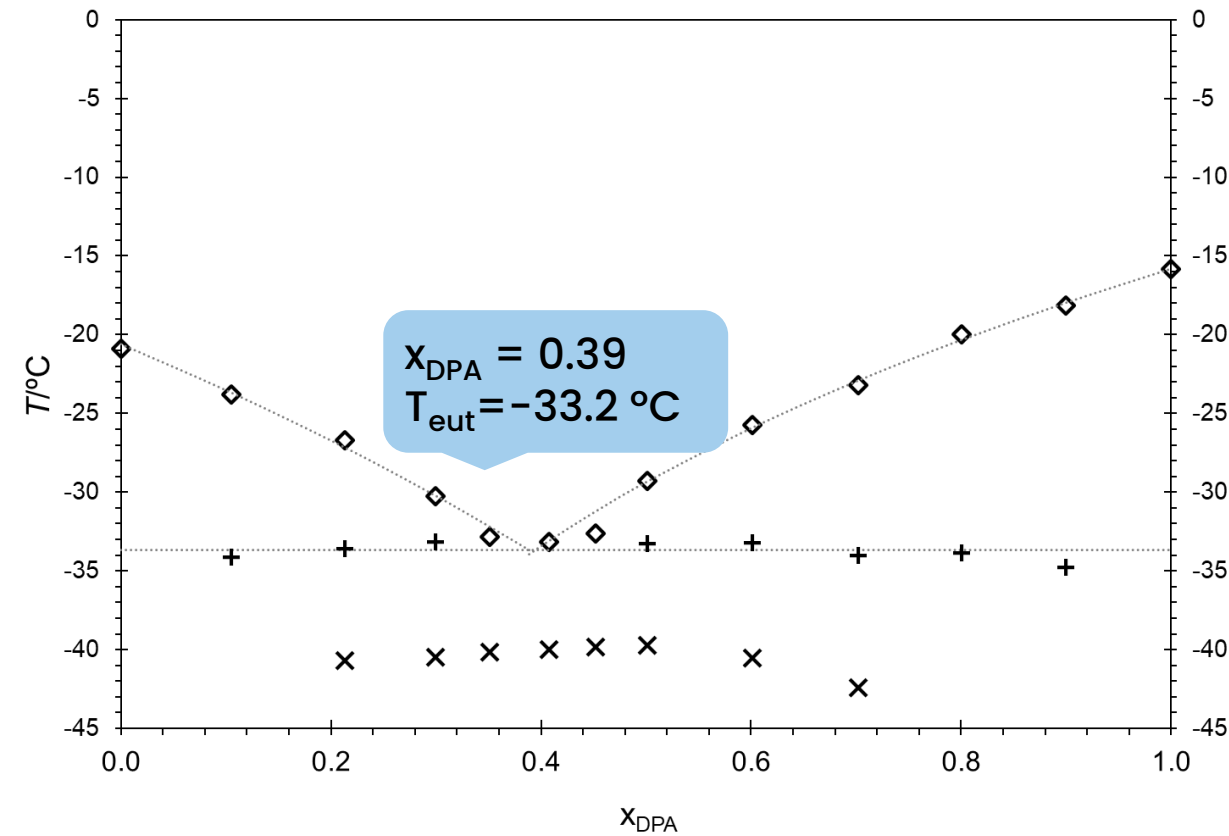

Fig. 3 Preliminary binary phase diagram for the adipate system Diethyl + Dipropyl.

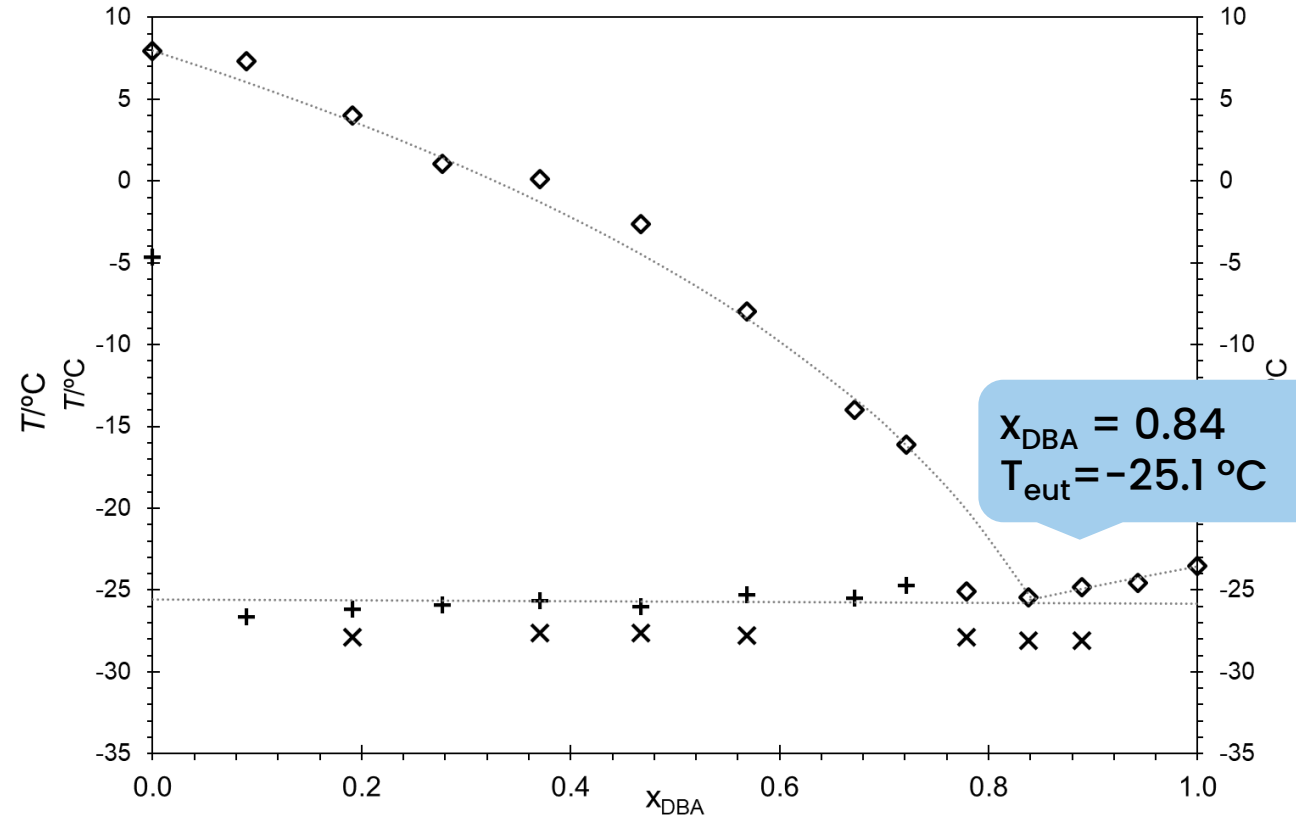
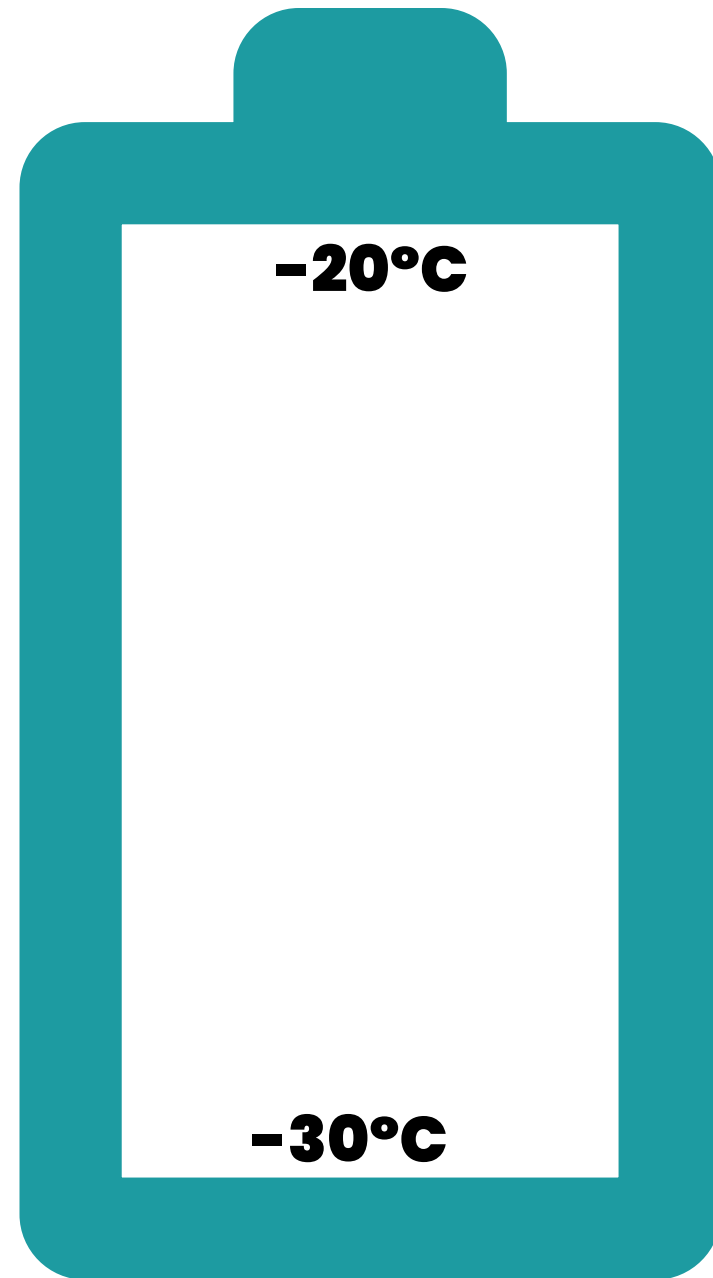
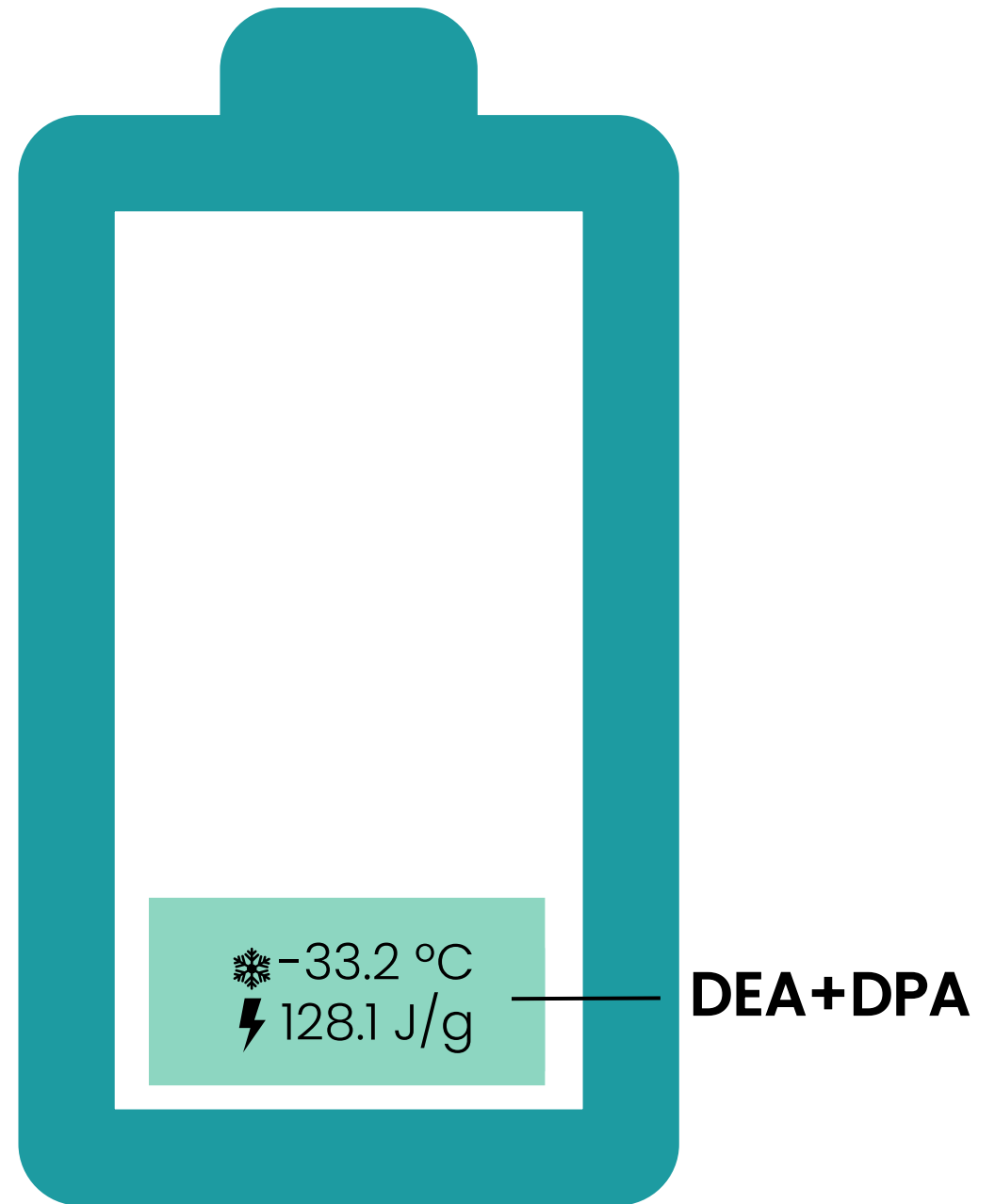

Fig. 4 Preliminary binary phase diagram for the adipate system Dimethyl + Dibutyl.

# Towards Cold Thermal Energy Storage



# Towards Cold Thermal Energy Storage



# Towards Cold Thermal Energy Storage

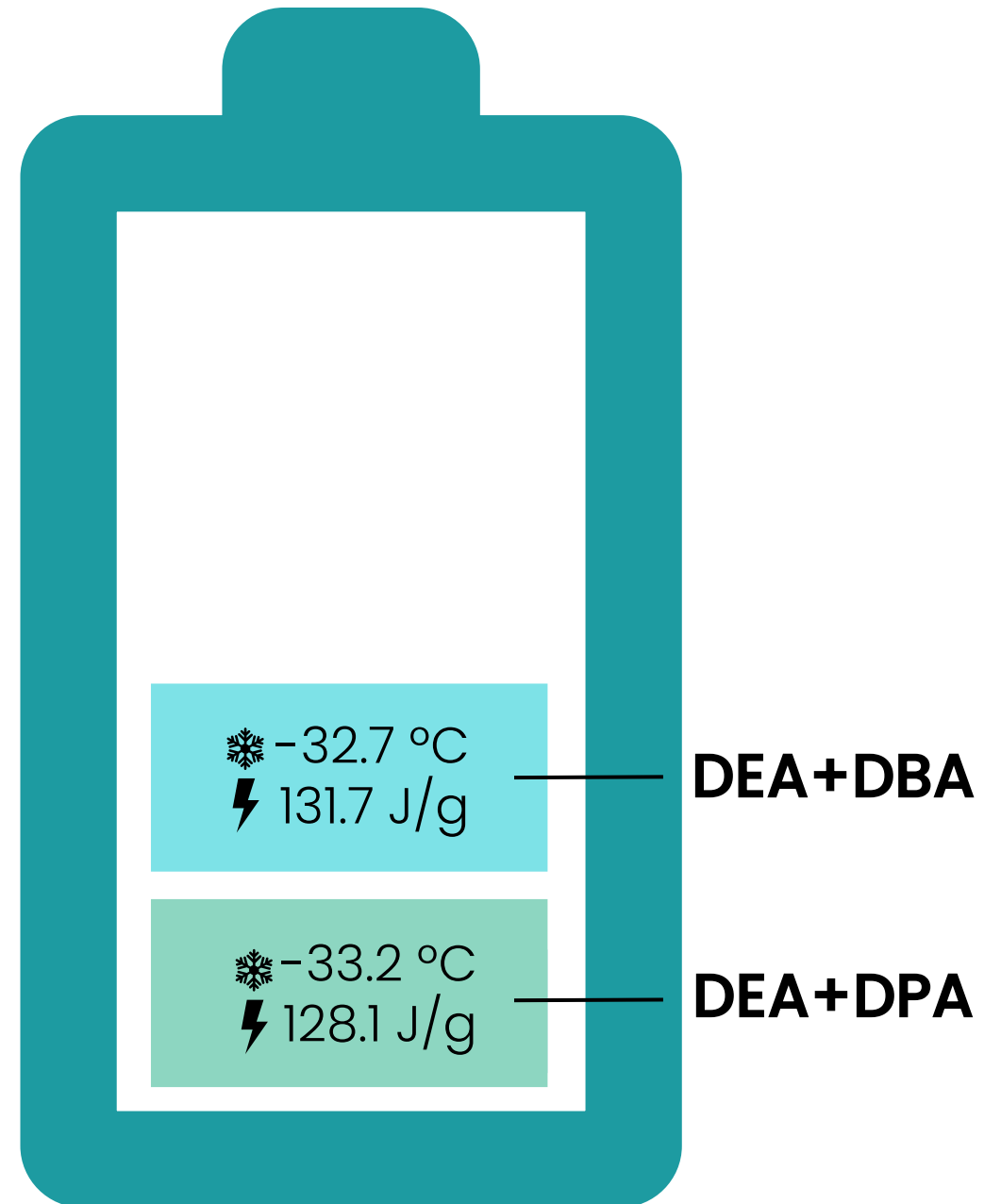

# Towards Cold Thermal Energy Storage

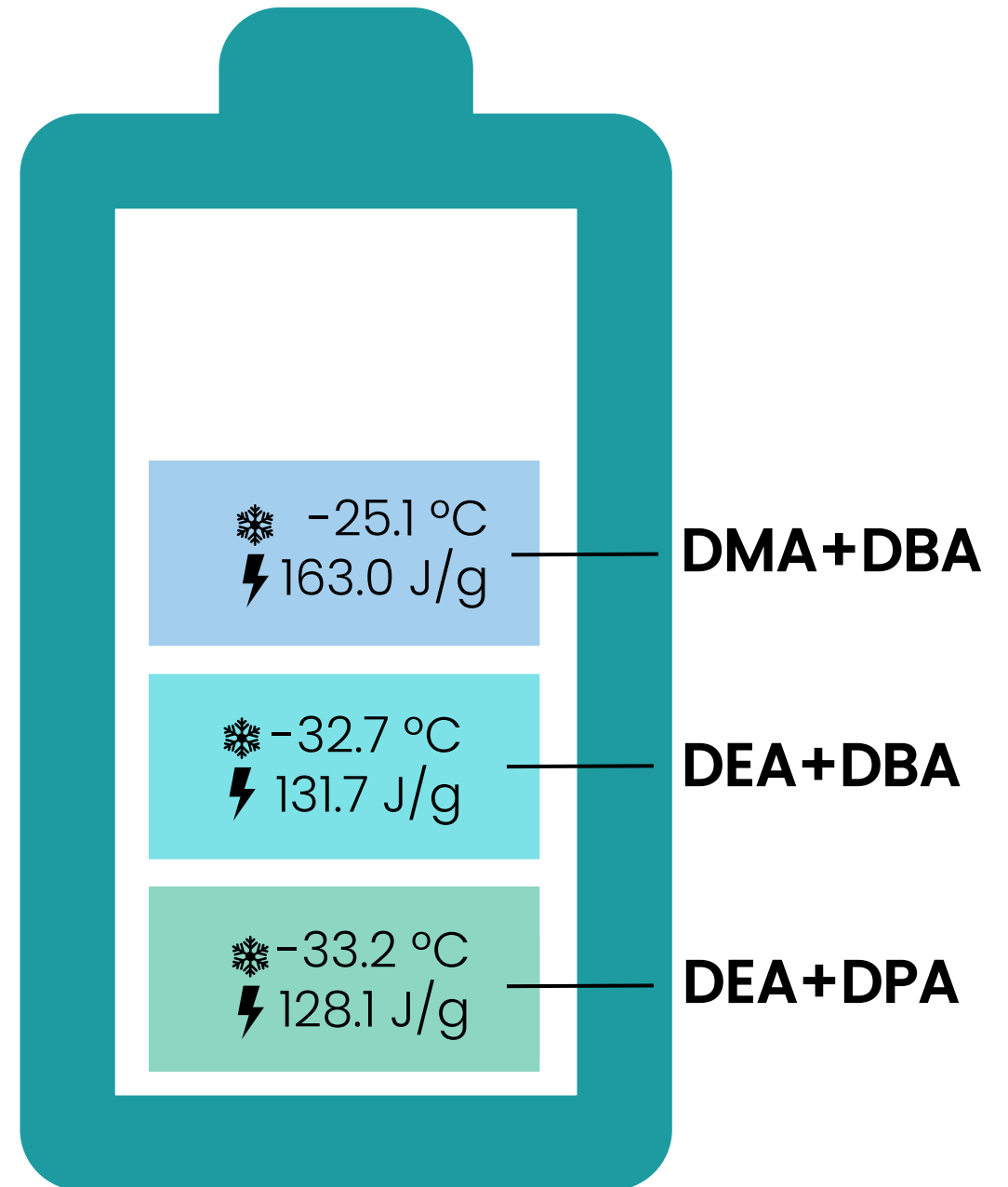

# Towards Cold Thermal Energy Storage

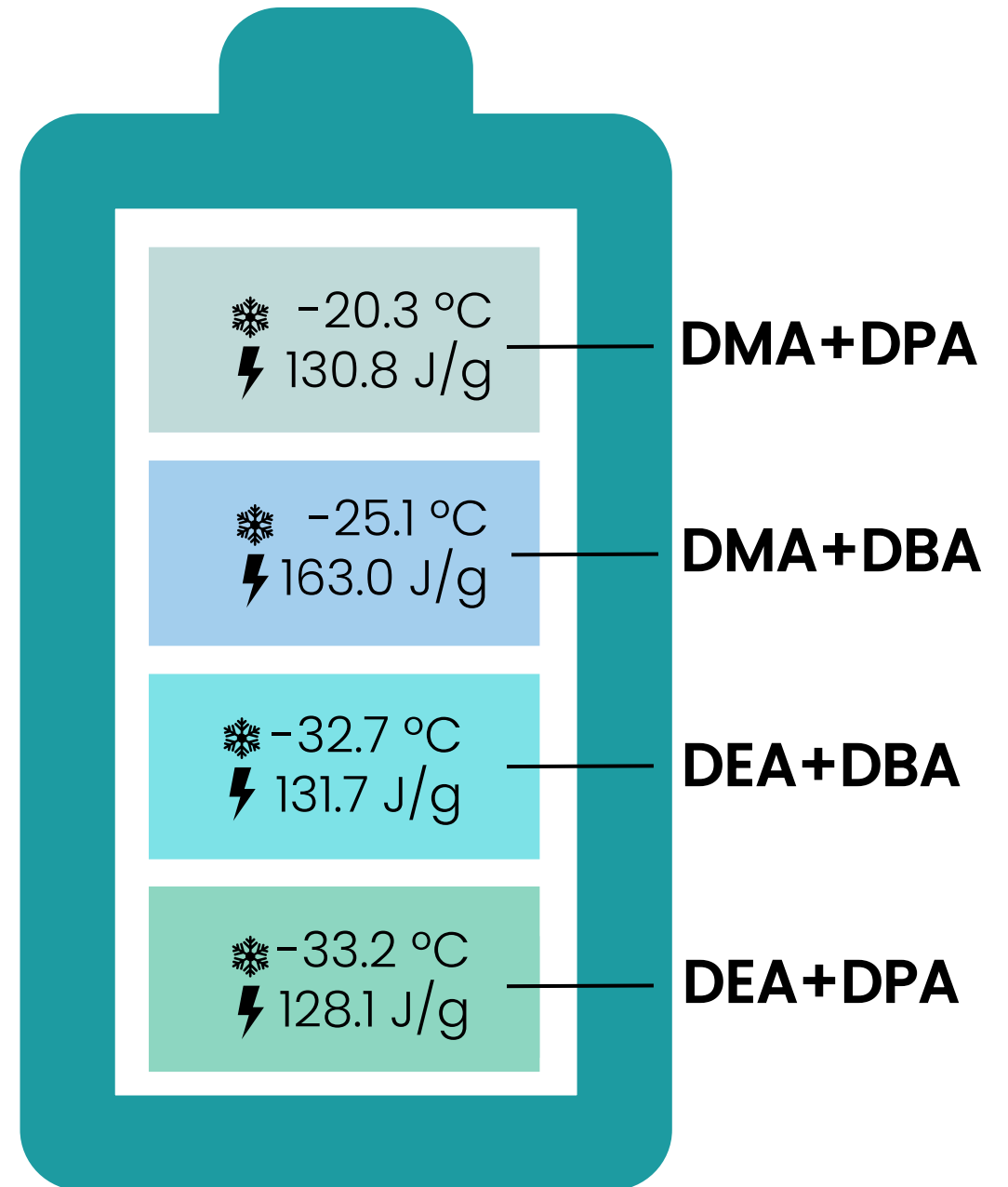

# Conclusions

**4  
Different  
Eutectic  
Systems**

# Conclusions

**4  
Different  
Eutectic  
Systems**

**Different  
Temperature  
Application**

# Conclusions

**4  
Different  
Eutectic  
Systems**

**Different  
Temperature  
Application**

**Similar Energy  
Storage  
Performance**

# Conclusions

**4  
Different  
Eutectic  
Systems**

**Different  
Temperature  
Application**

**Lack of  
Available  
Data on the  
Literature**

**Similar Energy  
Storage  
Performance**

# Conclusions

4  
Different  
Eutectic  
Systems

Different  
Temperature  
Application

Lack of  
Available  
Data on the  
Literature

Similar Energy  
Storage  
Performance

Contribution for Low  
Temperature Thermal  
Energy Storage  
Systems Optimization  
and Performance

3 GOOD HEALTH  
AND WELL-BEING



12 RESPONSIBLE  
CONSUMPTION  
AND PRODUCTION



13 CLIMATE  
ACTION



# AKNOWLEDGEMENTS

- Centro de Química Estrutural is a Research Unit funded by Fundação para a Ciência e a Tecnologia through projects UIDB/00100/2020 (<https://doi.org/10.54499/UIDB/00100/2020>), UIDP/00100/2020 (<https://doi.org/10.54499/UIDP/00100/2020>), UIDB/00313/2025 (<https://doi.org/10.54499/UIDB/00313/2025>) and UIDP/00313/2025 (<https://doi.org/10.54499/UIDP/00313/2025>). Institute of Molecular Sciences is an Associate Laboratory funded by Fundação para a Ciência e a Tecnologia through project LA/P/0056/2020 (<https://doi.org/10.54499/LA/P/0056/2020>).
- M.C.M. Sequeira acknowledges the PhD grant funded by FCT ref. UI/BD/152239/2021 (<https://doi.org/10.54499/UI/BD/152239/2021>).
- The ERA-Chair Spectroscopy@IKU - Manipulating and Characterizing Molecular Architectures: From Isolated Molecules to Molecular Crystals (Project number: 101184899) is funded by the European Research Agency under the HORIZON-WIDERA-2023-TALENTS-01-01 Program.