

UNIVERSIDADE ABERTA



UNIVERSIDADE  
**AbERTA**  
[www.uab.pt](http://www.uab.pt)

## Finite Bases for Semigroup Varieties

Manuel Jorge Raminhos Pereira

Doctor's Degree in Computational Algebra

Doctoral dissertation supervised by:

Dr João Araújo, Universidade Aberta  
Dr Edmond W. H. Lee, Nova Southeastern University

2019



# Resumo

O objetivo deste trabalho é fornecer um atlas das bases de identidades para as variedades geradas por semigrupos e grupos de ordem pequena. Com o propósito de auxiliar os matemáticos que trabalham neste campo a encontrar informações com facilidade, foi implementado um *website* que executa em segundo plano um conjunto de algoritmos desenvolvidos no âmbito deste trabalho e ainda ferramentas de demonstração automática e construtores de modelos finitos, para que o utilizador tenha um guia automático e inteligente. Por exemplo, o *site* fornece a primeira lista completa de variedades geradas por semigrupos de ordens iguais ou inferiores a 5, e consegue identificar rapidamente se a variedade gerada por um semigrupo inserido pelo utilizador, mesmo para ordens bastante superiores, coincide com uma das 218 variedades presentes na base de dados (atualmente inclui ainda outras 11 variedades geradas por semigrupos de ordens superiores). O *site* também fornece bases de identidades para classes arbitrariamente grandes de semigrupos, como bandas, ou a identificação dos semigrupos de ordem 6 conhecidos que geram variedades de base não finita. Além desta base de dados, o *site* propõe ainda uma lista das variedades geradas pelos semigrupos de ordem 6, num total de 414 conjecturas para novas variedades, entre as 463 identificadas neste trabalho e retirando as 49 variedades já conhecidas. O *site* disponibiliza ainda a informação para variedades geradas pelos grupos de ordens iguais ou inferiores a 255, obtida em resultado do levantamento e análise da literatura existente sobre as variedades geradas por estes grupos, para um total de 7012 grupos. O tratamento da informação recolhida para variedades geradas por grupos foi efetuado em GAP e através do desenvolvimento de algoritmos específicos para grupos comutativos e grupos metabelianos, nomeadamente para obtenção das identidades específicas de cada grupo, quando possível. O *site* oferece ainda um conjunto de funções sobre semigrupos, como encontrar o mínimo lexicográfico das cópias isomórficas de um dado semigrupo. Em relação à propriedade de base inerentemente não finita, o *site* pode decidir se um determinado semigrupo finito possui ou não essa propriedade; calcular a decomposição do semigrupo em semireticulados; ou converter a sintaxe da tabela de multiplicação de um semigrupo para utilização no GAP ou num demonstrador automático de teoremas/construtor de modelos finitos. O *site* fornece algumas outras funcionalidades, como uma ferramenta que gera a tabela de multiplicação de um semigrupo fornecida por uma apresentação em  $C$ , onde  $C$  é qualquer classe de álgebras definida por um conjunto de fórmulas em predicados de primeira ordem. A operação no sentido inverso também está acessível. O *site* disponibiliza um conjunto de informações e funcionalidades sobre variedades e as suas bases de identidades, como apresentar todas as inclusões entre as variedades da base de dados (variedades que são sub-variedades de outras variedades, que as contêm) em formato gráfico, identificar se a variedade gerada por um semigrupo coincide com uma existente na base de dados, ou identificar a variedade cuja base é equivalente ao conjunto de identidades inseridas pelo utilizador. O *site* consegue ainda listar todas as variedades da base dados cujas bases de identidades implicam ou são implicadas por um conjunto de identidades definidas pelo utilizador. Neste cálculo o *site* leva em conta o conhecimento prévio de todas as inclusões entre variedades acima referidas para acelerar o cálculo e minimizar o uso do demonstrador automático de

teoremas/construtor de modelos finitos. No desenvolvimento deste *site* foram utilizados: na implementação de algoritmos no servidor, Python, substituído pela versão compilada Cython em todos os cálculos intensivos; no desenvolvimento da interface cliente, JavaScript, JQuery, Ajax, Flask, HTML5, CSS3, Bootstrap e MathJax; em bases de dados relacionais, MySQL e SQLAlchemy; na preparação da informação presente nas bases de dados: GAP-System e em particular os “*packages*” *smallsemi* e *smallgroups*; na demonstração automática de teoremas e construção de modelos finitos, Prover9 e Mace4; na apresentação de diagramas, Graphviz. Foi desenvolvido um extenso conjunto de algoritmos reutilizáveis, para manipulação de variedades, semigrupos e grupos, organizados em bibliotecas, destacando-se: `varlib.pyx` – Implementa os algoritmos de cálculo intensivo do *site*, como o algoritmo que encontra o mínimo lexicográfico das cópias isomorfas de um dado semigrupo, ou o que verifica se um dado semigrupo satisfaz a base de identidades de uma das variedades na base de dados, e não satisfaz as identidades que definem as sub-variedades maximais. Por questões de velocidade, não existe nesta biblioteca recurso a demonstradores automáticos de teoremas ou a construtores de modelos finitos, sendo a sua funcionalidade substituída por algoritmos desenvolvidos otimizados para identidades, correndo nesta biblioteca a uma velocidade tipicamente 1000x superior ao mesmo programa em Python interpretado; `p9m4tools.py` – Implementa os algoritmos que recorrem ao demonstrador automático de teoremas e construtor de modelos finitos, embora em último recurso, por questões de desempenho, através da implementação de diversas técnicas de “cache”. Nesta biblioteca estão por exemplo os algoritmos desenvolvidos para obter um semigrupo e a sua tabela de multiplicação a partir de uma apresentação, e filtrar as variedades cuja bases de identidades implicam, são implicadas por, ou são equivalentes a um conjunto de identidades entradas pelo utilizador; `vartools.py` – Implementa rotinas de menor exigência computacional, como a interpretação da entrada de dados do utilizador (por exemplo tabelas de multiplicação em diversos formatos à escolha do utilizador) e a formatação dos dados a apresentar, quer em texto que de forma gráfica. Esta biblioteca inclui ainda diversos algoritmos sobre semigrupos, como a decomposição em semireticulados. Este trabalho também contribui para a extensão da base de dados de variedades conhecidas: existem 28634 semigrupos de ordem 6, considerados equivalentes quando isomorfos ou anti-isomorfos. As variedades de 2035 desses semigrupos não coincidem com nenhuma variedade conhecida gerada por semigrupos de ordem até 5. Neste projeto, com base no teorema de Birkhoff e aplicando novos algoritmos de computador e uma ferramenta de demonstração automática de teoremas/construtor de modelo finitos, foi possível dividir esses 2035 semigrupos em 463 conjuntos de semigrupos que satisfazem as mesmas identidades, correspondendo a 414 novas variedades propostas (dado que são já conhecidas 45 variedades de base finita e 4 variedades de base não finita, geradas por semigrupos da ordem 6). Além disso, as identidades candidatas para a bases de identidades para todas estas novas variedades também são propostas e apresentadas nesta tese, acompanhadas por todas as tabelas de Cayley e os IDs no “*package*” GAPs *smallsemi* correspondentes, para cada conjunto de semigrupos encontrados que geram a mesma variedade conjeturada. As provas dessas novas variedades representam problemas em aberto e um desafio para todos os matemáticos nesta área. A mesma metodologia pode ser utilizada para encontrar novas variedades candidatas geradas por semigrupos de ordem 7 ou maior (no âmbito deste trabalho

foram encontrados 73807 semigrupos não isomorfos de ordem 7 cujas variedades não coincidem com as variedades registadas na base de dados do *site*). Esta tese começa com um artigo <sup>1</sup> de pesquisa sobre variedades de semigrupos que contém a maior parte do conteúdo matemático desta tese. Este trabalho representa diversas contribuições para o campo do estudo das variedades de semigrupos: pela primeira vez foi reunida a informação dispersa sobre todas as variedades geradas por semigrupos de ordem igual ou inferior a 5, e relativa aos grupos de ordem igual ou inferior a 255, sendo apresentada num *site* de fácil utilização. O *site* oferece ainda um conjunto de funcionalidades sobre semigrupos e sobre variedades da base de dados, alicerçadas num conjunto de algoritmos desenvolvidos para maximização da performance e integrando uma interface, transparente para o utilizador, com um demonstrador automático de teorema e um construtor de modelos finitos, funcionando em paralelo para resultados mais rápidos. Adicionalmente, este trabalho contribuiu para o enriquecimento da base de dados de variedades geradas por semigrupos, ao propor conjeturas para todas as variedades não conhecidas geradas por semigrupos de ordem 6 e respetivas bases de identidades. As principais limitações deste trabalho estão relacionadas com o fato de alguns dos algoritmos desenvolvidos exigirem uma utilização intensiva de recursos computacionais (memória e processador). Estes algoritmos, ou não são adequados para colocação no *site* (como a pesquisa de novas variedades e respetivas bases), ou exigem limitações dos parâmetros de entrada (por exemplo o cálculo do mínimo lexicográfico, a geração de semigrupos a partir de apresentações, e a identificação de variedades, estão limitados a semigrupos de ordem inferior ou igual a, respetivamente, 10, 20 e 100). Noutras situações, embora raras, o *site* pode atingir o limite de memória permitido a cada utilizador. Este trabalho inspirou um alargado conjunto de ideias para trabalho futuro, e a primeira consiste na criação de um “*package*” GAP. Além de oferecer tudo o que *site* oferece e sem as limitações de memória e processador do *site*, o utilizador pode realizar múltiplas operações de forma automática. Na realidade o grosso do trabalho está pronto, já que este “*package*” se pode materializar apenas com o desenvolvimento de uma pequena camada de interface de comandos GAP, já que todos os algoritmos do *site* estão em bibliotecas autónomas e prontos para ser invocados por qualquer programa externo (aliás o acesso pelo GAP a rotinas das bibliotecas do *site* foi testado com sucesso no âmbito deste trabalho). Outras ideias para trabalho futuro passam por estender a procura de variedades às variedades geradas por semigrupos de ordem 7; melhorar os algoritmos atuais para propor também as identidades que definem as sub-variedades maximais; automatizar a demonstração das variedades conjeturadas; desenvolver uma interface no *site* que permita a extensão da base de dados com novas variedades pelos matemáticos; aumentar as funcionalidades sobre variedades de grupos; desenvolver novo algoritmo para acelerar o cálculo do mínimo lexicográfico.

Palavras-chave: Variedades de Semigrupos, Álgebra Computacional, Demonstração automática de teoremas, Enumeração combinatoria, Biblioteca de Dados, Grupos, Semigrupos, Interação, Visualização, Gráficos, Prover9/Mace4, Matemática, GAP

---

<sup>1</sup>Artigo submetido a uma revista internacional com *referee*.



# Abstract

The aim of this work was to provide an atlas of identity bases for varieties generated by small semigroups and groups. To help the working mathematician easily find information, a website was implemented, running in the background automated reasoning tools and finite model builders, so that the user has an automatic *intelligent* guide on the literature. For instance, the site provide the first complete the list of varieties generated by a semigroup of order up to 5. The website also provides identity bases for several types of semigroups or groups, such as bands, commutative groups, and metabelian groups. Regarding the inherent non-finite basis property, the website can decide whether or not a given finite semigroup possesses this property. The site provides some other functionalities such as a tool that outputs the multiplication table of a semigroup given by a  $C$ -presentation, where  $C$  is any class of algebras defined by a set of first order formulas. The inverse conversion is also available. This work also gives a contribution to the extension of the database of known varieties: there are 28634 nonisomorphic semigroups of order 6. The varieties of 2035 of these semigroups do not coincide to any known variety generated by semigroups of order up to 5. In this project, building on the Birkhoff theorem and applying new computer algorithms and automatic theorem proving, it was possible to divide these 2035 semigroups into 463 sets of semigroups that satisfy the same identities, corresponding to 414 new proposed varieties (since there are 45 known finitely-based and 4 known non-finitely based varieties generated by semigroups of order 6). Additionally, candidate identities for the identity basis for all these new varieties are also proposed and presented in this thesis, accompanied by all Cayley tables and the corresponding GAP smallsemi *package* IDs in each set of semigroups found. The proofs of these new varieties represent open problems and a challenge to all mathematicians in this field. The same methodology can be extended to find new candidate varieties generated by semigroups of order 7 or larger (within this work were found 73807 nonisomorphic semigroups of order 7 whose varieties do not coincide with known varieties registered in the site database).

Keywords: Semigroup Varieties, Computer Algebra, Automatic Theorem Proving, Enumerative combinatorics, Computer search, Data Library, Groups, Semigroups, Interaction, Visualization, Graphics, Mathematics, Prover9/Mace4, GAP



# Dedication

I am very grateful to my family, specially to my wife Nídia Antunes,  
for her tireless support since the beginning of this challenge,  
love you.



# Aknowledgments

I am very grateful to João Araújo, Edmond W. H. Lee, Peter J. Cameron and João Pedro Araújo for all the ideas and continuous support during my dissertation period.

A special thanks to João Araújo and Edmond W. H. Lee for the contagious energy and motivation they gave me throughout the project, and for the patience during times I was not able to maintain the work rhythm.



# Contents

<b>1</b>	<b>Introduction</b>	<b>1</b>
	A Survey on Varieties Generated by Small Groups and Semigroups and a Companion Website . . . . .	6
<b>2</b>	<b>Website</b>	<b>123</b>
2.1	Architecture . . . . .	123
2.2	Finding the least (lexicographically) semigroup . . . . .	127
2.3	Inputting multiplication tables . . . . .	129
2.4	Finding the identification system of a semigroup . . . . .	131
2.5	Generating a semigroup from a given presentation . . . . .	134
2.6	Generating a presentation from a given semigroup . . . . .	140
2.7	Testing equivalent identification systems . . . . .	141
2.8	Filtering varieties using conditions . . . . .	143
2.9	Obtaining lattices of varieties . . . . .	144
2.10	Extending the database: Finding generators and identity basis of un- known varieties . . . . .	145
2.11	Other tools: Latex reader . . . . .	148
<b>3</b>	<b>Open Problems</b>	<b>153</b>
<b>4</b>	<b>Conclusions</b>	<b>245</b>
4.1	Contributions . . . . .	245
4.2	Limitations . . . . .	245
4.3	Future work . . . . .	246
	<b>References</b>	<b>247</b>
	<b>Appendix A</b>	<b>255</b>



## List of Figures

1	Website architecture . . . . .	124
2	Function Dependency Graph: Cayley to Variety . . . . .	133
3	Cache implementation: Presentation to Cayley . . . . .	138
4	Function Dependency Graph: Presentation to Cayley . . . . .	139
5	Function Dependency Graph: Cayley to Presentation . . . . .	140
6	Function Dependency Graph: Variety basis equivalent to identities . . .	142
7	Function Dependency Graph: Variety basis which imply identities . . .	143
8	Function Dependency Graph: Extending the database . . . . .	147
9	Site displaying a variety . . . . .	150
10	Site displaying list of varieties . . . . .	151
11	Function Dependency Graph: Latex reader/Inclusions finder . . . . .	152



## List of Tables

1	Non-finitely based semigroups of order 6 . . . . .	3
2	Number of semigroups versus number of groups . . . . .	5
3	Main technologies used in this project . . . . .	123
5	Inputting a multiplication table . . . . .	129
6	Inputting presentations . . . . .	134
7	User options for filtering varieties . . . . .	143
8	Band varieties in the database . . . . .	144
9	Open Problems . . . . .	154



# Acronyms

AJAX (Asynchronous JavaScript and XML)

ATP (automated theorem prover) CSS (Cascading Style Sheets)

GAP (Groups, Algorithms, Programming)

HTML (Hyper Text Markup Language)

JSON (JavaScript Object Notation)

SQL (Structured Query Language)



# 1 Introduction

We assume familiarity with the general theory of universal algebra, varieties, semigroups, and groups. For general references, we suggest the monographs of Almeida [1], Burris and Sankappanavar [7], Howie [20], McKenzie *et al.* [53], and H. Neumann [57].

A *variety* of algebras is a class of algebras of a given type closed under the taking of subalgebras, homomorphic images and (possibly infinite) direct products. Birkhoff's celebrated theorem says that varieties are precisely the classes of algebras definable by identities. Familiar examples of varieties are semigroups (defined by the identity  $(xy)z = x(yz)$ ), inverse semigroups (defined by  $(xy)z = x(yz'')$ ,  $x = x(x'x)$  and  $((xx')(y'y) = (y'y)(xx'))$ ), groups (defined by the identities of inverse semigroups and  $xx' = y'y$ ), rings, loops, lattices, and many more. A familiar example of a non-variety are fields as the multiplicative inverse is not defined universally.

Given an algebra  $A$  we can think on the variety it generates, that is, the smallest class of algebras (of the same type as  $A$ ) that contains  $A$  and is closed under the taking of direct products, subalgebras and homomorphic images. As varieties are defined by identities, the next logical step is to ask for the identities that define the variety generated by a given algebra  $A$ .

The variety of semigroups (defined by one identity) satisfies many other identities, eg,  $(xy)(zw) = ((xy)z)w$ ,  $(xy)(zw) = x(y(zw))$ , etc., but all those identities are a consequence of the associativity law  $(xy)z = x(yz)$ . This is a general phenomenon: a variety satisfies infinitely many identities, but usually we want a *base* for the identities, that is, a set of identities from which every other identity holding in the variety can be inferred. When every identity holding in a variety can be inferred from a finite number of identities, the variety is said to have a finite *base* (of identities).

Some finite algebras generate varieties admitting a finite base, but some other finite algebras do not. For instance, all semigroups of order at most 5 generate finite based varieties, but there are 4 (and only 4, up to isomorphism) semigroups of order 6 generating a variety that cannot be defined by a finite number of identities. Another relevant example are groups. Every finite group generates a finite based variety of groups, in fact, a variety that can be defined by one single identity. Yet another example are bands (semigroups satisfying the identity  $x^2 = x$ , the idempotency law); every variety of bands can be defined by at most three identities (associativity, idempotency and an extra identity). These type of considerations gave rise to an entire area of mathematics, *equational logic*, where Alfred Tarski and his school excelled.

The discovery that every variety of groups generated by a finite group is finitely generated (Oates and Powell [58]), seemed to have produced a massive exodus from the area. In the sixties the area was very active with leading group theorists contributing to it, but suddenly by the early 70s (almost) everyone vanishes, with some important results announced but never really published. It seems people thought the topic was over, while in fact (as we will see later) many very difficult problems remained; it would be good if, now that we have the classification of finite simple groups, the topic would be resumed from experts in group theory.

The situation in semigroup theory is totally different. The fact that there are finite semigroups generating non-finitely based varieties led to the problem of finding which ones are which. The study of varieties of semigroups generated by finite semigroups

keeps being to this day one of the mainstream topics in semigroup theory.

A variety that contains only finitely many subvarieties is said to be *small*. It easily follows from the theorem of Oates and Powell [58] that every finite group generates a small variety of semigroups. But this result does not hold in general. A small counterexample is the monoid  $N_2^1$  obtained by adjoining an identity element to the nilpotent semigroup  $N_2 = \langle a \mid a^2 = 0 \rangle$  of order 2. Not only is the variety  $\mathbf{N}_2^1 = \text{var}\{N_2^1\}$  not small [13], it is the only non-small variety among all varieties generated by a semigroup of order 3 or less.

As for the variety generated by a semigroup of order greater than 3, properties more extreme than being non-small can be satisfied. For instance, there exist

- semigroups of order 4 that generate varieties that are *finitely universal* [32] in the sense that their lattices of subvarieties each embeds all finite lattices;
- semigroups of order 6 that generate varieties with continuum many subvarieties [12, 22].

All examples of varieties with continuum many subvarieties discovered so far are also finitely universal. It is unknown if there exists a variety of semigroups with continuum many subvarieties that is not finitely universal.

Whether or not smallness of a variety generated by a finite semigroup is decidable remains open, but one special case has been found. Recall that an identity of the form

$$x_1x_2 \cdots x_n \approx x_{\pi(1)}x_{\pi(2)} \cdots x_{\pi(n)},$$

where  $\pi$  is some nontrivial permutation on  $\{1, 2, \dots, n\}$ , is called a *permutation identity*, while a nontrivial identity of the form  $x_1x_2 \cdots x_n \approx \mathbf{w}$  that is not a permutation identity is said to be *diverse*.

**Proposition 1.1** (Malyshev [51]). *Any variety that satisfies some permutation identity and some diverse identity is small.*

As said above, every variety generated by a semigroup of order up to 5 is finitely based [40, 80, 82]. Among all varieties generated by a semigroup of order 6, precisely four are non-finitely based [43, 48]; these varieties are generated by the following semigroups:

- the monoid  $B_2^1$  obtained from the Brandt semigroup

$$B_2 = \langle a, b \mid a^2 = b^2 = 0, aba = a, bab = b \rangle = \{0, a, b, ab, ba\};$$

- the monoid  $A_2^1$  obtained from the 0-simple semigroup

$$A_2 = \langle a, b \mid a^2 = aba = a, bab = b, b^2 = 0 \rangle = \{0, a, b, ab, ba\};$$

- the semigroup  $A_2^g$  obtained by adjoining a new element  $g$  to  $A_2$  with  $g^2 = 0$  and  $gA_2 = A_2g = \{g\}$ ;
- the  $\mathcal{J}$ -trivial semigroup

$$L_3 = \langle a, b \mid a^2 = a, b^2 = b, aba = 0 \rangle = \{0, a, b, ab, ba, bab\}.$$

$B_2^1$	1 2 3 4 5 6	$A_2^1$	1 2 3 4 5 6
1	1 1 1 1 1 1	1	1 1 1 1 1 1
2	1 1 1 2 2 3	2	1 1 1 2 2 3
3	1 2 3 1 3 1	3	1 2 3 2 3 3
4	1 1 1 4 4 6	4	1 1 1 4 4 6
5	1 2 3 4 5 6	5	1 2 3 4 5 6
6	1 4 6 1 6 1	6	1 4 6 4 6 6
$A_2^g$	1 2 3 4 5 6	$L_3$	1 2 3 4 5 6
1	1 1 1 1 1 6	1	1 1 1 1 1 1
2	1 1 1 2 3 6	2	1 1 1 1 1 2
3	1 2 3 2 3 6	3	1 1 1 1 1 3
4	1 1 1 4 5 6	4	1 1 2 1 4 2
5	1 4 5 4 5 6	5	1 1 3 1 5 3
6	6 6 6 6 6 1	6	1 2 2 4 4 6

Table 1: Non-finitely based semigroups of order 6

The Cayley tables of these semigroups are given in Table 1; refer to Lee *et al.* [44] for more historical information on their discovery.

Besides the four non-finitely based semigroups of order six, many other non-finitely based finite semigroups have been discovered since the 1970s; see the survey by Volkov [89]. But explicit identity bases have not been found for varieties generated by most of these semigroups because the task is neither necessary (in establishing the non-finite basis property) nor trivial. Nevertheless, explicit identity bases are available for a few non-finitely based varieties.

**Proposition 1.2** (Jackson [24, Proposition 4.1]). *The identities*

$$x^4 \approx x^3, \quad x^3y \approx yx^3, \quad x^2yx \approx x^3y, \quad xyx^2 \approx x^3y, \quad xyxzx \approx x^3yz,$$

$$\left(\prod_{i=1}^m x_i\right) \left(\prod_{i=m}^1 x_i\right) y^2 \approx y^2 \left(\prod_{i=1}^m x_i\right) \left(\prod_{i=m}^1 x_i\right), \quad m = 1, 2, 3, \dots$$

constitute an identity basis for a non-finitely based variety generated by a certain semigroup of order 211.

**Proposition 1.3** (Lee and Volkov [47, Section 1]). *For each  $n \geq 2$ , the identities*

$$x^{n+2} \approx x^2, \quad (xy)^{n+1}x \approx yx, \quad xyxzx \approx xzxyx,$$

$$\left(\prod_{i=1}^m x_i^n\right)^3 \approx \left(\prod_{i=1}^m x_i^n\right)^2, \quad m = 2, 3, 4, \dots$$

constitute an identity basis for the non-finitely based variety  $\text{var}\{A_2, \mathbb{Z}_n\}$ . In particular,  $\text{var}\{A_2, \mathbb{Z}_2\} = \text{var}\{A_2^g\}$ .

**Proposition 1.4** (Lee [41, Corollary 3.5]). *For each  $n \geq 1$ , the identities*

$$x^{n+2} \approx x^2, \quad x^{n+1}yx^{n+1} \approx yx, \quad xhykxty \approx yhxkytx,$$

$$x \left( \prod_{i=1}^m (y_i h_i y_i) \right) x \approx x \left( \prod_{i=m}^1 (y_i h_i y_i) \right) x, \quad m = 2, 3, 4, \dots$$

constitute an identity basis for the non-finitely based variety  $\text{var}\{L_3, \mathbb{Z}_n\}$ .

The *finite basis problem*—first posed by Tarski [75] in the 1960s as a decision problem—questions which finite algebras are finitely based. This problem is undecidable for general algebras [52] but remains open for finite semigroups. In contrast, it is decidable if a finite semigroup  $S$  is *inherently non-finitely based* in the sense that every locally finite variety containing  $S$  is non-finitely based. This result follows from the work of Sapir [63, 64], a description of which requires the following concepts:

- the *period* of a semigroup  $S$  is the least number  $d$  such that  $S$  satisfies the identity  $x^{m+d} \approx x^m$  for some  $m \geq 1$ ;
- the *upper hypercenter* of a group  $G$ , denoted by  $\Gamma(G)$ , is the last term in the upper central series of  $G$ ;
- a word  $\mathbf{w}$  is an *isoterm* for a semigroup  $S$  if  $S$  violates every nontrivial identity of the form  $\mathbf{w} \approx \mathbf{w}'$ ;
- the *Zimin words*  $\mathbf{z}_1, \mathbf{z}_2, \mathbf{z}_3, \dots$  are words over the variables  $\{x_1, x_2, x_3, \dots\}$  defined inductively by  $\mathbf{z}_1 = x_1$  and  $\mathbf{z}_{k+1} = \mathbf{z}_k x_{k+1} \mathbf{z}_k$  for each  $k \geq 1$ .

**Theorem 1.5** (Sapir [66, Theorem 3.6.34]). (i) *A finite semigroup  $S$  is inherently non-finitely based if and only if there exists some idempotent  $e \in S$  such that the submonoid  $eSe$  of  $S$  is inherently non-finitely based.*

(ii) *A finite monoid  $M$  with period  $d$  is inherently non-finitely based if and only if there exist  $a \in M$  and an idempotent  $e \in MaM$  such that the elements  $ea^d e$  and  $ea^{d+1}e$  do not belong to the same coset of the maximal subgroup  $M_e$  of  $M$  containing  $e$  with respect to the upper hypercenter  $\Gamma(M_e)$ .*

(iii) *A finite semigroup  $S$  is inherently non-finitely based if and only if the Zimin words  $\mathbf{z}_1, \mathbf{z}_2, \dots, \mathbf{z}_m$ , where  $m = |S|^3$ , are isoterms for  $S$ .*

The non-finitely based semigroups  $A_2^g$  and  $L_3$  are not inherently non-finitely based because they satisfy the identities  $\mathbf{z}_2 \approx x_1(x_2x_1)^3$  and  $\mathbf{z}_2 \approx x_1x_2x_1^2$ , respectively. On the other hand, the semigroups  $A_2^1$  and  $B_2^1$  are inherently non-finitely based since all Zimin words are isoterms [64, Lemma 3.7]. It follows that a finite semigroup  $S$  is inherently non-finitely based if either  $A_2^1 \in \text{var}\{S\}$  or  $B_2^1 \in \text{var}\{S\}$ .

From the point of view of the working mathematician, a base of varieties for a given semigroup is very important. While working on some conjecture on semigroups, one might get a counter-example  $S$ ; unlike groups where all small models are well known, there are too many small semigroups. Therefore a tool that finds the identities satisfied by a given finite semigroup would be most useful. The problem is that the results are spread all over hundreds of different papers written in different languages; given a finite semigroup only a world class expert on the topic would know where to find information about it, if it exists.

$n$	Number of semi-groups of order $n$ , up to equivalence	Number of semi-groups of order $n$ , up to isomorphism	Number of groups of order $n$
2	4	5	1
3	18	24	1
4	126	188	2
5	1,160	1,915	1
6	15,973	28,634	2
7	836,021	1,627,672	1
8	1,843,120,128	3,684,030,417	5

Table 2: Number of semigroups versus number of groups

The goal of this thesis is to take advantage of the computational tools, symbolic computation (GAP) and automated theorem provers (ATP), to provide a living atlas of all the information available and much more. Precisely, due to the use of ATP we are able of providing new results that not long ago would give rise to some publication, but that now can be found by a computer. We also fill in some gaps left out in previous publications.

The thesis has the following parts: we start with the survey paper on varieties of semigroups that contains the bulk of the mathematical content of this thesis. Then we provide technical details of the architecture and main algorithms behind the website. We finish with some conclusions and future work.

# A Survey on Varieties Generated by Small Groups and Semigroups and a Companion Website

João Araújo\*    João Pedro Araújo    Peter J. Cameron†  
Edmond W. H. Lee    Jorge Raminhos

June 3, 2020

## Abstract

The aim of this paper is to provide an atlas of identity bases for varieties generated by small semigroups and groups. To help the working mathematician easily find information, we provide a companion website that runs in the background automated reasoning tools, finite model builders, and GAP, so that the user has an automatic *intelligent* guide on the literature.

This paper is a survey of what is known about identity bases for semigroups or groups of small orders, but we also mend some gaps left unresolved by previous authors. For instance, we provide the first complete and justified list of identity bases for the varieties generated by a semigroup of order up to 4; the companion website contains the list of varieties generated by a semigroup of order up to 5 and corresponding bases of identities; and we provide many bases for varieties generated by order 6 semigroups.

For higher orders, the website provides identity bases for several types of semigroups or groups, such as bands, commutative groups, and metabelian groups. Regarding the inherent non-finite basis property, the website can decide whether or not a given finite semigroup possesses this property. We provide many other functionalities such

---

\*Supported by the Fundação para a Ciência e Tecnologia (Portuguese Foundation for Science and Technology) through the project CEMAT-CIÊNCIAS UID/Multi/04621/2013, and through project Hilbert's 24th problem PTDC/MHC-FIL/2583/2014.

†Supported by the Fundação para a Ciência e Tecnologia (Portuguese Foundation for Science and Technology) through the project CEMAT-CIÊNCIAS UID/Multi/04621/2013

as a tool that outputs the multiplication table of a semigroup given by a  $C$ -presentation (where  $C$  is any class of algebras defined by a set of first order formulas), bibliographic information about the variety generated by a given finite semigroup  $S$ , its prime decomposition, varieties that cover it, a generator of smallest order, bases for the varieties of groups generated by the maximal subgroups of  $S$ , etc.

The paper ends with hundreds of open problems that range from very difficult research problems to potential projects for PhD dissertations or Master's thesis. The companion website can be found here:  
<http://sgv.pythonanywhere.com>

## Contents

<b>1</b>	<b>Introduction</b>	<b>9</b>
<b>2</b>	<b>Preliminaries</b>	<b>19</b>
2.1	Isomorphic semigroups and lexicographic minimum . . . . .	19
2.2	Varieties of semigroups . . . . .	20
2.3	Groups . . . . .	20
2.4	The lattice of varieties of bands . . . . .	20
2.5	Varieties with infinitely many subvarieties . . . . .	21
2.6	Epigroups . . . . .	22
2.7	Semilattice decomposition of semigroups . . . . .	23
<b>3</b>	<b>Varieties of groups</b>	<b>25</b>
3.1	The basics . . . . .	25
3.2	Abelian groups . . . . .	27
3.3	Metabelian groups . . . . .	27
3.4	Other groups . . . . .	29
3.5	Non-metabelian groups of order 24 . . . . .	30
3.6	Small groups . . . . .	32
3.7	Toward an explicit bound . . . . .	33
<b>4</b>	<b>The database of varieties generated by small semigroups</b>	<b>34</b>
4.1	Varieties generated by a semigroup of order up to 5 . . . . .	34
4.2	Non-finitely based varieties generated by a semigroup of order 6	34
4.3	Inherently non-finitely based finite semigroups . . . . .	36
<b>5</b>	<b>The companion webpage</b>	<b>49</b>
5.1	Multiplication table . . . . .	49
5.2	Finding the least semigroup of its isomorphism class . . . . .	50

5.3	Generating a semigroup from a given presentation . . . . .	50
5.4	Finding an identity basis for a finitely generated variety . . . . .	52
5.5	Testing for equivalent identity bases . . . . .	54
5.6	Filtering varieties using conditions . . . . .	55
5.7	Obtaining lattices of varieties . . . . .	56
5.8	Extending the database: finding identity bases for new varieties	57
<b>6</b>	<b>Varieties generated by small semigroups</b>	<b>58</b>
6.1	Varieties with primitive generator of order 2 . . . . .	62
6.2	Varieties with primitive generator of order 3 . . . . .	64
6.3	Varieties with primitive generator of order 4 . . . . .	67
6.4	Some varieties with primitive generator of order greater than 4	80
<b>7</b>	<b>Problems</b>	<b>84</b>
<b>A</b>	<b>Basic results on identities of some semigroups</b>	<b>87</b>
<b>B</b>	<b>Some finite lattices of varieties</b>	<b>90</b>
B.1	Subvarieties of $\mathbf{V}_{24} = \text{var}\{J, \overleftarrow{J}\}$ . . . . .	90
B.2	Subvarieties of $\mathbf{V}_{79} = \text{var}\{LZ_2^1, RZ_2^1\}$ . . . . .	90
B.3	Subvarieties of $\mathbf{V}_{35} = \text{var}\{J, LZ_2^1\}$ and $\mathbf{V}_{61} = \text{var}\{\overleftarrow{J}, RZ_2^1\}$ . .	91
B.4	Subvarieties of $\mathbf{V}_{42} = \text{var}\{\overleftarrow{J}, LZ_2^1\}$ and $\mathbf{V}_{60} = \text{var}\{J, RZ_2^1\}$ . .	92
B.5	Subvarieties of $\mathbf{V}_{56} = \text{var}\{O_2\}$ and $\mathbf{V}_{66} = \text{var}\{\overleftarrow{O}_2\}$ . . . . .	92
B.6	Subvarieties of $\mathbf{V}_{77} = \text{var}\{N_3, P_2\}$ and $\mathbf{V}_{81} = \text{var}\{N_3, \overleftarrow{P}_2\}$ . . .	94
B.7	Subvarieties of $\mathbf{V}_{26} = \text{var}\{Sl_2, N_3\}$ . . . . .	94
B.8	Subvarieties of $\text{var}\{N_3, \mathbb{Z}_n\}$ . . . . .	95
B.9	Subvarieties of $\text{var}\{J, \mathbb{Z}_p\}$ and $\text{var}\{Sl_2, \mathbb{Z}_{p^2}\}$ . . . . .	97
B.10	Subvarieties of $\mathbf{V}_{23} = \text{var}\{N_4\}$ . . . . .	100
<b>C</b>	<b>Some varieties with infinitely many subvarieties</b>	<b>100</b>
C.1	The variety $\text{var}\{\mathbb{Z}_p, N_n^1\}$ . . . . .	100
C.2	The varieties $\text{var}\{J, N_n^1\}$ and $\text{var}\{\overleftarrow{J}, N_n^1\}$ . . . . .	104
C.3	The varieties $\text{var}\{LZ_2, N_n^1\}$ and $\text{var}\{RZ_2, N_n^1\}$ . . . . .	107
C.4	The varieties $\text{var}\{LZ_2^1, N_n^1\}$ and $\text{var}\{RZ_2^1, N_n^1\}$ . . . . .	109
C.5	The varieties $\mathbf{V}_{38} = \text{var}\{B_0\}$ and $\mathbf{V}_{39} = \text{var}\{A_0\}$ . . . . .	112
C.6	The varieties $\mathbf{V}_{40} = \text{var}\{J^1\}$ and $\mathbf{V}_{46} = \text{var}\{\overleftarrow{J}^1\}$ . . . . .	112
	<b>References</b>	<b>114</b>

# 1 Introduction

We assume familiarity with the general theory of varieties, semigroups, and groups. As references we suggest the monographs of Almeida [1], Burris and Sankappanavar [7], Howie [20], McKenzie *et al.* [53], and H. Neumann [57].

Studying the lattice of varieties of semigroups is an old area of research, but given its complexity, this topic remains very active up to the present and certainly will continue into the foreseeable future. There are several very good surveys, such as Evans [13], Shevrin *et al.* [70], and Vernikov [87], that allow the reader to become familiar with the main results and problems. Our goal is different. We aim at a living survey powered by a companion computational tool that helps the working mathematician find new results or locate known ones in the literature.

As an illustration, suppose that we are researchers in some area of mathematics who, for some reason, need to investigate semigroups satisfying the implication

$$xy \approx yx \implies x \approx y,$$

objects we might call *anti-commutative semigroups*. To understand their properties, we could use **GAP** to find some small models, as for example, the semigroup  $U_1$  in Table 1. At a certain point, we observe that all elements of  $U_1$  are idempotents—such a semigroup satisfies the idempotency identity  $x^2 \approx x$  and is commonly called a *band*—and searching for varieties of bands we find a reference [14] that contains the lattice  $\mathcal{L}(\mathbf{B})$  of varieties of bands, as shown in Figure 1.

$U_1$	1	2	3	4	$U_2$	1	2	3	4	5
1	1	1	3	3	1	1	1	1	1	5
2	2	2	4	4	2	1	2	3	4	5
3	1	1	3	3	3	1	3	4	2	5
4	2	2	4	4	4	1	4	2	3	5
					5	1	5	5	5	5

Table 1: The semigroups  $U_1$  and  $U_2$

Again we could use **GAP** to see that our semigroup  $U_1$  satisfies the identity  $xyx \approx x$  but violates the identities  $xy \approx x$  and  $xy \approx y$ . Therefore the variety  $\text{var}\{U_1\}$  generated by  $U_1$  is contained in the variety of bands defined by the identity  $xyx \approx x$ —the variety **RB** of *rectangular bands*—but is excluded from its two maximal subvarieties **LZ** and **RZ**, whence  $\text{var}\{U_1\} = \mathbf{RB}$ . Now an easy exercise shows that a semigroup is anti-commutative if and only if it satisfies the identity  $xyx \approx x$ , and from here we get access to an enormous

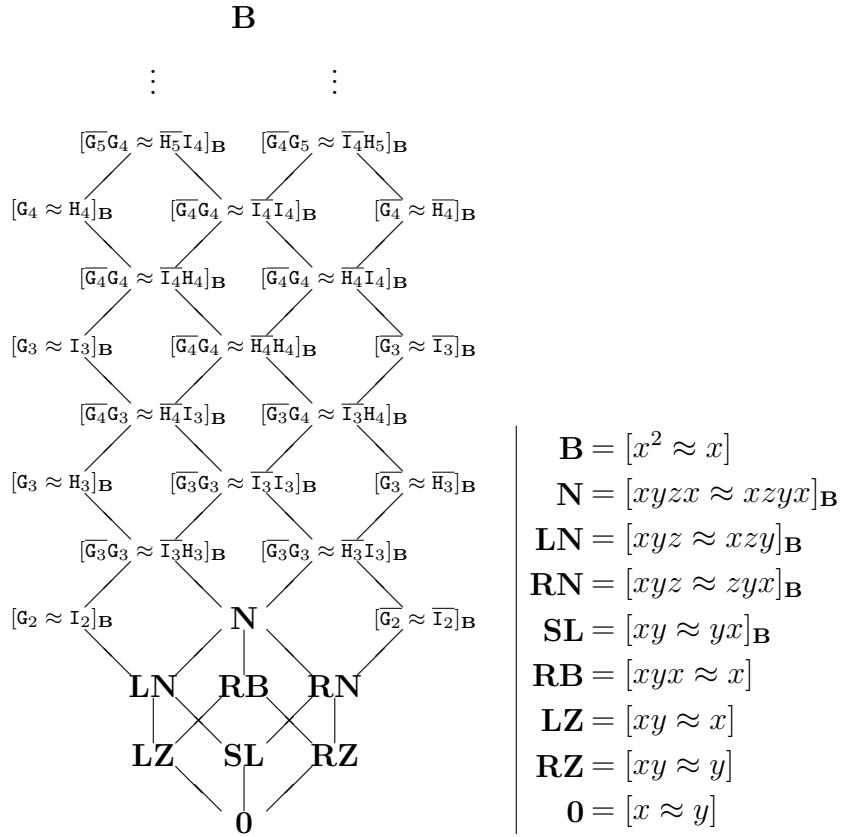

Figure 1: The lattice  $\mathcal{L}(\mathbf{B})$  of varieties of bands, where  $[\mathbf{u} \approx \mathbf{v}]_{\mathbf{B}} = \mathbf{B} \cap [\mathbf{u} \approx \mathbf{v}]$  and details on the words  $G_n, H_n, I_n, \overline{G}_n, \overline{H}_n, \overline{I}_n$  are given in Subsection 2.4.

amount of literature on our original object. The key steps in the above process were the observation that  $U_1$  is a band and the complete knowledge of the lattice of varieties of bands.

Now suppose that we are working with a different theory and our test semigroup is  $U_2$  in Table 1. Since  $U_2$  is not a band, there is no general lattice, similar to Figure 1, that allows us to repeat what we did with  $U_1$ . It turns out that the variety  $\text{var}\{U_2\}$  is defined by the identities  $\{x^4 \approx x, xyx \approx yx^2\}$ , but only a substantial search would allow us to locate a reference [78, Proposition 3.16].

In general, given a semigroup  $S$  of order up to 6, there is still a good chance that information on the variety  $\text{var}\{S\}$  and its subvarieties can be found in the literature, since such varieties have received much attention over the years [12, 30–39, 42, 45–47, 54, 78, 91, 94], especially in the investigation of the finite basis problem for small semigroups [10, 11, 40, 43, 48, 59, 63, 64, 77, 80,

82–84,95]. The first goal of this survey is to provide such information, but we go far beyond that. The overall aim is to provide a survey on identity bases defining varieties generated by finite semigroups and set up a companion website, running **GAP** and automated reasoning tools in the background, that will be periodically updated to better assist the working mathematician. Resources provided by the present survey and the website so far are described as follows.

- (a) Identity bases, and corresponding proofs or references, for all varieties generated by a semigroup of order up to 4. This survey is the first source providing this information.
- (b) Identity bases for the varieties covered by a given variety  $V$  (provided this is known). This information enables us to find the variety generated by a semigroup by showing that it satisfies the identities of  $V$ , but fails some identity in every variety covered by  $V$  (see Subsection 5.4). The same procedure is used when dealing with group varieties.
- (c) Identity bases for many varieties generated by semigroups of higher orders, including all semigroups of order 5, the proofs of which will be disseminated elsewhere.
- (d) Identity bases for varieties generated by various groups, including all groups of order less than 24 and all groups  $G$  that have abelian normal subgroups  $N$  such that  $\gcd(|N|, |G/N|) = 1$ .
- (e) For some classes of semigroups, including bands and some classes of groups, the website finds identity bases for varieties generated by arbitrarily large finite models; see Figure 4 on page 14.
- (f) For many finite semigroups  $S$ , the companion website gives bibliographic information about the variety  $\text{var}\{S\}$ , its prime decomposition, varieties that cover it, and a generator for  $\text{var}\{S\}$  of minimal order; see Figure 5 on page 42.
- (g) The *vector* of a semigroup  $S$  of order  $n$ , denoted by  $\vec{v}(S)$ , is the vector of dimension  $n^2$  that is formed by concatenating the  $n$  rows of the Cayley table of  $S$ . For example, the vector  $\vec{v}(J)$  of the semigroup  $J$  in Table 2 is  $[1, 1, 1, 1, 1, 1, 1, 2, 3]$  (on page 12); it is unambiguous, and in fact clearer, to only use commas to separate different rows, that is,

$$\vec{v}(J) = [111, 111, 123].$$

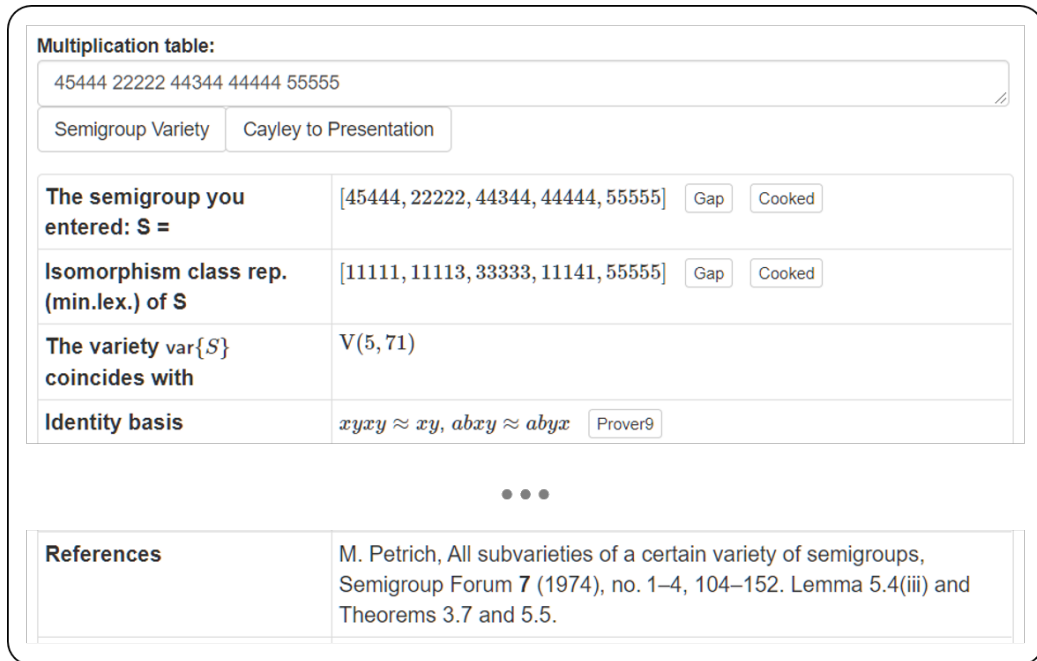

Figure 2: Companion website: example of a reference given for an order 5 semigroup

The isomorphic copies of a given semigroup can then be lexicographically ordered as vectors; for example, the semigroup  $J'$  in Table 2 is isomorphic to  $J$ , but since

$$\vec{v}(J) = [111, 111, 123] <_{\text{lex}} [333, 123, 333] = \vec{v}(J'),$$

we place  $J$  before  $J'$ . The companion website finds the smallest element in each isomorphism class and this is the standard form of the output; of course, this is an expensive feature that can only be applied to semigroups of relatively small order (up to 10). See Figure 6 on page 43.

$J$	1	2	3	$J'$	1	2	3
1	1	1	1	1	3	3	3
2	1	1	1	2	1	2	3
3	1	2	3	3	3	3	3

Table 2: The semigroups  $J$  and  $J'$

(h) For any finitely generated variety  $\mathbf{V}$ , there exist only finitely many

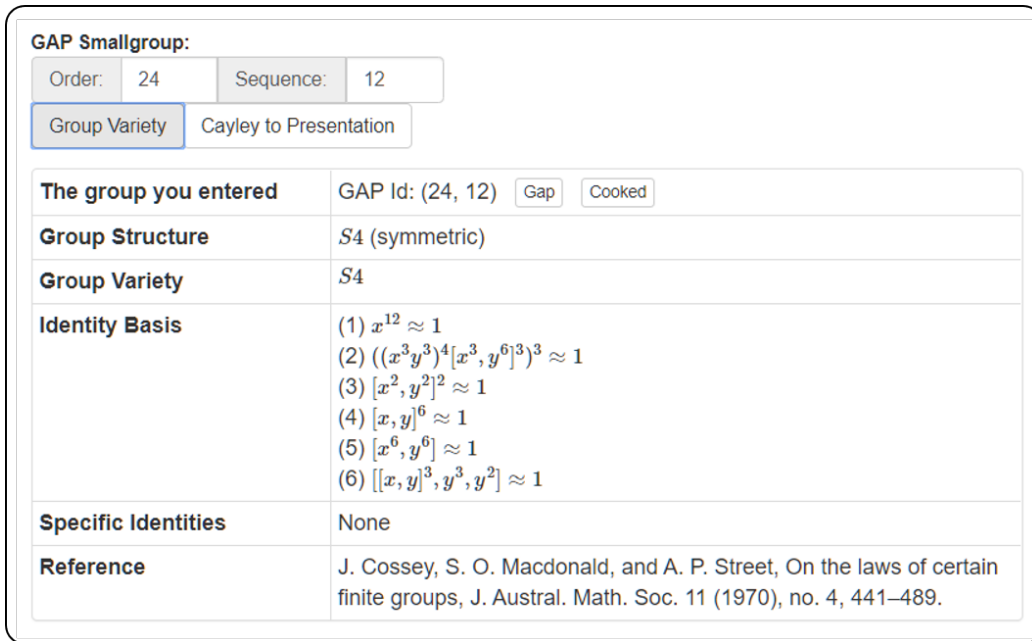

Figure 3: Companion website: the variety generated by the symmetric group  $S_4$

non-isomorphic generators of minimal order, say  $S_1, S_2, \dots, S_k$  with

$$\vec{v}(S_1) <_{\text{lex}} \vec{v}(S_2) <_{\text{lex}} \dots <_{\text{lex}} \vec{v}(S_k).$$

Then  $S_1$  is called the *primitive generator* of  $\mathbf{V}$ . Each variety has a label  $V(n, k)$ , where  $n$  is the order of its primitive generator  $S$  and  $k$  is the number of primitive semigroups of order  $n$  for other varieties that lexicographically precede  $S$ . For example, the variety  $\text{var}\{J\}$  is defined by the identities  $\{x^2 a \approx xa, xy^2 \approx yx^2\}$  and is labeled  $V(3, 3)$ , meaning that its primitive generator has order 3—which happens to be  $J$ —and there are two semigroups of order 3 with vectors preceding  $\vec{v}(J)$  that are primitive generators for two other distinct varieties, namely  $V(3, 1)$  and  $V(3, 2)$ . See Figure 7 on page 43.

- (i) The website provides a presentation for the primitive generator of the given variety. Conversely, the user can introduce a semigroup as a semigroup presentation in any variety or quasi-variety. For instance, Kiselman [26] considered the semigroup with the presentation

$$\left\langle c, \ell, m \mid \begin{array}{l} c^2 = c, \ell^2 = \ell, m^2 = m, clc = lc, lcl = lc, \\ cmc = mc, mcm = mc, lml = ml, mlm = ml \end{array} \right\rangle$$

**Multiplication table:**  
 00000000, 01011567, 22222222, 01033567, 01044567, 01055567, 01715567, 77777777

Semigroup Variety    Cayley to Presentation

<b>The semigroup you entered: S =</b>	[00000000, 01011567, 22222222, 01033567, 01044567, 01055567, 01715567, 77777777] <input type="button" value="Gap"/> <input type="button" value="Cooked"/>																		
<b>Isomorphism class rep. (min.lex.) of S</b>	[00000000, 01011567, 22222222, 01033567, 01044567, 01055567, 01715567, 77777777] <input type="button" value="Gap"/> <input type="button" value="Cooked"/>																		
<b>The variety <math>\text{var}\{S\}</math> coincides with</b>	Band(20)																		
<b>Identity basis</b>	$x \approx x^2$ $xyzazyx \approx xyzxazyxazyxazyx$																		
<b>Formula of induced identity</b>	$\overline{G_4}G_4 \approx \overline{H_4}H_4$																		
<b>Primitive generator</b>	[00000000, 01011567, 22222222, 01033567, 01044567, 01055567, 01715567, 77777777]																		
<b>Semilattice decomposition</b>	<pre> graph TD     A([4,5 V(2,3)]) --&gt; B([2,6,7 V(2,4)])     A --&gt; C([8,1,3 V(2,3)])     B --&gt; C     </pre>																		
<b>Epigroup identities</b>	$(x * y) * z = x * (y * z)$ . $x * x' = x' * x$ . $x' = (x' * x) * x'$ . $(x * x) * x' = x$ .																		
<b>Epigroup unary operation</b>	<table style="margin-left: auto; margin-right: auto;"> <tr> <td style="border-right: 1px solid black; padding-right: 5px;">'</td> <td>0</td><td>1</td><td>2</td><td>3</td><td>4</td><td>5</td><td>6</td><td>7</td> </tr> <tr> <td style="border-right: 1px solid black; padding-right: 5px;"></td> <td>0</td><td>1</td><td>2</td><td>3</td><td>4</td><td>5</td><td>6</td><td>7</td> </tr> </table>	'	0	1	2	3	4	5	6	7		0	1	2	3	4	5	6	7
'	0	1	2	3	4	5	6	7											
	0	1	2	3	4	5	6	7											

Figure 4: Companion website: the variety generated by an order 8 band

while investigating some operators in convexity theory. In less than a second the website shows that this semigroup has 17 elements as a semigroup presentation (as shown in Kiselman [26]), 7 elements as a band presentation, and 3 elements as a left cancellative semigroup presentation, etc. See Figure 8 on page 44.

- (j) The website does not provide an identity basis for the variety generated by the Kiselman semigroup of order 17 computed above. However, it will say that the Kiselman semigroup of order 7 generates the variety of semilattices whose primitive generator is the chain of length two. If a given semigroup  $S$  of arbitrarily finite order generates a variety whose primitive generator has order 5 or less, then the website will automatically provide an identity basis for the variety  $\text{var}\{S\}$ . See Figure 9 on page 45.
- (k) In addition to presentations, the user can input semigroups by giving the Cayley table, with several formats and on different sets that one can define, or by introducing identification numbers in the GAP libraries of small groups or small semigroups. See Figure 10 on page 46.
- (l) The companion website also provides information on dual varieties or self-dual ones when applicable. Recall that a variety of semigroups is *self-dual* if it is closed under anti-isomorphism.
- (m) Let  $\mathbf{E}_n$  denote the variety of unary semigroups defined by the identities

$$xx^* \approx x^*x, \quad x(x^*)^2 \approx x^*, \quad x^{n+1}x^* \approx x^n.$$

Then the proper inclusions  $\mathbf{E}_1 \subset \mathbf{E}_2 \subset \mathbf{E}_3 \subset \dots$  hold, and for any finite semigroup  $S$ , there exist a unary operation  $*$  on  $S$  and some minimal  $n \geq 1$  such that  $(S, *)$  is a unary semigroup in  $\mathbf{E}_n$ ; the companion website finds this natural number  $n$ . For more information on the operation  $*$  and the varieties  $\mathbf{E}_n$ , see Subsection 2.6 and Shevrin [69].

- (n) A semilattice  $Y$  is a partially ordered set in which every pair  $i, j \in Y$  of elements has a greatest lower bound  $i \wedge j$ , called the *meet* of  $i$  and  $j$ . A semigroup  $S$  is a *semilattice of semigroups* if there exist a semilattice  $(Y, \leq)$  and a family  $\{S_i\}_{i \in Y}$  of semigroups indexed by  $Y$  such that  $S = \bigcup_{i \in Y} S_i$  and  $S_i S_j \subseteq S_{i \wedge j}$ . Every semigroup can be decomposed into a semilattice of semigroups  $\{S_i\}_{i \in Y}$  with each  $S_i$  being semilattice indecomposable [74]. Based on results from Tamura [75], the companion website finds the largest semilattice decomposition of a given semigroup  $S$  into semilattice indecomposable semigroups  $\{S_i\}_{i \in Y}$ ,

and provides the variety generated by each  $S_i$ . This tool can be used on a relatively large semigroup  $S$ , even when we cannot determine an identity basis for the variety  $\text{var}\{S\}$ . See Figure 11 on page 47.

- (o) The website also gives bases of identities for the varieties generated by the maximal subgroups of a given semigroup.
- (p) Let  $\Sigma$  be some given first order theory. The companion website can find all the varieties  $\mathbf{V}$  in the database such that  $\Sigma \vdash \mathbf{V}$  or  $\mathbf{V} \models \Sigma$ .

**Assumptions:**  
 Enter assumptions using Prover9 syntax, for instance:  $x*y=y*x$ .

**Goals:**  
 $x * x = x$ .

Varieties whose identity basis is implied by the user's assumptions:      Varieties whose identity basis implies the user's goals:

Results:  
   

Variety	Primitive Generator	Identity Basis	Common Generator	# max. subvar.																									
V(1,1)	<table border="1" style="display: inline-table;"><tr><td>1</td></tr></table>	1	$x \approx y$	none	None																								
1																													
V(2,2)	<table border="1" style="display: inline-table;"><tr><td>1</td><td>1</td></tr><tr><td>1</td><td>2</td></tr></table>	1	1	1	2	$x^2 \approx x$ $xy \approx yx$	$Sl_2 = \{0,1\}$	1																					
1	1																												
1	2																												
V(2,3)	<table border="1" style="display: inline-table;"><tr><td>1</td><td>1</td></tr><tr><td>2</td><td>2</td></tr></table>	1	1	2	2	$ax \approx a$	$LZ_2 = \langle a,b \mid a^2 = ab = a, b^2 = ba = b \rangle = \{a,b\}$	1																					
1	1																												
2	2																												
...																													
V(5,142)	<table border="1" style="display: inline-table;"><tr><td>1</td><td>1</td><td>1</td><td>4</td><td>5</td></tr><tr><td>1</td><td>2</td><td>2</td><td>4</td><td>5</td></tr><tr><td>1</td><td>3</td><td>3</td><td>4</td><td>5</td></tr><tr><td>1</td><td>1</td><td>5</td><td>4</td><td>5</td></tr><tr><td>1</td><td>5</td><td>5</td><td>4</td><td>5</td></tr></table>	1	1	1	4	5	1	2	2	4	5	1	3	3	4	5	1	1	5	4	5	1	5	5	4	5	$x^2 \approx x$ $xay \approx xyxay$	none	1
1	1	1	4	5																									
1	2	2	4	5																									
1	3	3	4	5																									
1	1	5	4	5																									
1	5	5	4	5																									

Figure 12: Companion website: finding all varieties in the database that satisfy some given conditions

- (q) The companion website can provide a conjecture for the identity basis of a variety generated by a finite semigroup, using an algorithm that gave the correct result on all semigroups of order up to 5. Given the computational cost of the algorithm, anyone interested in using it to

find a candidate for an identity basis of a variety should perhaps first contact one of the authors.

For an illustrative example, consider the semigroup  $S$  with vector

$$\vec{v}(S) = [111111, 111222, 123123, 111444, 111555, 123456].$$

Lee [36] has proved that every subvariety of  $\text{var}\{S\}$  is finitely based; in particular, an identity basis for  $\text{var}\{S\}$  is

$$\Sigma_1 = \left\{ \begin{array}{l} x^2 \approx x^3, \quad xyx \approx x^2yx, \quad xyx \approx xyx^2, \\ xyzx \approx yxzx, \quad xyxy \approx xy^2x, \quad xhyxy \approx xhy^2x, \\ xyhxy \approx xyhyx, \quad xhytxy \approx xhytyx \end{array} \right\}.$$

Our algorithm produced the following candidate for an identity basis:

$$\Sigma_2 = \{x^2 \approx x^3, xyx \approx x^2yx, xyx \approx xyx^2, xyxy \approx xy^2x\}.$$

It is routine to verify that the identity systems  $\Sigma_1$  and  $\Sigma_2$  define the same variety, so that  $\Sigma_2$  is indeed an identity basis for  $\text{var}\{S\}$ . The identity basis  $\Sigma_2$  looks simpler than  $\Sigma_1$ , but we should observe that the main goal in [36] was to find a finite identity basis that is functional rather than one that is minimal.

- (r) In particular, the companion website can give some information about user's conjectures. Suppose that we have a semigroup  $S$  and guess that a certain set  $\Sigma$  of identities is an identity basis for  $\text{var}\{S\}$ . Then the website will check if  $\text{var}\{S\}$  is in the database; if yes, it will try to prove if the stored identity basis is equivalent to the given one and return the result (it is very unlikely that no result is returned in such a case). If  $\text{var}\{S\}$  does not belong to the database, then the website will try to find identities holding in  $S$ , but not provable from  $\Sigma$ . If some are found, then the result is returned. Otherwise, the user's conjecture is returned as a plausible one.

**Set of identities:**

Identities (or choose example below) ▾

$(x * x) * x = y * y.$   
 $(y * x) * x = x * y.$

Go!

<b>Variety</b>	V(2, 1)
<b>Identity basis</b>	$x^2 \approx xy, xy \approx yx$ <span style="border: 1px solid gray; padding: 2px;">Prover9</span>
<b>Primitive generator</b>	[11, 11]

Figure 13: Companion website: a set of identities entered by the user is found to be equivalent to an identity basis for a variety in the database

- (s) We will keep the website updated with new discovered results in order to have a state of the art tool assisting the work of mathematicians.

Section 2 contains some background material on varieties of groups and of semigroups, the lattice of varieties of bands, varieties with infinitely many subvarieties, an infinite chain of varieties of epigroups, and semilattice decompositions of semigroups. Section 3 surveys some known results on varieties generated by small groups; it consists of mostly old material and the main results here highlight the gaps in the literature waiting to be filled. It is our conviction that the topic was more or less *abandoned*, not because everything was too easy but exactly the opposite. Given the classification of finite simple groups, perhaps it is time for group theorists to start looking into varieties of groups again. For semigroup theorists, it might be useful to know to which varieties of groups belong the maximal subgroups (the  $\mathcal{H}$ -classes of idempotents) of the semigroup. Section 4 deals with varieties generated by a semigroup of order up to 5 and considers inherently non-finitely based finite semigroups. Section 5 introduces features of the companion website and explains how to use it. Section 6 provides the database of varieties generated by a semigroup of order up to 4. Then we have a list of open problems in Section 7, followed by three appendix sections providing justifications of results in Section 6.

## 2 Preliminaries

### 2.1 Isomorphic semigroups and lexicographic minimum

Two algebras  $A$  and  $B$  of the same type are said to be *isomorphic*, indicated by  $A \cong B$ , if there exists an isomorphism between them. The relation  $\cong$  is an equivalence relation on any class of algebras of the same type. Occasionally, given a finite algebra  $A$ , it is practical to have a canonical representative of the equivalence class  $[A]_{\cong}$ . For a semigroup  $S$ , an obvious choice for the representative of the class  $[S]_{\cong}$  is the semigroup whose vector lexicographically precedes the vectors of all other semigroups in  $[S]_{\cong}$ . For instance, consider the semigroup

$$P = \langle a, b \mid ab = a, ba = 0, b^2 = b \rangle = \{0, a, b\}.$$

Then there are six semigroups on the set  $\{1, 2, 3\}$  that are isomorphic to  $P$ , as shown in Table 3. Since  $\vec{v}(S_1) \leq_{\text{lex}} \vec{v}(S_i)$  for all  $i \neq 1$ , the semigroup  $S_1$  is the representative of the class  $[P]_{\cong}$ .

$S_1$	1	2	3	$S_2$	1	2	3	$S_3$	1	2	3
1	1	1	1	1	1	1	1	1	1	2	2
2	1	1	2	2	1	2	1	2	2	2	2
3	1	1	3	3	1	3	1	3	3	2	2
$S_4$	1	2	3	$S_5$	1	2	3	$S_6$	1	2	3
1	1	3	3	1	2	2	1	1	3	1	3
2	2	3	3	2	2	2	2	2	3	2	3
3	3	3	3	3	2	2	3	3	3	3	3

Table 3: Semigroups isomorphic to  $P$

The *dual* of a semigroup  $S$ , denoted by  $\overleftarrow{S}$ , is the semigroup obtained from  $S$  by reversing its operation, that is, for any  $a, b \in \overleftarrow{S} = S$ , the product  $ab$  in  $\overleftarrow{S}$  is equal to the product  $ba$  in  $S$ . The Cayley table of  $\overleftarrow{S}$  is obtained simply by transposing the Cayley table of  $S$ . For instance, the semigroup  $\overleftarrow{S}_1$  is isomorphic to the semigroup  $J$  in Figure 2. The *dual* of a variety  $\mathbf{V}$  is the variety

$$\overleftarrow{\mathbf{V}} = \{\overleftarrow{S} \mid S \in \mathbf{V}\}.$$

A variety  $\mathbf{V}$  is *self-dual* if  $\mathbf{V} = \overleftarrow{\mathbf{V}}$ .

Two semigroups  $S$  and  $T$  are *equivalent* if either  $S \cong T$  or  $\overleftarrow{S} \cong T$ . In the GAP package `Smallsemi`, semigroups are stored up to equivalence but not up to isomorphism, a decision not without some disadvantages. In the present survey, unless otherwise stated, we work with semigroups up to isomorphism.

## 2.2 Varieties of semigroups

The variety generated by an algebra  $A$ , denoted by  $\text{var}\{A\}$ , is the smallest class of algebras of the same type containing  $A$  that is closed under the formation of homomorphic images, subalgebras, and arbitrary direct products. Since a variety  $\text{var}\{A\}$  coincides with the class of all algebras that satisfy the identities of  $A$ , two algebras generate the same variety if and only if they satisfy the same identities. It is clear that if  $A$  and  $B$  are isomorphic algebras, then  $\text{var}\{A\} = \text{var}\{B\}$ ; however, the converse does not hold in general, even if the algebras  $A$  and  $B$  have the same order. For example, the dihedral group  $D_4$  and the quaternion group  $Q$  are groups of order 8 that generate the same variety [93], but they are not isomorphic.

Up to isomorphism, the number of semigroups of order up to 5 is 2133 [98, A027851], while the number of varieties generated by such a semigroup is only 218.

An *identity basis* for a variety  $\mathbf{V}$  is a set of identities holding in  $\mathbf{V}$  from which all other identities of  $\mathbf{V}$  can be deduced. A variety is *finitely based* if it possesses a finite identity basis. Since a semigroup satisfies the same identities as the variety it generates, it is unambiguous to define an *identity basis* for a semigroup  $S$  to be an identity basis for  $\text{var}\{S\}$ , and say that  $S$  is *finitely based* whenever  $\text{var}\{S\}$  is finitely based. Every semigroup of order up to 5 is finitely based, but up to isomorphism, precisely four semigroups of order 6 are non-finitely based [44] (see Subsection 4.2).

## 2.3 Groups

For a general reference on varieties of groups, we recommend the monograph of H. Neumann [57]. Unlike what happens in semigroups, every variety generated by a finite group has a finite identity basis, and in group theory, every finite set of identities is equivalent to a single identity. Therefore every variety generated by a finite group can be defined by a single identity. We will see a similar phenomenon in the variety of bands below. More details on varieties of groups can be found in Section 3.

## 2.4 The lattice of varieties of bands

A description of the lattice  $\mathcal{L}(\mathbf{B})$  of varieties of bands can be found in Birjukov [3], Fennemore [14], Gerhard [15], Gerhard and Petrich [17], and Howie [20]; see Figure 1. At the very top of the lattice is the variety  $\mathbf{B} = [x^2 \approx x]$  of all bands. In the lower region is the sublattice  $\mathcal{L}(\mathbf{N})$  of  $\mathcal{L}(\mathbf{B})$

consisting of eight varieties:

$\mathbf{N} = [xyzx \approx xzyx]_{\mathbf{B}}$ ,	normal bands;
$\mathbf{LN} = [xyz \approx xzy]_{\mathbf{B}}$ ,	left normal bands;
$\mathbf{RN} = [xyz \approx yxz]_{\mathbf{B}}$ ,	right normal bands;
$\mathbf{SL} = [xy \approx yx]_{\mathbf{B}}$ ,	semilattices;
$\mathbf{RB} = [xyx \approx x]$ ,	rectangular bands;
$\mathbf{LZ} = [xy \approx x]$ ,	left zero bands;
$\mathbf{RZ} = [xy \approx y]$ ,	right zero bands;
$\mathbf{0} = [x \approx y]$ ,	trivial bands.

The remaining varieties in the lattice  $\mathcal{L}(\mathbf{B})$  are defined by identities that are formed by the words  $\{\mathbf{G}_n, \mathbf{H}_n, \mathbf{I}_n \mid n \geq 2\}$  inductively defined as follows:

$$\begin{aligned} \mathbf{G}_2 &= x_2x_1, & \mathbf{H}_2 &= x_2, & \mathbf{I}_2 &= x_2x_1x_2, \\ \text{and } \mathbf{G}_n &= x_n\overline{\mathbf{G}_{n-1}}, & \mathbf{H}_n &= \mathbf{G}_nx_n\overline{\mathbf{H}_{n-1}}, & \mathbf{I}_n &= \mathbf{G}_nx_n\overline{\mathbf{I}_{n-1}}, \end{aligned} \quad \text{for all } n \geq 3,$$

where  $\overline{X}$  is the word  $X$  written in reverse. For example,

$$[\mathbf{G}_3 \approx \mathbf{H}_3]_{\mathbf{B}} = [x_3x_1x_2 \approx x_3x_1x_2x_3x_2, x^2 \approx x].$$

By simple inspection of the identities in Figure 1, it is clear that the varieties in column 3 are self-dual, the varieties in columns 1 and 5 are dual to each other, and the varieties in columns 2 and 4 are dual to each other.

The variety generated by a band  $B$  is the variety  $\mathbf{V}$  of bands that satisfies both of the following properties:  $B$  belongs to  $\mathbf{V}$  and  $B$  is excluded from every maximal subvariety of  $\mathbf{V}$ . When a semigroup  $S$  is entered into the companion website, there is a first test to check if  $S$  is a band. In the affirmative case, the website crawls up the lattice in Figure 1; the first identity satisfied by  $S$  defines the variety  $\text{var}\{S\}$ .

## 2.5 Varieties with infinitely many subvarieties

A variety that contains only finitely many subvarieties is said to be *small*. It easily follows from the well-known theorem of Oates and Powell [58] that every finite group generates a small variety of semigroups. But this result does not hold in general. A small counterexample is the monoid  $N_2^1$  obtained by adjoining an identity element to the nilpotent semigroup  $N_2 = \langle a \mid a^2 = 0 \rangle$  of order 2; see Figure 14 on page 48. Not only is the variety  $\mathbf{N}_2^1 = \text{var}\{N_2^1\}$  not small [13], it is the only non-small variety among all varieties generated by a semigroup of order 3 or less; see Section 6.

As for the variety generated by a semigroup of order greater than 3, properties more extreme than being non-small can be satisfied. For instance, there exist

- semigroups of order 4 that generate varieties that are *finitely universal* [32] in the sense that their lattices of subvarieties each embeds all finite lattices;
- semigroups of order 6 that generate varieties with continuum many subvarieties [12, 22].

All examples of varieties with continuum many subvarieties discovered so far are also finitely universal. It is unknown if there exists a variety of semigroups with continuum many subvarieties that is not finitely universal. Refer to Shevrin *et al.* [70] for a survey of results regarding other properties satisfied by lattices of varieties.

Given a finite semigroup, it is of natural interest to determine if it generates a small variety. Whether or not smallness of a variety is decidable remains open, but one special case has been found. Recall that an identity of the form

$$x_1x_2 \cdots x_n \approx x_{\pi(1)}x_{\pi(2)} \cdots x_{\pi(n)},$$

where  $\pi$  is some nontrivial permutation on  $\{1, 2, \dots, n\}$ , is called a *permutation identity*, while a nontrivial identity of the form  $x_1x_2 \cdots x_n \approx \mathbf{w}$  that is not a permutation identity is said to be *diverse*.

**Proposition 2.1** (Malyshev [51]). *Any variety that satisfies some permutation identity and some diverse identity is small.*

## 2.6 Epigroups

An element  $a$  of a semigroup  $S$  is said to be an *epigroup element* if there exists an integer  $n \geq 1$  such that  $a^n$  belongs to a subgroup of  $S$ , that is, the  $\mathcal{H}$ -class  $H_{a^n}$  of  $a^n$  is a group; if  $n = 1$ , then  $a$  is said to be *completely regular*. If we denote by  $e$  the identity element of  $H_{a^n}$ , then  $ae$  is in  $H_{a^n}$  and we define the *pseudo-inverse*  $a'$  of  $a$  by  $a' = (ae)^{-1}$ , where  $(ae)^{-1}$  denotes the inverse of  $ae$  in the group  $H_{a^n}$  [69, Subsection 2.1]. An *epigroup* is a semigroup consisting entirely of epigroup elements, and a *completely regular semigroup* is a semigroup whose elements are all completely regular. An important result is that all finite semigroups are examples of epigroups. Following Petrich and Reilly [62] for completely regular semigroups and Shevrin [69] for epigroups, it is now customary to consider an epigroup or a completely

regular semigroup  $(S, \cdot)$  as a *unary* semigroup  $(S, \cdot, ')$ , where  $x \mapsto x'$  is the map that sends each element to its pseudo-inverse.

For any semigroup  $S$ , let  $\text{Epi}(S)$  denote the set of all epigroup elements of  $S$  and let  $\text{Epi}_n(S)$  denote the subset of  $\text{Epi}(S)$  consisting of elements of index bounded by  $n$ . Then the inclusions

$$\text{Epi}_1(S) \subseteq \text{Epi}_2(S) \subseteq \cdots \subseteq \bigcup_{n \geq 1} \text{Epi}_n(S) = \text{Epi}(S)$$

hold, where  $\text{Epi}_1(S)$  consists of completely regular elements of  $S$ , and  $\text{Epi}(S) = S$  if and only if  $S$  is an epigroup.

For any  $a \in \text{Epi}_n(S)$ , let  $e_a$  denote the identity element of the group  $H_{a^n}$ . Then  $ae_a = e_aa$  is in  $H_{a^n}$  and the definition of *pseudo-inverse* introduced above leads to a characterization of the epigroup elements of the semigroup:  $a \in \text{Epi}(S)$  if and only if there exist some  $n \geq 1$  and some (necessarily unique) element  $a' \in S$  such that

$$a'aa' = a', \quad aa' = a'a, \quad a^{n+1}a' = a^n; \quad (2.1)$$

see Shevrin [69, Section 2]. If  $a$  is an epigroup element, then so is  $a'$  with  $a'' = aa'a$ . The element  $a''$  is always completely regular and  $a''' = a'$ . A standard notation in finite semigroup theory is to write  $a^\omega = aa'$  for an epigroup element  $a$ ; see, for example, Almeida [1]. Then

$$a^\omega = a''a' = a'a'', \quad (a')^\omega = (a'')^\omega = a^\omega,$$

and more generally, for any  $m \geq 1$ ,

$$a^\omega = (aa')^m = (a')^m a^m = a^m (a')^m.$$

For each  $n \geq 1$ , the class  $\mathbf{E}_n$  consisting of all epigroups  $S$  such that  $S = \text{Epi}_n(S)$  is a variety; in particular,  $\mathbf{E}_1$  is the class of completely regular semigroups. The chain  $\mathbf{E}_1 \subset \mathbf{E}_2 \subset \mathbf{E}_3 \subset \cdots$  of varieties has the following property: for any variety  $\mathbf{V}$  of epigroups, there exists a smallest  $n \geq 1$  such that  $\mathbf{V} \subseteq \mathbf{E}_n$  [69]. Given a finite semigroup  $S$ , the companion website finds the smallest  $n$  such that  $S \in \mathbf{E}_n$ . This occasionally leads to some useful information about the semigroup, but of course it does not match knowing an identity basis for  $\text{var}\{S\}$ .

## 2.7 Semilattice decomposition of semigroups

There are many ways that a semigroup can be decomposed into smaller sub-semigroups, for example, direct products, subdirect products, and Zappa–Szép extensions. Some have the property that each component cannot be

further decomposed using the same tool, in which case the decomposition is said to be *atomic*. An obvious example of atomic decompositions for finite algebras is the direct product decomposition as, resorting on an argument similar to the one used to prove that every natural number is a product of prime numbers, we can easily show that every finite algebra can be decomposed into a direct product of directly indecomposable algebras. Finding atomic decompositions of infinite semigroups is more difficult; according to Bogdanović *et al.* [5], there are only five known atomic decompositions of general semigroups: semilattice decompositions [74], ordinal decomposition [50],  $U$ -decomposition [68], orthogonal decomposition [6], and the general subdirect decomposition whose atomicity was proved by Birkhoff.

Here we will concentrate on semilattice decompositions of semigroups. We saw above that a semilattice is a commutative band. It is easy to prove that every semilattice  $Y$  induces a partially ordered set in which every pair  $i, j \in Y$  of elements has a meet  $i \wedge j$ ; conversely, every such partially ordered set induces a semilattice. Therefore, the term *semilattice* is commonly used to refer to a commutative band or a partially ordered set admitting meet of every pair of elements. In this subsection it is more convenient to use it in the latter sense.

We recall that a semigroup  $S$  is a *semilattice of semigroups* if there exist a semilattice  $(Y, \leq)$  and a collection  $\{S_i\}_{i \in Y}$  of semigroups indexed by  $Y$  such that  $S = \bigcup_{i \in Y} S_i$  and  $S_i S_j \subseteq S_{i \wedge j}$ . Every semigroup can be decomposed as a semilattice  $\{S_i\}_{i \in Y}$  of semigroups  $S_i$  that are semilattice indecomposable [74].

In Tamura [75], two equivalent ways of finding the smallest semilattice congruence are provided. For any semigroup  $S$ , let  $S^1$  denote the smallest monoid containing  $S$ , that is,

$$S^1 = \begin{cases} S & \text{if } S \text{ is not a monoid,} \\ S \cup \{1\} & \text{otherwise.} \end{cases}$$

Then the smallest semilattice decomposition of  $S$  is the smallest partition containing the sets  $\{\{xy, yx, yxy\} \mid (x, y) \in S^1 \times S^1\}$ .

The companion website finds the largest semilattice decomposition of a given semigroup  $S$  into semilattice indecomposable semigroups  $\{S_i\}_{i \in Y}$ , and provides the variety generated by each  $S_i$ . This tool can be used on a semigroup  $S$  of relatively large order, even when we cannot determine an identity basis for the variety  $\text{var}\{S\}$ .

**Multiplication table:**  
[[0, 0, 0, 0, 0, 0, 0], [0, 0, 5, 1, 5, 0, 1], [0, 6, 0, 2, 6, 2, 0], [0, 1, 2, 3, 4, 5, 6], [0, 6, 5, 4, 3, 2, 1], [0, 1, 0, 5, 1, 5, 0], [0, 0, 2, 6, 2, 0, 6]]

Semigroup Variety    Cayley to Presentation

**The semigroup you entered: S =** [0000000, 0051501, 0602620, 0123456, 0654321, 0105150, 0026206]

**Isomorphism class rep. (min.lex.) of S** [0000000, 0001122, 0120201, 0003355, 0123456, 0350503, 0351624]

**Is inherently non-finitely based**

$d = 2.0$   
 $e = 6$   
 $a = 1$   
 $H_e = [6]$   
 $ea e = 0$   
 $ea^{d+1}e = 0$

As it can be seen,  $ea e \notin H_e$ .

**Semilattice decomposition**

Figure 15: Companion website: semilattice decomposition of an order 7 INFB semigroup

### 3 Varieties of groups

The theory of varieties of groups differs from that of semigroups in several ways, which will be briefly mentioned here. In particular, after a decade of activities around the 1960s, the monograph of H. Neumann [57] was published; this is still the best reference for the subject. Also, notation used in H. Neumann [57] became standard among group theorists: we will point out some of the differences. In particular, varieties of groups are typically denoted by Fraktur capital letters, such as  $\mathfrak{A}$  for the variety of abelian groups; following the usage established earlier, we will use bold-face letters such as  $\mathbf{A}$  instead.

#### 3.1 The basics

As briefly noted in Section 2.3, every finite group has an identity basis that consists of one single group identity. Every group identity is equivalent to one of form  $\mathbf{w} \approx 1$ , where  $\mathbf{w}$  is a word in the variables and their inverses.

We can regard  $\mathbf{w}$  as an element of the free group  $F(X)$  over a countable set  $X$  of variables. The identities satisfied by a variety  $\mathbf{V}$  form a *fully invariant subgroup* of  $F(X)$ , one mapped into itself by all endomorphisms of the group. Thus there is a bijection between varieties of groups and fully invariant subgroups of  $F(X)$ .

Each finite nontrivial group with finite exponent  $e \geq 2$  satisfies the identity  $x^e \approx 1$  and so also the identity  $x^{e-1} \approx x^{-1}$ . Therefore any identity of a finite group is equivalent to one of the form  $\mathbf{w} \approx 1$ , where  $\mathbf{w}$  is a semigroup word. In fact, a more specific result holds. Recall that a *commutator word* is an element of the derived subgroup of the free group. Alternatively, a commutator word can be described as one in which the sum of the exponents of every variable is 0.

**Theorem 3.1** (B. H. Neumann [56]). *Every identity of a finite group with exponent  $e$  is equivalent to  $\{x^e \approx 1, \mathbf{w} \approx 1\}$  for some commutator word  $\mathbf{w}$ .*

A *factor* of a group  $G$  is a quotient of a subgroup of  $G$ , that is,  $H/K$  where  $K \trianglelefteq H \leq G$ ; it is *proper* unless  $H = G$  and  $K = 1$ . A *chief factor* is one where  $K \trianglelefteq G$  and  $H/K$  is a minimal normal subgroup of  $G/K$ ; a *composition factor* is a factor  $H/K$ , when  $H$  and  $K$  are subnormal in  $G$  (that is, terms in a descending series in which each term is normal in its predecessor) and  $K$  is a maximal normal subgroup of  $H$ .

If  $A$  and  $B$  are subgroups of  $G$ , then  $[A, B]$  is the subgroup generated by the commutators in  $\{[a, b] \mid a \in A, b \in B\}$ . The *lower central series* is the descending series  $G = G_1 > G_2 > \dots$  with  $G_{i+1} = [G_i, G]$ ;  $G$  is *nilpotent of class  $c$*  if  $c$  is the smallest integer such that  $G_{c+1} = 1$ . The *derived series* is the descending series  $G = G^{(0)} > G^{(1)} > \dots$  with  $G^{(i+1)} = [G^{(i)}, G^{(i)}]$ ;  $G$  is *solvable of derived length  $\ell$*  if  $\ell$  is the smallest integer such that  $G^{(\ell)} = 1$ .

The *product*  $\mathbf{UV}$  of varieties  $\mathbf{U}$  and  $\mathbf{V}$  consists of all groups  $G$  that are *extensions* of a group  $H \in \mathbf{U}$  by a group  $K \in \mathbf{V}$ , that is,  $G$  has a normal subgroup isomorphic to  $H$  with quotient isomorphic to  $K$ . The product of two varieties is a variety, and the product operation is associative. But product varieties are not usually generated by finite groups.

**Theorem 3.2** (Šmel'ken [72]). *A product of three or more nontrivial varieties is not generated by a finite group. A product  $\mathbf{UV}$  is generated by some finite group if and only if  $\mathbf{U}$  and  $\mathbf{V}$  have coprime exponents,  $\mathbf{U}$  is nilpotent, and  $\mathbf{V}$  is abelian.*

The variety  $\mathbf{UV}$  has an identity basis of the form  $\mathbf{u}(\mathbf{v}_1, \mathbf{v}_2, \dots, \mathbf{v}_n) \approx 1$ , where  $\mathbf{u}(x_1, x_2, \dots, x_n) \approx 1$  is an identity of  $\mathbf{U}$  and each  $\mathbf{v}_i \approx 1$  is an identity of  $\mathbf{V}$ . (Note that, even if for some cases we can do better, usually all identities

of  $\mathbf{V}$  are needed, not just an identity basis.) We will give more details in an important special case in Subsection 3.3.

Many further results about varieties of groups are known, but the interest of the present survey lies in those that are finitely generated.

One important result on varieties of groups is the *Oates–Powell Theorem*, asserting that, for any finite group  $G$ , the variety  $\text{var}\{G\}$  is finitely based. The result is actually much stronger. Recall that a variety of algebras of any type is *finitely generated* if it is generated by one of its finite algebras. A variety is *Cross* if it is finitely based, finitely generated, and small.

**Theorem 3.3** (Oates and Powell [58]). *The variety generated by any finite group is Cross.*

A group is *critical* if it does not lie in the variety generated by all of its proper factors. A variety of groups  $V$  is generated by all critical group in  $V$ . Sometimes one critical group is enough to generate  $V$ , but sometimes it is not. For example,  $\mathbf{A}_6$  has critical groups  $C_2$  and  $C_3$  and both are needed to generate the variety; on the other hand,  $\mathbf{A}_2\mathbf{A}_2$  is generated by either one of its critical groups  $D_8$  and  $Q_8$  (for definitions see below).

A critical group is monolithic, that is, it has a unique minimal nontrivial normal subgroup. It is known that, if a variety of groups admits two different critical groups, then their monoliths are abelian. Hence non-isomorphic finite simple groups generate different varieties.

## 3.2 Abelian groups

The structure of the lattice of varieties generated by abelian groups is very simple. The class  $\mathbf{A}$  of all abelian groups is the variety defined by the identity  $[x, y] \approx 1$ ; for each integer  $m \geq 1$ , the class  $\mathbf{A}_m$  of abelian groups of exponent dividing  $m$  is the variety defined by the identities  $x^m \approx [x, y] \approx 1$ . Hence the lattice of varieties of abelian groups is isomorphic to the set of positive integers ordered by divisibility, with a top element added. We remark that GAP includes commands `IsAbelian` and `Exponent`, so these conditions are easily checked.

Inclusions in the other direction are more problematic. For sufficiently large  $m$ , there are uncountably many varieties of groups covering  $\mathbf{A}_m$  [21, 29].

## 3.3 Metabelian groups

A group is *metabelian* if it lies in the product variety  $\mathbf{AA}$ , that is, it has an abelian normal subgroup with abelian quotient. Among small groups, many are metabelian; for example, 1,005 of the 1,048 groups of order up to 100

are metabelian. The smallest non-metabelian groups are the groups  $S_4$  and  $SL(2, 3)$  of order 24.

A finite metabelian group lies in the variety  $\mathbf{A}_m\mathbf{A}_n$  for some  $m, n \geq 1$ . The smallest subgroup of a group  $G$  whose quotient is abelian of exponent dividing  $n$  is generated by the  $n$ th powers and commutators in  $G$ , so the variety  $\mathbf{A}_m\mathbf{A}_n$  is defined by the identities

$$x^{mn} \approx [x, y]^m \approx [x^n, y^n] \approx [x^n, [y, z]] \approx [[x, y], [z, w]] \approx 1.$$

However, finding an identity basis for individual finite metabelian groups is more difficult.

Higman [19] showed that for each prime  $p$  and  $n \geq 1$  with  $p \nmid n$ , the proper subvarieties of  $\mathbf{A}_p\mathbf{A}_n$  containing  $\mathbf{A}_{pn}$  are characterized by an identity of the form

$$[x^n, y^{d_1}, y^{d_2}, \dots, y^{d_k}] \approx 1,$$

where  $d_1 > d_2 > \dots > d_k \geq 1$  are divisors of  $n$  such that  $d_i$  does not divide  $d_j$  whenever  $i > j$ .

As an example which we will examine later, consider the subvariety  $\text{var}\{A_4\}$  of  $\mathbf{A}_2\mathbf{A}_3$ . The only possible Higman identity is  $[x^3, y] \approx 1$ , which does not hold in  $A_4$ . Therefore  $\text{var}\{A_4\} = \mathbf{A}_2\mathbf{A}_3$ .

H. Neumann [57, p.179] quotes a generalization of this, an unpublished result of C. H. Houghton according to which, assuming that  $\gcd(m, n) = 1$ , any such variety lies between  $\mathbf{A}_{rs}$  and  $\mathbf{A}_r\mathbf{A}_s$  for some  $r, s \geq 1$  such that  $r$  divides  $m$  and  $s$  divides  $n$ . Moreover, such a variety is defined by identities of the form

$$[x^s, y^{d_1}, \dots, y^{d_k}]^t \approx 1,$$

where  $t$  is a divisor of  $r$  and  $d_1 > d_2 > \dots > d_k \geq 1$  are divisors of  $n$  such that  $d_i$  does not divide  $d_j$  whenever  $i > j$ .

Houghton did not publish the proof of his result. The proof, and a generalization that determines when the equality  $\text{var}\{A\} \text{var}\{B\} = \text{var}\{A \text{ wr } B\}$  holds for abelian groups  $A$  and  $B$ , can be found in Mikaelian [55].

There are also results for the case when the condition  $\gcd(m, n) = 1$  is relaxed. An important example, which consists of dihedral groups, is discussed below.

For an example, consider `SmallGroup(12,1)` in GAP with presentation

$$\langle a, b \mid a^3 = 1, b^4 = 1, b^{-1}ab = a^2 \rangle.$$

Clearly, this group lies in  $\mathbf{A}_3\mathbf{A}_4$ . As  $\gcd(m, n) = 1$ , this group can be handled with Higman's Theorem. The possible Higman identities are  $[x^4, y] \approx 1$  and  $[x^4, y^2] \approx 1$ . It is readily shown that the second is satisfied but the first is not.

Adding  $[x^4, y^2] \approx 1$  to the identity basis we see that the identity  $[x^4, y^4] \approx 1$  is redundant and can be discarded. Further reductions are possible, but we do not strive for the simplest identity basis.

A result of Kovács [27] describes the variety generated by a finite dihedral group. We have restated his theorem in a format that is more useful for us.

**Theorem 3.4.** *Let  $D_{2n}$  be the dihedral group of order  $2n$ , where  $n = 2^d m$  and  $m$  is odd.*

- (i) *If  $d \leq 1$ , then  $\text{var}(D_{2n}) = \mathbf{A}_m \mathbf{A}_2$ .*
- (ii) *If  $m = 1$  and  $d > 2$ , then  $\text{var}(D_{2n}) = \mathbf{A}_{2^{d-1}} \mathbf{A}_2 \cap \mathbf{N}_d$ , where  $\mathbf{N}_d$  is the variety of nilpotent groups of class at most  $d$ .*
- (iii) *If  $m > 1$  and  $d > 2$ , then  $\text{var}(D_{2n}) = \text{var}(D_{2m}, D_{2^{d+1}})$ .*

Now it follows from our general remarks on metabelian groups that an identity basis for  $\mathbf{A}_n \mathbf{A}_2$  is given by  $x^{2n} \approx [x^2, y^2] \approx 1$ . (For a group lies in this variety if and only if the squares commute and have orders dividing  $n$ .) An identity basis for  $\mathbf{N}_d$  is given by the *left-normed commutator*  $[x_1, x_2, \dots, x_{d+1}] \approx 1$  (which means  $[[\dots [[x_1, x_2], x_3], \dots], x_{d+1}] \approx 1$ ). Given varieties  $\mathbf{V}$  and  $\mathbf{W}$ , an identity basis for  $\mathbf{V} \cap \mathbf{W}$  consists of the union of the identity bases for  $\mathbf{V}$  and  $\mathbf{W}$ . Finally, the identities of  $\text{var}(G, H)$  consist of all products of an identity for  $G$  and an identity for  $H$  (in disjoint sets of variables). So the identities for varieties of dihedral groups can be described explicitly.

### 3.4 Other groups

Apart from the above, results about particular finite groups are fairly scarce. Cossey and Macdonald [8] and Cossey *et al.* [9] found explicit identity bases for the varieties  $\text{var}\{G\}$ , where  $G \in \{S_4, A_5, \text{PSL}(2, 7)\}$ ; they also found identities that hold in  $\text{PSL}(2, p^m)$  with prime  $p$ , but without proof that these identities form an identity basis. In the case  $p = 2$ , an identity basis was found by Southcott [73].

Such cases are best dealt with by database lookup.

Description for the identities of the groups  $\text{SL}(2, q)$  in some cases—when  $q = 9$  or  $q = p^m$  for some odd prime  $p \not\equiv \pm 1 \pmod{16}$  and odd  $m \geq 1$ —are also available. In these cases, the identities are of the form  $[\mathbf{w}, x] \approx 1$  and  $\mathbf{w}^2 \approx 1$ , where  $\mathbf{w} \approx 1$  ranges over an identity basis for  $\text{PSL}(2, q)$  and  $x$  is a variable not occurring in  $\mathbf{w}$ .

In particular, this result holds for  $\text{SL}(2, 3)$  and  $\text{PSL}(2, 3) \cong A_4$ , where identities of the latter group have been described in Subsection 3.3.

### 3.5 Non-metabelian groups of order 24

As noted earlier,  $S_4$  and  $\text{SL}(2, 3)$  are the only non-metabelian groups of order 24. An identity basis for the variety  $\text{var}\{S_4\}$  can be found in Cossey *et al.* [9]:

$$x^{12} \approx ((x^3 y^3)^4 [x^3, y^6]^3)^3 \approx [x^2, y^2]^2 \approx [x, y]^6 \approx [x^6, y^6] \approx [[x, y]^3, y^3, y^2] \approx 1.$$

The goal of this subsection is to describe the subvarieties of the varieties  $\text{var}\{S_4\}$  and  $\text{var}\{\text{SL}(2, 3)\}$ , and to show that their proper subvarieties are all metabelian.

**Lemma 3.5.** *Let  $G$  be any non-abelian group in  $\text{var}\{S_3\}$ . Then  $G$  has a subgroup isomorphic to  $S_3$ .*

*Proof.* We know that  $G'$  is a nontrivial elementary abelian 3-group while  $G/G'$  is an abelian group that is a direct product of elementary abelian 2-groups and 3-groups. Since  $G$  is non-abelian, there must be elements  $a, b \in G$  that fail to commute. We consider various cases, assuming that there is no subgroup isomorphic to  $S_3$  and aiming for a contradiction. Note that any two elements of order 3 commute, since each of them is a square and  $[x^2, y^2] \approx 1$  is an identity of  $S_3$ .

- $a$  and  $b$  have order 2. Then  $\langle a, b \rangle$  is a dihedral group of order 6 or 12 and so contains a subgroup isomorphic to  $S_3$ . So we may assume that involutions commute.
- $a$  has order 2 and  $b$  has order 3. Then  $c = b^a$  is another element of order 3 and  $c$  commutes with  $b$ . Since  $(bc^{-1})^a = cb^{-1} = (bc^{-1})^{-1}$ , the subgroup  $\langle a, b \rangle$  is isomorphic to  $S_3$ . Hence we can assume that elements of prime orders commute.
- $a$  has order 2 or 3 and  $b$  has order 6. Then  $a$  commutes with  $b^2$  and  $b^3$ , and so with  $b$ .
- $a$  and  $b$  have order 6. Then  $a^2$  and  $a^3$  both commute with  $b$ , so that  $a$  and  $b$  commute.

The proof is thus complete. □

**Theorem 3.6.** *Let  $G$  be any critical group in  $\text{var}\{S_4\}$  that is not metabelian. Then  $\text{var}\{G\} = \text{var}\{S_4\}$ .*

*Proof.* Let  $N$  be the verbal subgroup of  $G$  corresponding to the identities of  $\text{var}\{S_3\}$ , that is, the subgroup generated by values in  $G$  of the identities

of  $S_3$ . Then  $N$  is an elementary abelian 2-group, and it is nontrivial because  $1 \neq G'' \leq N$ . Further,  $G/N$  belongs to  $\text{var}\{S_3\}$ .

If  $G/N$  is abelian, then  $G' \leq N$ , so that the contradiction  $G'' = 1$  is deduced. Therefore  $G/N$  is non-abelian. Further,  $G/N$  has order divisible by 3, since otherwise  $G$  is a 2-group; but 2-groups in  $\text{var}\{S_4\}$  belong to  $\text{var}\{D_8\}$  and so are metabelian. Therefore by Lemma 3.5, the group  $G/N$  must contain a subgroup  $K$  isomorphic to  $S_3$ .

Moreover, such a subgroup in  $G/N$  cannot centralize  $N$ . For if it did, then  $C_G(N)$  (and hence  $G$ ) would have a normal 3-subgroup; but  $G$  is critical and therefore monolithic (it contains a unique minimal normal subgroup, which is a 2-group) [57, 51.32].

An orbit of  $K$  on  $N$  has order at most 6, and so generates a subgroup of order at most  $2^6$ . We show there must be such a subgroup of order  $2^2$ . First, consider the action of an element of order 3 in  $K$ ; let  $\{x_1, x_2, x_3\}$  be an orbit. The subgroup  $\langle x_1, x_2, x_3 \rangle$  has order  $2^2$  or  $2^3$ ; in the latter case, the subgroup  $\langle x_1x_2, x_2x_3, x_3x_1 \rangle$  has order  $2^2$ .

If such a subgroup  $\{1, y_1, y_2, y_3\}$  of order  $2^2$  is invariant under an element  $t$  of order 2 in  $K$ , our claim is proved; so suppose not. Let  $z_i = y_i^t$  where  $i = 1, 2, 3$ . Then the group generated by the  $y$ s and  $z$ s has order  $2^4$  and is invariant under  $S_3$ . We can assume that conjugation by an element  $u$  of order 3 in  $K$  induces the permutation  $(y_1, y_2, y_3)(z_1, z_3, z_2)$  (since  $t$  inverts  $u$ ). Then the subgroup  $\langle y_1z_1, y_2z_3, y_3z_2 \rangle$  has order  $2^2$  and is  $S_3$ -invariant.

Now the group generated by  $K$  together with this  $K$ -invariant subgroup of  $N$  is isomorphic to  $S_4$ , and belongs to  $\text{var}\{G\}$ . So  $\text{var}\{S_4\} \subseteq \text{var}\{G\}$ , and we have equality as required.  $\square$

**Corollary 3.7.** *Any proper subvariety of  $\text{var}\{S_4\}$  is metabelian.*

The analogous result for  $\text{SL}(2, 3)$  is similar but easier to establish. We have noted in Subsection 3.3 that the identities of  $\text{SL}(2, 3)$  have the form  $[\mathbf{w}, x] \approx \mathbf{w}^2 \approx 1$ , where  $\mathbf{w} \approx 1$  ranges over the identities of  $A_4$  and  $x$  is a variable not in  $\mathbf{w}$ .

**Theorem 3.8.** *Let  $G$  be any critical group in  $\text{var}\{\text{SL}(2, 3)\}$  that is not metabelian. Then  $\text{var}\{G\} = \text{var}\{\text{SL}(2, 3)\}$ .*

*Proof.* The preliminary result, that a non-abelian group in  $\text{var}\{A_4\}$  contains a subgroup isomorphic to  $A_4$ , is proved similarly to the analogous result for  $S_3$ .

Now let  $G \in \text{var}\{\text{SL}(2, 3)\}$  and suppose that  $G$  is critical and not metabelian. Then  $G''$  is an elementary abelian 2-group and is contained in  $Z(G)$ , so all its subgroups are normal in  $G$ . Since  $G$  is monolithic, we find that  $|G''| = 2$ .

Now  $G/G''$  has a subgroup isomorphic to  $A_4$ , and it is easy to see that this lifts to a subgroup of  $G$  isomorphic to  $SL(2, 3)$ .  $\square$

**Corollary 3.9.** *Any proper subvariety of  $\text{var}\{SL(2, 3)\}$  is metabelian.*

### 3.6 Small groups

We now demonstrate that we have covered all groups of order smaller than 24. We have seen that identity bases for abelian groups are trivial. The remaining groups are metabelian, and in most cases Higman's theorem applies. We note, for example, that the two non-abelian groups of order 8 (the dihedral and quaternion groups) generate the same variety (see [57, 54.23]).

The outstanding cases are the three groups of order 16 whose derived subgroups are cyclic of order 4; these are

- the *dihedral group*  $D_{16} = \langle a, b \mid a^8 = b^2 = 1, b^{-1}ab = a^{-1} \rangle$ ;
- the *semi-dihedral group*  $SD_{16} = \langle x, y \mid x^8 = y^2 = 1, y^{-1}xy = x^3 \rangle$ ;
- the *generalized quaternion group*  $Q_{16} = \langle p, q \mid p^8 = 1, q^2 = p^4, q^{-1}pq = p^{-1} \rangle$ .

We sketch a proof that all three generate the same variety (whose description follows from [27], see Theorem 3.4).

Take two copies of the dihedral group, the second generated by elements  $c$  and  $d$  satisfying the same relations as  $a$  and  $b$ ; let  $G$  be the *central product* of these two groups (the quotient by the central subgroup generated by  $a^4c^4$ ). Now  $D_{16}$  is a subgroup of  $G$ , and  $G$  is a quotient of a product of two copies of  $D_{16}$ , so that  $\text{var}\{D_{16}\} = \text{var}\{G\}$ .

Now we can find copies of the other two groups in  $G$  as follows:

- $Q_{16} = \langle p, q \rangle$ , where  $p = a$  and  $q = bc^2$ ;
- $SD_{16} = \langle x, y \rangle$ , where  $x = ac^2$  and  $y = b$ .

Clearly  $q^2 = c^4 = p^4$ , and the other relations of  $Q_{16}$  are clear; and  $y^{-1}xy = a^{-1}c^2 = a^3c^6 = x^3$ , and the other relations of  $SD_{16}$  are clear. So  $\text{var}\{Q_{16}\}$  and  $\text{var}\{SD_{16}\}$  are contained in  $\text{var}\{D_{16}\}$ .

To show equality in the first case, we note that  $G$  has an automorphism  $\phi$  interchanging  $a$  and  $c$  and also  $b$  and  $d$ . The image of  $\langle p, q \rangle$  under  $\phi$  is  $\langle c, a^2d \rangle$ . Now these groups commute, since  $bc^2 \cdot a^2d = c^2a^{-2}bd$  while  $a^2d \cdot bc^2 = a^2c^{-2}bd$ , and we have  $c^2a^{-2} = a^2c^{-2}$  since  $a^4 = b^4$ . Moreover, it is easy to see that they are distinct. So they generate their central product, which is  $G$ . Thus  $G$ , and hence  $D_{16}$ , belongs to  $\text{var}\{Q_{16}\}$ .

The same method does not work for the second case, since the two copies of  $SD_{16}$  in  $G$  do not commute; so we reverse the argument. Take two copies of  $SD_{16}$ , generated by  $x, y$  and  $z, w$  respectively, and let  $H$  be their central product (the quotient of the direct product by  $\langle x^4 z^4 \rangle$ ). Put  $a = xz^2$  and  $b = y$ . Then  $a^8 = b^2 = 1$  and

$$b^{-1}ab = y^{-1}xz^2y = x^3z^2 = x^7z^{-2} = (xz^2)^{-1},$$

so that  $\langle a, b \rangle$  is isomorphic to  $D_{16}$ . Therefore  $D_{16}$  is a subgroup of  $H$ , so that  $\text{var}\{D_{16}\} \subseteq \text{var}\{H\} = \text{var}\{SD_{16}\}$ , whence we have equality.

### 3.7 Toward an explicit bound

It follows from Theorem 3.3—the Oates–Powell Theorem—that the variety generated by a finite group is finitely based and small. Can explicit bounds for the orders of critical groups in such a variety be extracted from the proof of this result?

The proof of the Oates–Powell Theorem rests on three lemmas, of which the third concerns the class  $\mathbf{C}(e, m, c)$  of finite groups  $G$  such that

- $G$  has exponent dividing  $e$ ;
- the order of any chief factor of  $G$  is at most  $m$ ;
- the nilpotency class of any nilpotent factor of  $G$  is at most  $c$ .

Then  $\mathbf{C}(e, m, c)$  is a class of finite groups in a variety, whence if  $G \in \mathbf{C}(e, m, c)$ , then every critical group in  $\text{var}\{G\}$  belongs to  $\mathbf{C}(e, m, c)$ .

**Lemma 3.10** (H. Neumann [57, 52.23]). *The class  $\mathbf{C}(e, m, c)$  contains only finitely many critical groups up to isomorphism.*

**Lemma 3.11** (H. Neumann [57, 52.5]). *If  $G \in \mathbf{C}(e, m, c)$  is critical and has non-abelian monolith, then  $|G| \leq m!$ .*

The abelian monolith case is much harder. Neumann [57] says:

If a bound for the index of  $\Phi(G)$  in  $G$  is found, then a bound for  $|G|$  can be derived. For, since  $\Phi(G)$  consists of all non-generators of  $G$ , the number of elements needed to generate  $G$  can be at most  $|G/\Phi(G)|$ . But from bounds for the number of generators of  $G$  and the index of  $\Phi(G)$  in  $G$ , one obtains a bound for the number of generators of  $\Phi(G)$  by means of Schreier’s formula. As  $\Phi(G)$  is nilpotent, of class at most  $c$  and exponent dividing  $e$ , this leads to a bound for the order of  $\Phi(G)$ , and so for the order of  $G$ .

Suppose that we can show that  $|G/\Phi(G)| \leq b$ . Then  $G$  has at most  $\log_2 b$  generators, so our bound for the number of generators of  $\Phi(G)$  is  $1 + (b - 1)\log_2 b$ , or in broad brush terms,  $d \leq b \log b$ . This gives a bound for the order of  $\Phi(G)$  which is roughly  $e^{d+d^2+\dots+d^c}$ , since the lower central factors are generated by commutators.

A small improvement is possible. If  $\Phi(G)$  is not a  $p$ -group, then it is the direct product of its Sylow  $p$ -subgroups, each of which contains a nontrivial normal subgroup of  $G$ , contradicting the fact that  $G$  is monolithic. So we can replace  $e$  in the above bound by the largest prime divisor of  $e$ .

Continuing, the proof considers a series

$$\Phi(G) < F < C < G,$$

and shows that  $|G/C| \leq (m!)^c$  and  $|F/\Phi(G)| \leq m^c$ , while  $|C/F| \leq (m!)^t$ , where  $t \leq 1 + ce(m!)$ . The bound for  $b$  is the product of these numbers.

Even for very moderate values of  $e$ ,  $m$ , and  $c$ , the resulting bound is going to be rather large!

## 4 The database of varieties generated by small semigroups

### 4.1 Varieties generated by a semigroup of order up to 5

We produce a database containing all varieties generated by a semigroup of order up to 5 and provide their identity bases. All the proofs concerning semigroups up to order 4 appear (or are referred to) in this paper. The proofs regarding semigroups of order 5 will be published elsewhere.

### 4.2 Non-finitely based varieties generated by a semigroup of order 6

Every variety generated by a semigroup of order up to 5 is finitely based [40, 81, 83]. Among all varieties generated by a semigroup of order 6, precisely four are non-finitely based [43, 48]; these varieties are generated by the following semigroups:

- the monoid  $B_2^1$  obtained from the Brandt semigroup

$$B_2 = \langle a, b \mid a^2 = b^2 = 0, aba = a, bab = b \rangle = \{0, a, b, ab, ba\};$$

$n$	Number of semi-groups of order $n$ , up to equivalence	Number of semi-groups of order $n$ , up to isomorphism	Number of varieties with a primitive generator of order $n$
1	1	1	1
2	4	5	5
3	18	24	14
4	126	188	53
5	1,160	1,915	145
6	15,973	28,634	At least 463
7	836,021	1,627,672	Unknown
8	1,843,120,128	3,684,030,417	Unknown
9	52,989,400,714,478	105,978,177,936,292	Unknown

Table 4: Some numerical data

- the monoid  $A_2^1$  obtained from the 0-simple semigroup

$$A_2 = \langle a, b \mid a^2 = aba = a, bab = b, b^2 = 0 \rangle = \{0, a, b, ab, ba\};$$

- the semigroup  $A_2^g$  obtained by adjoining a new element  $g$  to  $A_2$  with  $g^2 = 0$  and  $gA_2 = A_2g = \{g\}$ ;
- the  $\mathcal{J}$ -trivial semigroup

$$L_3 = \langle a, b \mid a^2 = a, b^2 = b, aba = 0 \rangle = \{0, a, b, ab, ba, bab\}.$$

The Cayley tables of these semigroups are given in Table 5; refer to Lee *et al.* [44] for more historical information on their discovery.

Besides the four non-finitely based semigroups of order six, many other non-finitely based finite semigroups have been discovered since the 1970s; see the survey by Volkov [90]. But explicit identity bases have not been found for varieties generated by most of these semigroups because the task is neither necessary (in establishing the non-finite basis property) nor trivial. Nevertheless, explicit identity bases are available for a few non-finitely based varieties.

**Proposition 4.1** (Jackson [24, Proposition 4.1]). *The identities*

$$x^4 \approx x^3, \quad x^3y \approx yx^3, \quad x^2yx \approx x^3y, \quad xyx^2 \approx x^3y, \quad xyxzx \approx x^3yz,$$

$$\left( \prod_{i=1}^m x_i \right) \left( \prod_{i=m}^1 x_i \right) y^2 \approx y^2 \left( \prod_{i=1}^m x_i \right) \left( \prod_{i=m}^1 x_i \right), \quad m = 1, 2, 3, \dots$$

*constitute an identity basis for a non-finitely based variety generated by a certain semigroup of order 211.*

$B_2^1$	1 2 3 4 5 6	$A_2^1$	1 2 3 4 5 6
1	1 1 1 1 1 1	1	1 1 1 1 1 1
2	1 1 1 2 2 3	2	1 1 1 2 2 3
3	1 2 3 1 3 1	3	1 2 3 2 3 3
4	1 1 1 4 4 6	4	1 1 1 4 4 6
5	1 2 3 4 5 6	5	1 2 3 4 5 6
6	1 4 6 1 6 1	6	1 4 6 4 6 6
$A_2^g$	1 2 3 4 5 6	$L_3$	1 2 3 4 5 6
1	1 1 1 1 1 6	1	1 1 1 1 1 1
2	1 1 1 2 3 6	2	1 1 1 1 1 2
3	1 2 3 2 3 6	3	1 1 1 1 1 3
4	1 1 1 4 5 6	4	1 1 2 1 4 2
5	1 4 5 4 5 6	5	1 1 3 1 5 3
6	6 6 6 6 6 1	6	1 2 2 4 4 6

Table 5: Non-finitely based semigroups of order 6

**Proposition 4.2** (Lee and Volkov [47, Section 1]). *For each  $n \geq 2$ , the identities*

$$x^{n+2} \approx x^2, \quad (xy)^{n+1}x \approx xyx, \quad yxzx \approx xzxyx,$$

$$\left(\prod_{i=1}^m x_i^n\right)^3 \approx \left(\prod_{i=1}^m x_i^n\right)^2, \quad m = 2, 3, 4, \dots$$

*constitute an identity basis for the non-finitely based variety  $\text{var}\{A_2, \mathbb{Z}_n\}$ . In particular,  $\text{var}\{A_2, \mathbb{Z}_2\} = \text{var}\{A_2^g\}$ .*

**Proposition 4.3** (Lee [41, Corollary 3.5]). *For each  $n \geq 1$ , the identities*

$$x^{n+2} \approx x^2, \quad x^{n+1}yx^{n+1} \approx xyx, \quad xhykxty \approx yhxkytx,$$

$$x\left(\prod_{i=1}^m (y_i h_i y_i)\right)x \approx x\left(\prod_{i=m}^1 (y_i h_i y_i)\right)x, \quad m = 2, 3, 4, \dots$$

*constitute an identity basis for the non-finitely based variety  $\text{var}\{L_3, \mathbb{Z}_n\}$ .*

### 4.3 Inherently non-finitely based finite semigroups

The *finite basis problem*—first posed by Tarski [76] in the 1960s as a decision problem—questions which finite algebras are finitely based. This problem is undecidable for general algebras [52] but remains open for finite semigroups.

In contrast, it is decidable if a finite semigroup  $S$  is *inherently non-finitely based* in the sense that every locally finite variety containing  $S$  is non-finitely based. This result follows from the work of Sapir [63, 64], a description of which requires the following concepts:

- the *period* of a semigroup  $S$  is the least number  $d$  such that  $S$  satisfies the identity  $x^{m+d} \approx x^m$  for some  $m \geq 1$ ;
- the *upper hypercenter* of a group  $G$ , denoted by  $\Gamma(G)$ , is the last term in the upper central series of  $G$ ;
- a word  $\mathbf{w}$  is an *isoterm* for a semigroup  $S$  if  $S$  violates every nontrivial identity of the form  $\mathbf{w} \approx \mathbf{w}'$ ;
- the *Zimin words*  $\mathbf{z}_1, \mathbf{z}_2, \mathbf{z}_3, \dots$  are words over the variables  $\{x_1, x_2, x_3, \dots\}$  defined inductively by  $\mathbf{z}_1 = x_1$  and  $\mathbf{z}_{k+1} = \mathbf{z}_k x_{k+1} \mathbf{z}_k$  for each  $k \geq 1$ .

**Theorem 4.4** (Sapir [66, Theorem 3.6.34]). (i) *A finite semigroup  $S$  is inherently non-finitely based if and only if there exists some idempotent  $e \in S$  such that the submonoid  $eSe$  of  $S$  is inherently non-finitely based.*

(ii) *A finite monoid  $M$  with period  $d$  is inherently non-finitely based if and only if there exist  $a \in M$  and an idempotent  $e \in MaM$  such that the elements  $eae$  and  $ea^{d+1}e$  do not belong to the same coset of the maximal subgroup  $M_e$  of  $M$  containing  $e$  with respect to the upper hypercenter  $\Gamma(M_e)$ .*

(iii) *A finite semigroup  $S$  is inherently non-finitely based if and only if the Zimin words  $\mathbf{z}_1, \mathbf{z}_2, \dots, \mathbf{z}_m$ , where  $m = |S|^3$ , are isoterms for  $S$ .*

The non-finitely based semigroups  $A_2^g$  and  $L_3$  are not inherently non-finitely based because they satisfy the identities  $\mathbf{z}_2 \approx x_1(x_2x_1)^3$  and  $\mathbf{z}_2 \approx x_1x_2x_1^2$ , respectively. On the other hand, the semigroups  $A_2^1$  and  $B_2^1$  are inherently non-finitely based since all Zimin words are isoterms [64, Lemma 3.7]. It follows that a finite semigroup  $S$  is inherently non-finitely based if either  $A_2^1 \in \text{var}\{S\}$  or  $B_2^1 \in \text{var}\{S\}$ . Observe that the condition in Theorem 4.4(ii) can hold in a trivial way, namely when  $eae$  or  $ea^{d+1}e$  does not belong to  $M_e$ , so that both elements do not belong to the same coset of  $M_e$ . This is the case for  $B_2^1$ ; see, for example, Volkov and Gol'berg [92, observation after Proposition 1].

For certain finite monoids  $M$ , the condition  $B_2^1 \in \text{var}\{M\}$  is not only sufficient, but also necessary for  $M$  to be inherently non-finitely based.

**Lemma 4.5.** *Let  $M$  be any finite monoid that satisfies the identity  $x^{2n} \approx x^n$  for some  $n \geq 2$ . Suppose that  $M$  satisfies at least one of the following four conditions:  $|M| \leq 55$ ,  $M$  is regular, the idempotents of  $M$  form a submonoid, and all subgroups of  $M$  are nilpotent. Then the following conditions are equivalent:*

- (a)  $M$  is inherently non-finitely based;
- (b)  $B_2^1 \in \text{var}\{M\}$ ;
- (c)  $M$  violates the identity

$$((xy)^n(yx)^n(xy)^n)^n \approx (xy)^n. \quad (4.1)$$

*Proof.* (a)  $\Leftrightarrow$  (b): This holds by Jackson [23, Theorems 1.4 and 2.2] and Sapir [63, Theorem 2].

(c)  $\Rightarrow$  (b): If  $M$  violates the identity (4.1), then  $B_2 \in \text{var}\{M\}$  by Sapir and Suhanov [67, Theorem 1], so that  $B_2^1 \in \text{var}\{M\}$  by Jackson [25, Lemma 1.1].

(b)  $\Rightarrow$  (c): It is routinely verified that  $B_2^1$  violates the identity (4.1). Therefore if  $M$  satisfies the identity (4.1), then  $B_2^1 \notin \text{var}\{M\}$ .  $\square$

There is yet another method to check if a finite monoid is inherently non-finitely based. For each  $n \geq 2$ , define the words  $[x, y]_1^n, [x, y]_2^n, [x, y]_3^n, \dots$  over  $\{x, y\}$  inductively by  $[x, y]_1^n = x^{n-1}y^{n-1}xy$  and  $[x, y]_{k+1}^n = [[x, y]_k^n, y]_1^n$  for each  $k \geq 1$ . Then for any variety  $\mathbf{V}$  generated by a finite semigroup that satisfies the identity  $x^{2n} \approx x^n$ , the subsequence  $\{[x, y]_{k!}^n\}$  converges in the  $\mathbf{V}$ -free semigroup over  $\{x, y\}$ ; let  $[x, y]_\infty^n$  denote the limit of this subsequence [89, Subsection 4.4].

**Lemma 4.6** (Volkov [89, Proposition 4.4]). *Let  $M$  be any finite monoid that satisfies the identity  $x^{2n} \approx x^n$  for some  $n \geq 2$ . Then  $M$  is inherently non-finitely based if and only if it violates either (4.1) or*

$$[eze, (eye)^{n-1}ey^{n+1}e]_\infty^n \approx e \quad \text{with } e = (xyzt)^n.$$

The companion website checks if an input finite semigroup  $S$  is inherently non-finitely based in the following manner. Suppose that  $e_1, e_2, \dots, e_r$  are all the idempotents of  $S$ . Then by Theorem 4.4(i), it suffices to check if some submonoid  $M_i = e_i S e_i$  of  $S$  is inherently non-finitely based; this can be achieved by applying Theorem 4.4(ii). As this is the most general result, the website can handle semigroups of order higher than 55; if the semigroup is inherently non-finitely based, then the website provides the relevant information such as the hypercenter. The website also allows the

user to check if a semigroup is inherently non-finitely based with Lemma 4.5. Results on isotermis are computationally demanding and hence are not used by us.

We refer to the surveys by Volkov [89, 90] for more information on inherently non-finitely based semigroups and the finite basis problem for finite semigroups in general.

Based on results in this subsection, a description of inherently non-finitely based semigroups of order up to 9 is possible. For this purpose, the semigroup  $A_2^1$  and  $B_2^1$ , together with those given in Tables 6–8, are required.

$U_7$	1	2	3	4	5	6	7	$V_7$	1	2	3	4	5	6	7	$W_7$	1	2	3	4	5	6	7
1	1	1	1	1	1	1	1	1	1	1	1	1	1	1	1	1	1	1	1	5	5	5	
2	1	1	1	1	2	2	3	2	1	1	1	1	2	2	3	2	1	2	1	2	5	5	7
3	1	2	3	1	1	3	1	3	1	2	3	1	2	3	3	3	1	1	3	3	5	6	5
4	4	4	4	4	4	4	4	4	4	4	4	4	4	4	4	4	1	2	3	4	5	6	7
5	4	4	4	4	5	5	7	5	4	4	4	4	5	5	7	5	5	5	5	5	1	1	1
6	1	2	3	4	5	6	7	6	1	2	3	4	5	6	7	6	5	6	5	6	1	1	3
7	4	5	7	4	4	7	4	7	4	5	7	4	5	7	7	7	5	5	7	7	1	2	1

Table 6: The semigroups  $U_7$ ,  $V_7$ , and  $W_7$

$U_8$	1	2	3	4	5	6	7	8	$V_8$	1	2	3	4	5	6	7	8
1	1	1	1	1	1	1	1	1	1	1	1	1	5	5	7	7	
2	1	1	1	1	2	2	3	4	2	1	2	1	2	5	5	7	8
3	1	2	3	4	3	4	4	4	3	1	1	3	3	5	6	7	7
4	4	4	4	4	4	4	4	4	4	1	2	3	4	5	6	7	8
5	1	2	3	4	5	6	7	8	5	5	5	5	5	7	7	1	1
6	4	4	4	4	6	6	7	8	6	5	6	5	6	7	7	1	3
7	4	6	7	8	7	8	8	8	7	7	7	7	7	1	1	5	5
8	8	8	8	8	8	8	8	8	8	7	7	8	8	1	2	5	5

Table 7: The semigroups  $U_8$  and  $V_8$

Since the semigroups in Tables 6–8 are monoids, it is routinely checked by Lemma 4.5 that they are all inherently non-finitely based. With the exception of  $U_7$ ,  $V_7$  and  $U_8$ , each of these semigroups is isomorphic to its dual.

**Proposition 4.7.** *Let  $S$  be any inherently non-finitely based semigroup of order 9 or less.*

- (i) *If  $|S| \leq 6$ , then  $S$  is isomorphic to one of the semigroups  $A_2^1$  and  $B_2^1$ .*

$U_9$	1	2	3	4	5	6	7	8	9	$V_9$	1	2	3	4	5	6	7	8	9
1	1	1	1	1	1	1	1	1	1	1	1	1	1	1	6	6	6	6	6
2	1	1	1	1	1	2	2	3	4	2	1	1	1	2	2	6	6	6	7
3	1	2	3	4	4	3	4	4	4	3	3	3	3	3	3	8	8	8	8
4	4	4	4	4	4	4	4	4	4	4	1	2	3	4	5	6	7	8	9
5	5	5	5	5	5	5	5	5	5	5	3	3	3	5	5	8	8	8	9
6	1	2	3	4	5	6	7	8	9	6	1	1	1	6	1	6	6	6	6
7	5	5	5	5	5	7	7	8	9	7	1	2	1	7	1	6	7	6	6
8	5	7	8	9	9	8	9	9	9	8	3	3	3	8	3	8	8	8	8
9	9	9	9	9	9	9	9	9	9	9	3	5	3	9	3	8	9	8	8

$W_9$	1	2	3	4	5	6	7	8	9
1	1	1	1	1	1	6	6	6	6
2	1	1	1	2	2	6	6	6	7
3	3	3	3	3	3	8	8	8	8
4	1	2	3	4	5	6	7	8	9
5	3	3	3	5	5	8	8	8	9
6	1	1	1	6	1	6	6	6	6
7	1	2	1	7	2	6	7	6	7
8	3	3	3	8	3	8	8	8	8
9	3	5	3	9	5	8	9	8	9

Table 8: The semigroups  $U_9$ ,  $V_9$ , and  $W_9$

- (ii) *If  $|S| = 7$ , then either  $S$  contains  $A_2^1$  or  $B_2^1$  as a subsemigroup or  $S$  is isomorphic to one of the semigroups  $U_7$ ,  $V_7$ ,  $\overleftarrow{V}_7$ , and  $W_7$ .*
- (iii) *If  $|S| = 8$ , then either  $S$  contains a proper subsemigroup that is inherently non-finitely based or  $S$  is isomorphic to one of the semigroups  $U_8$ ,  $\overleftarrow{U}_8$ , and  $V_8$ .*
- (iv) *If  $|S| = 9$  and  $S$  satisfies the identity  $x^4 \approx x^2$ , then either  $S$  contains a proper subsemigroup that is inherently non-finitely based or  $S$  is isomorphic to one of the semigroups  $U_9$ ,  $\overleftarrow{U}_9$ ,  $V_9$ , and  $W_9$ .*

It is long and well known that the semigroups  $A_2^1$  and  $B_2^1$  of order 6 are the smallest inherently non-finitely based semigroups. The GAP package SmallSemi contains all the semigroups of order up to 8 and hence we could routinely run the algorithm outlined after Lemma 4.6.

To find inherently non-finitely based semigroups of order 9, we used the following algorithm (which in fact uses different results and computations to double check Proposition 4.7 parts (ii) and (iii)):

- (a) Use Mace4 [99] to generate all monoids of orders 6–9 that satisfy the identity  $x^4 \approx x^2$  but violate the identity (4.1), thus resorting to Lemma 4.5; this led to 457,745 semigroups.
- (b) Use Isofilter to discard isomorphic copies; this led to 7,625 semigroups which are all inherently non-finitely based, but many of which contain proper subsemigroups that are inherently non-finitely based.
- (c) Use GAP's SmallSemi to discard the semigroups of order  $n \in \{7, 8, 9\}$  that contain a proper subsemigroup that is inherently non-finitely based; this left us with the semigroups in Tables 6–8.

CHAPTER 1 - INTRODUCTION

**GAP Smallsemi:**

Order: 5      Sequence: 67

Semigroup Variety      Cayley to Presentation

The semigroup you entered: **S =** [11111, 11111, 11111, 11111, 11115]      Gap      Cooked

Isomorphism class rep. (min.lex.) of **S** [11111, 11111, 11111, 11111, 11115]      Gap      Cooked

The variety  $\text{var}\{S\}$  coincides with  $V(3, 2)$

Identity basis  $x^2a \approx xa, xy \approx yx$       Prover9

Primitive generator [111, 111, 113]

Common generator none

Prime decomposition  $V(2,1) \vee V(2,2) = \text{var}\{N_2\} \vee \text{var}\{S\ell_2\}$

Identities defining maximal subvarieties (1)  $x^2 \approx x$

(2)  $x^2 \approx xy$

Maximal subvarieties (1)  $V(3, 2) \cap [x^2 \approx x] = V(2, 2) = \text{var}\{S\ell_2\}$

(2)  $V(3, 2) \cap [x^2 \approx xy] = V(2, 1) = \text{var}\{N_2\}$

Other information on  $V(3, 2)$  Self-dual

Cross with 4 subvarieties

References T. Evans, The lattice of semigroup varieties, Semigroup Forum 2 (1971), no. 1, 1–43. Figure 3.

Semilattice decomposition

H-Classes [5], GAP Id(1,1)

Epigroup identities  $(x * y) * z = x * (y * z), x * x' = x' * x, x' = (x' * x) * x', ((x * (x * x))) * x' = x * x.$

Epigroup unary operation

	0	1	2	3	4
'	0	0	0	0	4

Some inclusions of varieties

Containing varieties

Subvarieties

Solid line: lower variety is a maximal subvariety of the upper one

Figure 5: Companion website: example of information displayed if the identity basis for the variety generated by the given semigroup is found

**Multiplication table:**

333 123 333

Semigroup Variety    Cayley to Presentation

**The semigroup you entered: S =**    [333, 123, 333]    Gap    Cooked

**Isomorphism class rep. (min.lex.) of S**    [111, 111, 123]    Gap    Cooked

Figure 6: Companion website: computation of the smallest element in the isomorphism class of [333,123,333]

Variety	Primitive Generator	Identity Basis	Common Generator	# max. subvar.									
V(3,1)	<table border="1"> <tr><td>1</td><td>1</td><td>1</td></tr> <tr><td>1</td><td>1</td><td>1</td></tr> <tr><td>1</td><td>1</td><td>2</td></tr> </table>	1	1	1	1	1	1	1	1	2	$x^3 \approx xyz$ $xy \approx yx$	$N_3 = \langle a \mid a^3 = 0 \rangle = \{0, a, a^2\}$	1
1	1	1											
1	1	1											
1	1	2											
V(3,2)	<table border="1"> <tr><td>1</td><td>1</td><td>1</td></tr> <tr><td>1</td><td>1</td><td>1</td></tr> <tr><td>1</td><td>1</td><td>3</td></tr> </table>	1	1	1	1	1	1	1	1	3	$x^2a \approx xa$ $xy \approx yx$	none	2
1	1	1											
1	1	1											
1	1	3											
V(3,3)	<table border="1"> <tr><td>1</td><td>1</td><td>1</td></tr> <tr><td>1</td><td>1</td><td>1</td></tr> <tr><td>1</td><td>2</td><td>3</td></tr> </table>	1	1	1	1	1	1	1	2	3	$x^2a \approx xa$ $xy^2 \approx yx^2$	$J = \langle a, e \mid ae=0, ea=a, e^2=e \rangle = \{0, a, e\}$	1
1	1	1											
1	1	1											
1	2	3											

Figure 7: Companion website: varieties V(3,1), V(3,2), and V(3,3) in the database

**Multiplication table:**

11145 11245 12345 11445 14545

Semigroup Variety    Cayley to Presentation

<b>The semigroup you entered: S =</b>	[11145, 11245, 12345, 11445, 14545]    Gap    Cooked
<b>Isomorphism class rep. (min.lex.) of S</b>	[11145, 11245, 12345, 11445, 14545]    Gap    Cooked
<b>The variety <math>\text{var}\{S\}</math> coincides with</b>	V(5, 141)
<b>Identity basis</b>	$x^3 \approx x^2, x^2yx \approx xyx, xyx^2 \approx yx^2, xyxy \approx yx^2y, xyaxy \approx yxaxy,$ $xyxay \approx yx^2ay, xyxby \approx yxaby$ Prover9
<b>Primitive generator</b>	[11145, 11245, 12345, 11445, 14545]
<b>Common generator</b>	$\overleftarrow{P}_2^1 = \langle a, e \mid ea^2 = a^2, e^2 = ae = e \rangle \cup \{1\} = \{a, e, a^2, ea, 1\}$

Figure 8: Companion website: example of a presentation provided

**Presentation:**

Theory (or choose example below) Relations (or choose example below)

$x^*(y^*z)=(x^*y)^*z.$   $c^*c=c, l^*l=l, m^*m=m, c^*(l^*c)=l^*c,$   
 $l^*(c^*)=l^*c, c^*(m^*c)=m^*c,$   
 $m^*(c^*m)=m^*c, l^*(m^*l)=m^*l, m^*(l^*m)=m^*l.$

The semigroup you entered: **S**

*	c	l	m	c <sup>*</sup> l	c <sup>*</sup> m	l <sup>*</sup> c	l <sup>*</sup> m	m <sup>*</sup> c	m <sup>*</sup> l	c <sup>*</sup> (l <sup>*</sup> m)	c <sup>*</sup> (m <sup>*</sup> l)	l <sup>*</sup> (c <sup>*</sup> m)	l <sup>*</sup> (m <sup>*</sup> c)	m <sup>*</sup> (c <sup>*</sup> l)	m <sup>*</sup> (l <sup>*</sup> c)	l <sup>*</sup> (c <sup>*</sup> (m <sup>*</sup> l))	l <sup>*</sup> (m <sup>*</sup> (c <sup>*</sup> l))
c	c	c <sup>*</sup> l	c <sup>*</sup> m	c <sup>*</sup> l	c <sup>*</sup> m	l <sup>*</sup> c	c <sup>*</sup> (l <sup>*</sup> m)	m <sup>*</sup> c	c <sup>*</sup> (m <sup>*</sup> l)	c <sup>*</sup> (l <sup>*</sup> m)	c <sup>*</sup> (m <sup>*</sup> l)	l <sup>*</sup> (c <sup>*</sup> m)	l <sup>*</sup> (m <sup>*</sup> c)	m <sup>*</sup> (c <sup>*</sup> l)	m <sup>*</sup> (l <sup>*</sup> c)	l <sup>*</sup> (c <sup>*</sup> (m <sup>*</sup> l))	l <sup>*</sup> (m <sup>*</sup> (c <sup>*</sup> l))
l	l <sup>*</sup> c	l	l <sup>*</sup> m	l <sup>*</sup> c	l <sup>*</sup> (c <sup>*</sup> m)	l <sup>*</sup> c	l <sup>*</sup> m	l <sup>*</sup> (m <sup>*</sup> c)	m <sup>*</sup> l	l <sup>*</sup> (c <sup>*</sup> m)	l <sup>*</sup> (m <sup>*</sup> l)	l <sup>*</sup> (c <sup>*</sup> m)	l <sup>*</sup> (m <sup>*</sup> c)	m <sup>*</sup> (c <sup>*</sup> l)	m <sup>*</sup> (l <sup>*</sup> c)	l <sup>*</sup> (c <sup>*</sup> (m <sup>*</sup> l))	l <sup>*</sup> (m <sup>*</sup> (c <sup>*</sup> l))
m	m <sup>*</sup> c	m <sup>*</sup> l	m	m <sup>*</sup> (c <sup>*</sup> l)	m <sup>*</sup> c	m <sup>*</sup> (l <sup>*</sup> c)	m <sup>*</sup> l	m <sup>*</sup> c	m <sup>*</sup> l	m <sup>*</sup> (c <sup>*</sup> l)	m <sup>*</sup> (m <sup>*</sup> l)	l <sup>*</sup> (c <sup>*</sup> m)	l <sup>*</sup> (m <sup>*</sup> c)	m <sup>*</sup> (c <sup>*</sup> l)	m <sup>*</sup> (l <sup>*</sup> c)	l <sup>*</sup> (c <sup>*</sup> (m <sup>*</sup> l))	l <sup>*</sup> (m <sup>*</sup> (c <sup>*</sup> l))
c <sup>*</sup> l	l <sup>*</sup> c	c <sup>*</sup> l	c <sup>*</sup> (l <sup>*</sup> m)	l <sup>*</sup> c	l <sup>*</sup> (c <sup>*</sup> m)	l <sup>*</sup> c	c <sup>*</sup> (l <sup>*</sup> m)	l <sup>*</sup> (m <sup>*</sup> c)	c <sup>*</sup> (m <sup>*</sup> l)	l <sup>*</sup> (c <sup>*</sup> m)	l <sup>*</sup> (m <sup>*</sup> l)	l <sup>*</sup> (c <sup>*</sup> m)	l <sup>*</sup> (m <sup>*</sup> c)	m <sup>*</sup> (c <sup>*</sup> l)	m <sup>*</sup> (l <sup>*</sup> c)	l <sup>*</sup> (c <sup>*</sup> (m <sup>*</sup> l))	l <sup>*</sup> (m <sup>*</sup> (c <sup>*</sup> l))
c <sup>*</sup> m	m <sup>*</sup> c	c <sup>*</sup> (m <sup>*</sup> l)	c <sup>*</sup> m	m <sup>*</sup> (c <sup>*</sup> l)	m <sup>*</sup> c	m <sup>*</sup> (l <sup>*</sup> c)	c <sup>*</sup> (m <sup>*</sup> l)	m <sup>*</sup> c	c <sup>*</sup> (m <sup>*</sup> l)	m <sup>*</sup> (c <sup>*</sup> l)	m <sup>*</sup> (m <sup>*</sup> l)	l <sup>*</sup> (c <sup>*</sup> m)	l <sup>*</sup> (m <sup>*</sup> c)	m <sup>*</sup> (c <sup>*</sup> l)	m <sup>*</sup> (l <sup>*</sup> c)	l <sup>*</sup> (c <sup>*</sup> (m <sup>*</sup> l))	l <sup>*</sup> (m <sup>*</sup> (c <sup>*</sup> l))
l <sup>*</sup> c	l <sup>*</sup> c	l <sup>*</sup> c	l <sup>*</sup> (c <sup>*</sup> m)	l <sup>*</sup> c	l <sup>*</sup> (c <sup>*</sup> m)	l <sup>*</sup> c	l <sup>*</sup> (c <sup>*</sup> m)	l <sup>*</sup> (m <sup>*</sup> c)	l <sup>*</sup> (c <sup>*</sup> m)	l <sup>*</sup> (c <sup>*</sup> m)	l <sup>*</sup> (m <sup>*</sup> l)	l <sup>*</sup> (c <sup>*</sup> m)	l <sup>*</sup> (m <sup>*</sup> c)	m <sup>*</sup> (c <sup>*</sup> l)	m <sup>*</sup> (l <sup>*</sup> c)	l <sup>*</sup> (c <sup>*</sup> (m <sup>*</sup> l))	l <sup>*</sup> (m <sup>*</sup> (c <sup>*</sup> l))

...

m <sup>*</sup> (l <sup>*</sup> c)	m <sup>*</sup> (l <sup>*</sup> c)	m <sup>*</sup> (l <sup>*</sup> c)	m <sup>*</sup> (l <sup>*</sup> c)	m <sup>*</sup> (l <sup>*</sup> c)	m <sup>*</sup> (l <sup>*</sup> c)	m <sup>*</sup> (l <sup>*</sup> c)	m <sup>*</sup> (l <sup>*</sup> c)	m <sup>*</sup> (l <sup>*</sup> c)	m <sup>*</sup> (l <sup>*</sup> c)	m <sup>*</sup> (l <sup>*</sup> c)	m <sup>*</sup> (l <sup>*</sup> c)	m <sup>*</sup> (l <sup>*</sup> c)	m <sup>*</sup> (l <sup>*</sup> c)	m <sup>*</sup> (l <sup>*</sup> c)	m <sup>*</sup> (l <sup>*</sup> c)	m <sup>*</sup> (l <sup>*</sup> c)	m <sup>*</sup> (l <sup>*</sup> c)
l <sup>*</sup> (c <sup>*</sup> (m <sup>*</sup> l))	m <sup>*</sup> (l <sup>*</sup> c)	l <sup>*</sup> (c <sup>*</sup> (m <sup>*</sup> l))	l <sup>*</sup> (c <sup>*</sup> (m <sup>*</sup> l))	m <sup>*</sup> (l <sup>*</sup> c)	m <sup>*</sup> (l <sup>*</sup> c)	m <sup>*</sup> (l <sup>*</sup> c)	l <sup>*</sup> (c <sup>*</sup> (m <sup>*</sup> l))	m <sup>*</sup> (l <sup>*</sup> c)	l <sup>*</sup> (c <sup>*</sup> (m <sup>*</sup> l))	m <sup>*</sup> (l <sup>*</sup> c)	m <sup>*</sup> (l <sup>*</sup> c)	m <sup>*</sup> (l <sup>*</sup> c)	m <sup>*</sup> (l <sup>*</sup> c)	m <sup>*</sup> (l <sup>*</sup> c)	m <sup>*</sup> (l <sup>*</sup> c)	m <sup>*</sup> (l <sup>*</sup> c)	m <sup>*</sup> (l <sup>*</sup> c)
l <sup>*</sup> (m <sup>*</sup> (c <sup>*</sup> l))	m <sup>*</sup> (l <sup>*</sup> c)	l <sup>*</sup> (m <sup>*</sup> (c <sup>*</sup> l))	l <sup>*</sup> (m <sup>*</sup> (c <sup>*</sup> l))	m <sup>*</sup> (l <sup>*</sup> c)	m <sup>*</sup> (l <sup>*</sup> c)	m <sup>*</sup> (l <sup>*</sup> c)	l <sup>*</sup> (m <sup>*</sup> (c <sup>*</sup> l))	m <sup>*</sup> (l <sup>*</sup> c)	l <sup>*</sup> (m <sup>*</sup> (c <sup>*</sup> l))	m <sup>*</sup> (l <sup>*</sup> c)	m <sup>*</sup> (l <sup>*</sup> c)	m <sup>*</sup> (l <sup>*</sup> c)	m <sup>*</sup> (l <sup>*</sup> c)	m <sup>*</sup> (l <sup>*</sup> c)	m <sup>*</sup> (l <sup>*</sup> c)	m <sup>*</sup> (l <sup>*</sup> c)	m <sup>*</sup> (l <sup>*</sup> c)

Gap Cooked

**Identity system not found**

**Semilattice decomposition**

Figure 9: Companion website: Kiselman semigroup entered as a presentation

<p><b>Semigroup elements:</b></p> <input type="radio"/> (1..n) <input type="radio"/> (0..n-1) <input type="radio"/> Other	<p><b>Multiplication table:</b></p> <input type="text" value="1, 2, 3, 2, 3, 1, 3, 1, 2"/>
	<input type="text" value="[[ 1, 2, 3 ], [ 2, 3, 1 ], [ 3, 1, 2 ] ]"/>
<p><b>Semigroup elements:</b></p> <input type="radio"/> (1..n) <input type="radio"/> (0..n-1) <input type="radio"/> Other	<p><b>Multiplication table:</b></p> <input type="text" value="012120201"/>
	<input type="text" value="012 120 201"/>
<p><b>Semigroup elements:</b></p> <input type="radio"/> (1..n) <input type="radio"/> (0..n-1) <input type="radio"/> Other <input type="text" value="e a b"/>	<p><b>Multiplication table:</b></p> <input type="text" value="e a b a b e b e a"/>
<p><b>GAP Smallsemi:</b></p> <input type="text" value="Order: 3"/> <input type="text" value="Sequence: 18"/> <input type="button" value="Go!"/>	
<p><b>GAP Smallgroup:</b></p> <input type="text" value="Order: 3"/> <input type="text" value="Sequence: 1"/> <input type="button" value="Go!"/>	
<p><b>The semigroup you entered: S =</b></p>	<input type="text" value="[123, 231, 312]"/>
<p><b>Isomorphism class rep. (min.lex.) of S</b></p>	<input type="text" value="[123, 231, 312]"/>
<p><b>The variety <math>\text{var}\{S\}</math> coincides with</b></p>	<input type="text" value="V(3,14)"/>
<p><b>Identity basis</b></p>	<input type="text" value="x&lt;sup&gt;3&lt;/sup&gt;a ≈ a, xy ≈ yx"/> <input type="button" value="Copy"/>
<p><b>Primitive generator</b></p>	<input type="text" value="[123, 231, 312]"/>
<p><b>Common generator</b></p>	<input type="text" value="Z&lt;sub&gt;3&lt;/sub&gt; = ⟨a   a&lt;sup&gt;3&lt;/sup&gt; = 1⟩ = {a, a&lt;sup&gt;2&lt;/sup&gt;, 1}"/>

Figure 10: Companion website: examples of input alternatives for semigroup [123,231,312]

**The semigroup you entered: S =**

1	1	1	1	5	5	1	1	5	5
1	2	1	1	5	5	1	1	5	5
3	3	3	3	6	6	3	3	6	6
3	3	3	4	6	6	3	3	6	6
1	1	1	1	5	5	5	5	1	1
3	3	3	3	6	6	6	6	3	3
1	1	3	3	5	6	7	8	9	10
1	1	3	3	5	6	8	7	10	9
3	3	1	1	6	5	9	10	8	7
3	3	1	1	6	5	10	9	7	8

Gap    Cooked

---

**Isomorphism class rep. (min.lex.) of S**

1	1	1	1	1	1	7	7	7	7
1	2	1	1	1	1	7	7	7	7
1	1	3	4	4	6	7	8	9	10
4	4	4	4	4	4	8	8	8	8
4	4	4	4	5	4	8	8	8	8
1	1	6	4	4	3	7	8	10	9
1	1	7	1	1	7	7	7	1	1
4	4	8	4	4	8	8	8	4	4
4	4	9	1	1	10	8	7	6	3
4	4	10	1	1	9	8	7	3	6

Gap    Cooked

---

**Identity system not found**

---

**Semilattice decomposition**

```

graph TD
    A([2]) --> D([1,3,5,6] V(4, 48))
    B([4]) --> D
    C([8,9,10,7] V(4, 53)) --> D
    
```

Figure 11: Companion website: example of semilattice decomposition of a order 10 semigroup

We intended to illustrate this feature with the Cayley table of page 201 of [71]. Incidentally, our website found that this structure is not a semigroup: for instance,  $(a \cdot e_2) \cdot f_3 \neq a \cdot (e_2 \cdot f_3)$ .

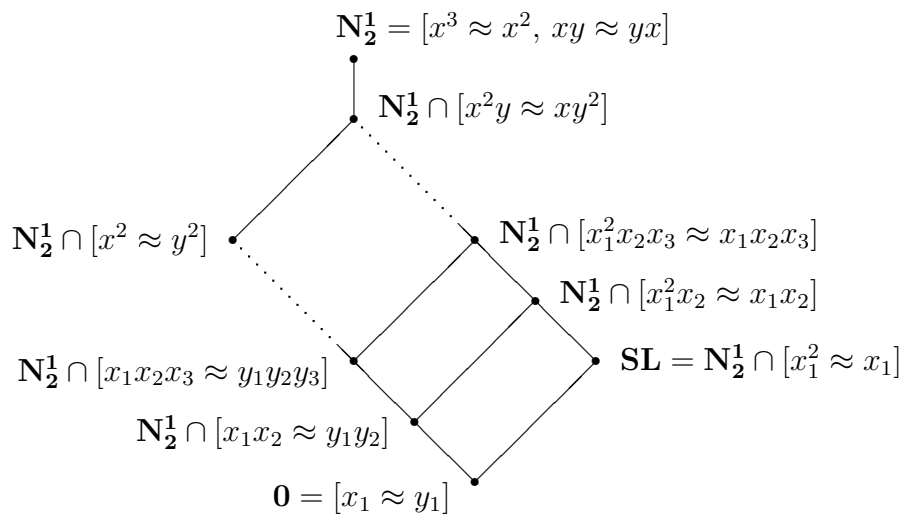

Figure 14: The lattice of subvarieties of  $\mathbf{N}_2^1 = \text{var}\{N_2^1\}$

## 5 The companion webpage

In this section we will give some brief details on the architecture of the website.

### 5.1 Multiplication table

A very flexible data entry tool was developed to allow the input of a multiplication table of a semigroup  $S$ . By default, the elements of the semigroup are assumed to be  $1, 2, \dots, N$ . It is convenient to use the multiplication tables coming from **GAP**. Some other computational tools use the elements  $0, 1, \dots, N - 1$ , and this can also be used, along with sets on different (given) elements.

The entries of the Cayley table can be separated by commas or spaces, and optionally can include `[.]` to bound each line and/or the full multiplication table. If the elements are all single-digit, all or part of the separators can be omitted. For instance, all input strings below can be used as input for the same multiplication table:

---

<code>1 1 1 1 1 1 1 1 2</code>	space separated
<code>1,1,1,1,1,1,1,1,2</code>	comma separated
<code>1, 1, 1, 1, 1, 1, 1, 1, 2</code>	mixed commas and spaces
<code>[1, 1, 1, 1, 1, 1, 1, 1, 2]</code>	“[” and “]” enclosed
<code>[ [ 1, 1, 1 ], [ 1, 1, 1 ], [ 1, 1, 2 ] ]</code>	<b>GAP</b> syntax
<code>111 111 112</code>	separators omitted (for single digit elements)
<code>111111112</code>	separators omitted (for single digit elements)

---

Using the **GAP** syntax option, it is possible to copy a multiplication table from **GAP** and paste it here. For example, we can just copy and paste the output of **GAP** coming from the following command:

```
gap> MultiplicationTable(SmallGroup(5,1));
[[ [ 1, 2, 3, 4, 5 ], [ 2, 3, 4, 5, 1 ], [ 3, 4, 5, 1, 2 ], [ 4, 5, 1, 2, 3 ], [ 5, 1, 2, 3, 4 ] ]]
```

The number of the multiplication table entries must be a perfect square, otherwise an error will be returned. Only semigroups will be accepted, so the associativity property is checked by default.

Semigroups up to order 100 are accepted, but the representative in the

isomorphism class of  $S$ , whose vector  $\vec{v}(S)$  is lexicographically the least, will only be computed in case the order of  $S$  is 10 or less.

## 5.2 Finding the least semigroup of its isomorphism class

Finding the semigroup  $S$  in its isomorphism class whose vector  $\vec{v}(S)$  is the least lexicographically is not necessary to access the main tools available on the website; however, it is much more convenient and an essential part of the way we name varieties.

An obvious algorithm would be to give to some model builder, such as Mace4, the Cayley table of the semigroup and ask for all the isomorphic models in the same underlying set. This gives a list of vectors that we only need to order.

We decided to use our own algorithm that proved to deliver the result for semigroups of order up to 10 in less than a second, and that we now outline.

### 5.2.1 The minlex algorithm

The MINLEX algorithm (page 51) returns the multiplication table of the least (lexicographically) semigroup isomorphic to the given semigroup.

## 5.3 Generating a semigroup from a given presentation

The presentation tool finds the multiplication table from a presentation. One of the distinctive features of this tool is that it allows to define infinitely many different presentations (semigroups, bands, etc.) defined as varieties or quasi-varieties. The presentation (both theory and relations) must be written in Prover9 <sup>1</sup> syntax. A presentation has two ingredients: the theory and some relations between the generators.

To specify the identities that define the theory and the relations, a subset of the Prover9 syntax is used:

- Variables (with names started by “u”, “v”, “w”, “x”, “y” and “z”). No variables will be allowed at the *relations* window;
- Constants (with names started with a 0 – 9,  $a - s$ , or  $A - Z$ );

---

<sup>1</sup>Currently the companion website uses Prover9, the most popular automatic theorem prover. At any time, we can replace it with a more efficient one, keeping the same input syntax.

---

**Algorithm 1** Minlex Algorithm

---

```

1: procedure MINLEX(order, mtable)  ▷ order, mult. table of semigroup
2:   minlex ← mtable
3:   for  $i \leftarrow 1, order$  do
4:     newElem[ $i$ ] ←  $i$ 
5:   end for
6:   for all  $x \in$  order-permutations of order do
7:     for  $i \leftarrow 1, order$  do
8:       newElem[ $x[i]$ ] ←  $i$ 
9:     end for
10:    equal ← True
11:    equal ← False
12:    smaller ← False
13:    if newElem[mtable[ $x[1]$ ][ $x[1]$ ]] = 1 then
14:      for  $l \leftarrow 1, order$  do
15:        for  $c \leftarrow 1, order$  do
16:           $e \leftarrow newElem[mtable[x[1]][x[c]]]$ 
17:           $e0 = minlex[l][c]$ 
18:          if equal = True then
19:            if  $e > e0$  then
20:              stop ← True
21:              Break
22:            else if  $e < e0$  then
23:              equal = False
24:              smaller = True
25:            end if
26:          end if
27:           $a1[l][c] \leftarrow e$ 
28:        end for
29:        if stop = True then
30:          Break
31:        end if
32:      end for
33:    end if
34:    if smaller = True then
35:      minlex ←  $a1$ 
36:    end if
37:  end for
38:  return minlex
39: end procedure

```

---

- Binary operation character \*;
- Equal sign =;
- Parentheses ( and );
- Each identity must end with a final mark.

**Examples:**

Consider the following example presentations, and how to enter the corresponding theory:

Presentation	Theory	Relations
$\langle a, e   ea^2 = a^2, e^2 = ae = e \rangle$ $= \{a, e, a^2, ea\}$	$x * (y * z) = (x * y) * z.$	$(e * a) * a = a * a.$ $e * e = a * e.$ $a * e = e.$
$\langle a   a^5 = 1 \rangle$ $= \{a, a^2, a^3, a^4, 1\}$	$x * (y * z) = (x * y) * z.$ $x * 1 = x. 1 * x = x.$	$((a * a) * a) * a = 1.$
$\langle a, e   ae = 0, ea = a, e^2 = e \rangle$ $\cup \{1\} = \{0, a, e, 1\}$	$x * (y * z) = (x * y) * z.$ $x * 0 = 0. 0 * x = 0.$ $x * 1 = x. 1 * x = x.$	$a * e = 0.$ $e * a = a.$ $e * e = e.$

The tool will try to close the multiplication table, but if more than 20 elements are reached, an error will be returned.

Entering a semigroup as a presentation (or using given identities to find or filter varieties) demands the use of an automated theorem prover (in this site Prover9/Mace4), something usually very expensive (in time). Therefore a strategy to limit calls and also to speed-up the use of Prover9/Mace4 was implemented; see Table 11.

### 5.4 Finding an identity basis for a finitely generated variety

Let  $\mathbf{V}$  be any finitely generated variety. Then the number of maximal subvarieties of  $\mathbf{V}$  is some positive integer  $k \geq 1$ ; see Lee *et al.* [45, Proposition 4.1]. Let  $\mathbf{M}_1, \mathbf{M}_2, \dots, \mathbf{M}_k$  be these maximal subvarieties. By maximality, each  $\mathbf{M}_i$  can be defined within  $\mathbf{V}$  by some identity  $\mu_i$ . If  $k \geq 2$ , then  $\mathbf{V} = \mathbf{M}_i \vee \mathbf{M}_j$  for all distinct  $i$  and  $j$ ; otherwise,  $\mathbf{V}$  has a unique maximal subvariety and is said to be *prime*. It follows that each finitely generated variety is either prime or a join of some of its prime subvarieties.

#	Step	Description
1	Presentation	User enters a presentation in Prover9/Mace4 format (both the theory and relations).
2	Normalization	User formulas are normalized to a internal notation and ordering rules, to increase cache's hit rate.
3	Presentation cache (SQL)	If a similar presentation (in normalized notation) is recorded in SQL, its result will be used.
4	Proofs cache (user session)	If the user had requested other similar proofs during the session, the results are used to reduce the number of proofs.
5	Proofs cache (SQL)	If all users had requested other similar proofs recorded in SQL, theirs result will be used to speed the process.
6	Launch Prover9/Mace4	Launched at the same time, but the first to find a proof or counterexample (respectively) stops the other.

Table 11: Presentations caching algorithm

Now it is clear that for any finite semigroup  $S$ , the equality  $\text{var}\{S\} = \mathbf{V}$  holds if and only if  $S \in \mathbf{V}$  and  $S \notin \mathbf{M}_i$  for all  $i$ . However, if the variety  $\mathbf{V}$  is finitely based and a finite identity basis  $\Sigma$  is available, then the equality  $\text{var}\{S\} = \mathbf{V}$  holds whenever  $S \models \Sigma$  and  $S \not\models \mu_i$  for all  $i$ . Therefore the identity system  $(\Sigma; \mu_1, \mu_2, \dots, \mu_k)$ , called a *Bas-Max system* for  $\mathbf{V}$ , provides an easily verifiable sufficient condition to check if a finite semigroup generates  $\mathbf{V}$ . Presently, the website database contains Bas-Max systems for all of the following varieties:

- (a) varieties with a primitive generator of order up to 4;
- (b) proper subvarieties of Cross varieties in (a);
- (c) varieties with a primitive generator of order 5.

Now when a semigroup  $S$  entered into the website is shown to generate a variety  $\mathbf{V}$  via its Bas-Max system  $(\Sigma; \mu_1, \mu_2, \dots, \mu_k)$ , then besides the identity basis  $\Sigma$  for  $\text{var}\{S\}$ , other important information, such as the primitive generator for  $\mathbf{V}$ , any decomposition of  $\mathbf{V}$  into a join of its prime subvarieties, and the number of subvarieties of  $\mathbf{V}$ , will also be displayed by the website.

Bas-Max systems for varieties in (a) and (b), together with the aforementioned properties, will be listed in Section 6, while their proofs will be given

in the appendix sections. Justification of the Bas-Max systems for varieties in (c) will be disseminated elsewhere.

The website will be regularly updated with newly established Bas-Max systems for varieties.

Regarding groups up to order 255, the website displays the known information. See Figure 16.

**GAP Smallgroup:**

Order:	254	Sequence:	1
--------	-----	-----------	---

<b>The group you entered</b>	GAP Id: (254, 1) <input type="button" value="Gap"/> <input type="button" value="Cooked"/>
<b>Group Structure</b>	<i>D</i> 254 (dihedral)
<b>Group Variety</b>	Metabelian $A_2 A_{127}$ /Dihedral $D_{254}$
<b>Identity Basis</b>	(1) $x^{254} \approx 1$ (2) $[x, y]^2 \approx 1$ (3) $[x^{127}, y^{127}] \approx 1$ (4) $[x^{127}, [y, z]] \approx 1$ (5) $[[x, y], [z, w]] \approx 1$
<b>Specific Identities</b>	None
<b>Reference</b>	H. Neumann, Varieties of Groups, Springer, New York, 1967.

Figure 16: Companion website: information displayed for GAP smallgroup (254,1)

## 5.5 Testing for equivalent identity bases

Suppose we have a finite set  $\Sigma$  of identities and would like to know information about the variety  $[\Sigma]$  of semigroups, such as the primitive generator for  $[\Sigma]$  and the varieties covered by  $[\Sigma]$ . If the variety  $[\Sigma]$  happens to be in our database, then many of these information is available. The question is how do we identify  $[\Sigma]$  with a variety in the database. A tool was developed that will, by specifying one or more identities in Prover9 format, retrieve the variety whose identity basis is equivalent to  $\Sigma$ .

**Set of identities:**

Identities (or choose example below) ▾

y = y \* z.  
x = x \* x.

Go!

<b>Variety</b>	V(2, 3)
<b>Identity basis</b>	$ax \approx a$ <span style="border: 1px solid gray; padding: 2px;">Prover9</span>
<b>Primitive generator</b>	[11, 22]
<b>Common generator</b>	$LZ_2 = \langle a, b \mid a^2 = ab = a, b^2 = ba = b \rangle = \{a, b\}$

Figure 17: Companion website: example of testing for equivalent identity basis

## 5.6 Filtering varieties using conditions

Suppose we have some property and want to check which varieties in the database satisfy it. This can be done on the website, using these two distinct functionalities:

- (a) Returns the varieties whose identity basis is implied by the user's assumptions.
- (b) Returns the varieties whose identity basis implies the user's goals (see example in Figure 18 on page 56).

An automatic theorem prover and a finite model builder, which looks for counterexamples, will run simultaneously to check the implications, according to the user's choice, as in the following table.

Varieties whose identity basis is implied by the user's assumptions		Varieties whose identity basis implies the user's goals	
$assumptions \Rightarrow (identity\ basis \ \& \ goals)$		$(assumptions \ \& \ identity\ basis) \Rightarrow goals$	
Prover <i>Searches for proofs</i>	Finite Model Builder <i>Searches for models</i>	Prover <i>Searches for proofs</i>	Finite Model Builder <i>Searches for models</i>

Table 12: Companion website: user options for filtering varieties

**Assumptions:**

Enter assumptions using Prover9 syntax, for instance:  $x^*y=y^*x$ .

Varieties whose identity basis is implied by the user's assumptions:

Prover9

Mace4

**Goals:**

$x^*(y^*y) = x^*y$   
 $x^*y = y^*x$ .

Varieties whose identity basis implies the user's goals:

Prover9

Mace4

**Results:**

Proofs **4**

Countermodels **225**

Variety	Primitive Generator	Identity Basis	Common Generator	# max. subvar.									
V(1,1)	<table border="1" style="display: inline-table; border-collapse: collapse;"><tr><td>1</td></tr></table>	1	$x \approx y$	none	None								
1													
V(2,1)	<table border="1" style="display: inline-table; border-collapse: collapse;"><tr><td>1</td><td>1</td></tr><tr><td>1</td><td>1</td></tr></table>	1	1	1	1	$x^2 \approx xy$ $xy \approx yx$	$N_2 = \langle a \mid a^2 = 0 \rangle = \{0, a\}$	1					
1	1												
1	1												
V(2,2)	<table border="1" style="display: inline-table; border-collapse: collapse;"><tr><td>1</td><td>1</td></tr><tr><td>1</td><td style="background-color: #d4edda;">2</td></tr></table>	1	1	1	2	$x^2 \approx x$ $xy \approx yx$	$Sl_2 = \{0, 1\}$	1					
1	1												
1	2												
V(3,2)	<table border="1" style="display: inline-table; border-collapse: collapse;"><tr><td>1</td><td>1</td><td>1</td></tr><tr><td>1</td><td>1</td><td>1</td></tr><tr><td>1</td><td>1</td><td style="background-color: #d4edda;">3</td></tr></table>	1	1	1	1	1	1	1	1	3	$x^2a \approx xa$ $xy \approx yx$	none	2
1	1	1											
1	1	1											
1	1	3											

Figure 18: Companion website: example of filtering varieties - obtaining all varieties in database whose identity basis implies goals  $xy^2 = xy \wedge xy = yx$

## 5.7 Obtaining lattices of varieties

A tool was developed to obtain a lattice of a set of varieties created with the filtering tool. See Figure 19.

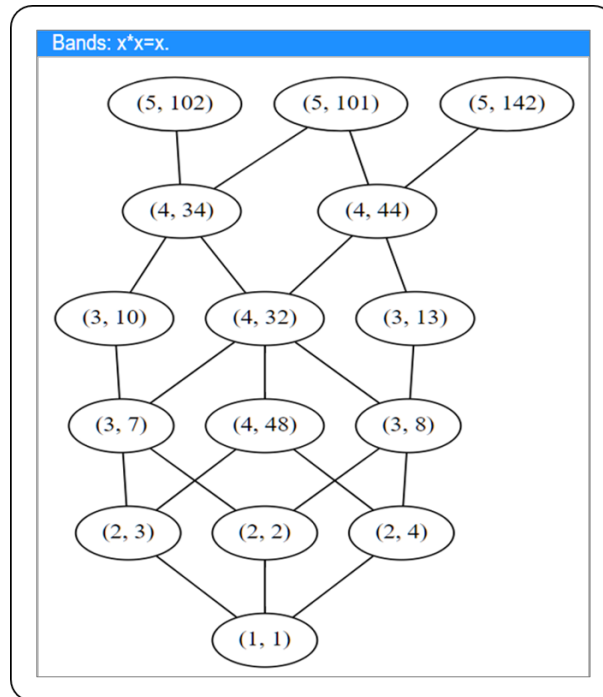

Figure 19: Companion website: obtaining the lattice of varieties generated by bands up to order 5

## 5.8 Extending the database: finding identity bases for new varieties

Suppose we have identity bases for all varieties generated by a semigroup of order  $n - 1$  and we want to find an identity basis for the variety generated some semigroup  $S$  of order  $n$ . If  $S$  does not belong to any variety generated by a semigroup of order less than  $n$ , then  $\text{var}\{S\}$  is a new variety and we want to find an identity basis for it. The website has a tool to try to find candidates of identities that can form an identity basis for  $\text{var}\{S\}$ . The first thing it does is to check, based on results from Subsection 4.3, if  $S$  is inherently non-finitely based. If the semigroup  $S$  is not inherently non-finitely based, then the website searches, in some *ad hoc* intelligent ways, for candidates of identities of  $S$  to form an identity basis for  $\text{var}\{S\}$ . Of course, if  $S$  happens to be non-finitely based, then the process will not terminate. But if we are lucky, then the website will produce a natural conjecture for an identity basis  $\Sigma$  for  $\text{var}\{S\}$ . The variety defined by  $\Sigma$  coincides with  $\text{var}\{S\}$  if the conjecture is correct, and properly contains  $\text{var}\{S\}$  otherwise. We checked this procedure against all varieties generated by semigroups of order

up to 5 and in every case, the procedure gave an identity basis equivalent to the known one.

Two algebras generate the same variety if and only they satisfy the same identities. Since checking whether or not a finite semigroup satisfies or violates some identities is a task achievable by a computer, a methodology was developed to:

- (a) Given a set of semigroups whose varieties do not coincide with the known varieties present in the database, we organize these semigroups into distinct subsets of semigroups that satisfy the same identities. Each subset now represents a potential new variety;
- (b) Given a semigroup, we search for identities it satisfies.

To obtain these goals we implemented two algorithms, (A) and (B). Algorithm (A) attains goals a) and b); algorithm (B) attains goal b). Both algorithms share the routine on page 59. The difference is that algorithm (A) runs this routine in parallel for all semigroups conjectured to generate the same variety while algorithm (B) tackles them individually. In practice, they might propose distinct bases of identities, although at the expense of a significantly greater computational time for algorithm (B). In the last part of both algorithms, several techniques are used to reduce the number of candidate identities.

## 6 Varieties generated by small semigroups

As mentioned in Subsection 5.4, the present section lists Bas-Max systems for all varieties generated by a semigroup of order up to 4 and for some that are their proper subvarieties. Important information such as primitive generators, decompositions into joins of prime subvarieties, and number of subvarieties are also given. To this end, the semigroups in Tables 13–15 play a crucial role; these semigroups are primitive generators for the varieties they generate, which are in fact precisely all prime varieties generated by a semigroup of order up to 4.

Some well-known semigroups in Tables 13–15 are the semilattice  $S\ell_2$  of order 2, the left zero band  $LZ_2$  of order 2, the right zero band  $RZ_2$  of order 2, the monogenic nilpotent semigroup

$$N_n = \langle a \mid a^n = 0 \rangle = \{a, a^2, \dots, a^{n-1}, 0\}$$

---

**Algorithm 2** Algorithms (A)/(B) - Identities testing routine

---

```

1: procedure FINDBASISN( $S, \text{maxWordSize}, \text{maxVars}$ )
2:    $\text{distinctResults} \leftarrow \{\}$ 
3:    $\text{resultsSequence} \leftarrow \{\}$ 
4:   for  $\text{wordSize} \leftarrow 1, \text{maxWordSize}$  do ▷ Loop word sizes
5:      $\text{numVar} \leftarrow \text{maxVars}(\text{wordSize})$ 
6:     ▷ Loop all words by using the Cartesian Product
7:     for all  $\text{word} \in X_{i=1}^{\text{wordSize}}[x_0, \dots, x_{\text{numVar}}]$  do
8:       for all  $s \in S$  do ▷ Loop all semigroups of input set
9:          $\text{result} \leftarrow \emptyset$ 
10:        ▷ Loop all variable values
11:        for all  $\text{variables} \in X_{i=1}^{\text{wordSize}}[0, \dots, \text{numVar}]$  do
12:           $\text{result} \leftarrow \text{result} + s[\text{word}, \text{variables}]$ 
13:        end for
14:        ▷ If necessary to properly compare expression solutions,
         $\text{result}$  is extended to maximum size
15:        if  $\text{numVar} < \text{numVarMax}$  then
16:           $\text{multiplier} = \text{Order}(s)^{\text{numVarMax} - \text{numVar}}$ 
17:          for  $i \leftarrow \text{Size}(\text{results}), -1, -1$  do
18:            for  $j \leftarrow 0, \text{multiplier}$  do
19:               $\text{result}(i * \text{multiplier} + j) \leftarrow \text{result}(i)$ 
20:            end for
21:          end for
22:        end if
23:
24:        if  $\text{result} \notin \text{distinctResults}$  then
25:          Insert  $\text{ZIP}(\text{result})$  into hash  $\text{distinctResults}$ 
26:        end if
27:        if  $\text{distinctResults.index} \notin \text{resultsSequence}(s)$  then
28:          Insert  $\text{distinctResults.index}$  into hash
         $\text{resultsSequence}(s)$ 
29:        end if
30:      end for
31:    end for
32:  end for
33:  return  $\text{distinctResults}, \text{resultsSequence}$ 
34: end procedure

```

---

$N_2$	1	2	$Sl_2$	1	2	$LZ_2$	1	2	$RZ_2$	1	2	$\mathbb{Z}_2$	1	2
1	1	1	1	1	1	1	1	1	1	1	2	1	1	2
2	1	1	2	1	2	2	2	2	2	1	2	2	2	1

Table 13: Primitive generators of prime varieties generated by a semigroups of order 2

$N_3$	1	2	3	$J$	1	2	3	$\overleftarrow{J}$	1	2	3	$N_2^1$	1	2	3
1	1	1	1	1	1	1	1	1	1	1	1	1	1	1	1
2	1	1	1	2	1	1	1	2	1	1	2	2	1	1	2
3	1	1	2	3	1	2	3	3	1	1	3	3	1	2	3

$LZ_2^1$	1	2	3	$RZ_2^1$	1	2	3	$\mathbb{Z}_3$	1	2	3
1	1	1	1	1	1	1	3	1	1	2	3
2	1	2	3	2	1	2	3	2	2	3	1
3	3	3	3	3	1	3	3	3	3	1	2

Table 14: Primitive generators of all prime varieties generated by a semigroups of order 3

of order  $n$ , and the cyclic group

$$\mathbb{Z}_n = \langle a \mid a^n = 1 \rangle = \{a, a^2, \dots, a^{n-1}, 1\}$$

of order  $n$ . Recall that for any semigroup  $S$ , the smallest monoid containing  $S$  is denoted by  $S^1$ , and the dual of  $S$  is denoted by  $\overleftarrow{S}$ .

In the remainder of the section, information on 88 varieties are grouped by the order of their primitive generators and given below in four subsections; these varieties are named Variety  $\mathbb{N}$ , or simply  $\mathbf{V}_{\mathbb{N}}$ , where  $\mathbb{N} \in \{1, 2, \dots, 88\}$ . Proofs and references for all results are deferred to the appendix sections.

To illustrate how information on each variety can be read, consider Variety 43 in Subsection 6.3, repeated here for reader convenience.

**Variety 43** (Subsection C.3).

(Gen) [1111, 1112, 3333, 1214]

(Bas)  $x^3 \approx x^2, axy \approx ayx$

(Max)  $x^2y^2 \approx y^2x^2; a^2x^2 \approx a^2x$

(Dec)  $\text{var}\{LZ_2\} \vee \text{var}\{N_2^1\}$

(Sub) Countably infinite

$F_4$	1 2 3 4	$G_4$	1 2 3 4	$N_4$	1 2 3 4
1	1 1 1 1	1	1 1 1 1	1	1 1 1 1
2	1 1 1 1	2	1 1 1 1	2	1 1 1 1
3	1 1 1 1	3	1 1 1 2	3	1 1 1 2
4	1 1 2 1	4	1 1 2 1	4	1 1 2 3
$N_3^1$	1 2 3 4	$B_0$	1 2 3 4	$A_0$	1 2 3 4
1	1 1 1 1	1	1 1 1 1	1	1 1 1 1
2	1 1 1 2	2	1 1 1 2	2	1 1 1 2
3	1 1 2 3	3	1 2 3 1	3	1 2 3 2
4	1 2 3 4	4	1 1 1 4	4	1 1 1 4
$J^1$	1 2 3 4	$P_2$	1 2 3 4	$\overleftarrow{J}^1$	1 2 3 4
1	1 1 1 1	1	1 1 1 1	1	1 1 1 1
2	1 1 1 2	2	1 1 1 3	2	1 1 2 2
3	1 2 3 3	3	3 3 3 3	3	1 1 3 3
4	1 2 3 4	4	4 4 4 4	4	1 2 3 4
$O_2$	1 2 3 4	$\overleftarrow{O}_2$	1 2 3 4	$\overleftarrow{P}_2$	1 2 3 4
1	1 1 1 1	1	1 1 3 3	1	1 1 3 4
2	1 2 3 4	2	1 2 3 4	2	1 1 3 4
3	3 3 3 3	3	1 3 3 1	3	1 1 3 4
4	3 4 1 2	4	1 4 3 2	4	1 3 3 4
				$\mathbb{Z}_4$	1 2 3 4
					1 2 3 4
					2 1 4 3
					3 4 2 1
					4 3 1 2

Table 15: Primitive generators of all prime varieties generated by a semi-groups of order 4

The vector of the primitive generator of the variety  $\mathbf{V}_{43}$  is given in (Gen). The two identities in (Bas) form an identity basis for  $\mathbf{V}_{43}$ , while each identity in (Max) defines within  $\mathbf{V}_{43}$  a maximal subvariety; in other words, the identities in (Bas) and (Max) form a Bas-Max system for  $\mathbf{V}_{43}$ . The join in (Dec) is a decomposition of  $\mathbf{V}_{43}$  into the join of the prime subvarieties  $\text{var}\{LZ_2\}$  and  $\text{var}\{N_2^1\}$ . As indicated in (Sub), the variety  $\mathbf{V}_{43}$  has countably infinitely many subvarieties. All these results regarding  $\mathbf{V}_{43}$  are established in Subsection C.3.

For another example, consider Variety 78 in Subsection 6.4.

**Variety 78** (Zhang and Luo [94, Variety C in Figure 4]; Figure 23).

(Gen) [11111, 11113, 11133, 11144, 11155]

(Bas)  $ax^2 \approx ax$ ,  $xyx \approx x^2y$ ,  $a^2xy \approx a^2yx$

(Max)  $axy \approx ayx$

(Dec) None

(Sub) 11

The vector of the primitive generator of the variety  $\mathbf{V}_{78}$  is given in (Gen). The three identities in (Bas) form an identity basis for  $\mathbf{V}_{78}$ , while the identity in (Max) define the unique maximal subvariety within  $\mathbf{V}_{78}$ . Since  $\mathbf{V}_{78}$  has only one maximal subvariety, it is prime and cannot be decomposed into a join of two or more prime subvarieties, as indicated by “None” in (Dec). The number 11 in (Sub) is the number of subvarieties of  $\mathbf{V}_{78}$ . Justification of the all these results regarding  $\mathbf{V}_{78}$  can be found in Zhang and Luo [94, Variety C in Figure 4]. For any variety with finitely many subvarieties, its lattice of subvarieties is given in Section B. Specifically, the lattice of subvarieties of  $\mathbf{V}_{78}$  can be found in Figure 23.

## 6.1 Varieties with primitive generator of order 2

**Variety 1** (Evans [13, Figure 3]).

(Gen) [11, 11] =  $N_2$

(Bas)  $x^2 \approx xy$ ,  $xy \approx yx$

(Max)  $x \approx y$

(Dec) None

(Sub) 2

**Variety 2** (Evans [13, Figure 3]).

(Gen) [11, 12] =  $S\ell_2$

(Bas)  $x^2 \approx x$ ,  $xy \approx yx$

(Max)  $x \approx y$

(Dec) None

(Sub) 2

**Variety 3** (Evans [13, Figure 3]).

(Gen)  $[11, 22] = LZ_2$

(Bas)  $ax \approx a$

(Max)  $x \approx y$

(Dec) None

(Sub) 2

**Variety 4** (Evans [13, Figure 3]).

(Gen)  $[12, 12] = RZ_2$

(Bas)  $xa \approx a$

(Max)  $x \approx y$

(Dec) None

(Sub) 2

**Variety 5** (Lee *et al.* [45, Proposition 5.4]).

(Gen)  $[12, 21] = \mathbb{Z}_2$

(Bas)  $x^2a \approx a, xy \approx yx$

(Max)  $x \approx y$

(Dec) None

(Sub) 2

## 6.2 Varieties with primitive generator of order 3

**Variety 6** (Tishchenko [79, Variety  $\mathbf{CN}_3$  on page 439]; Figures 25, 26, 27, or 30).

$$\text{(Gen)} \quad [111, 111, 112] = N_3$$

$$\text{(Bas)} \quad x^3 \approx xyz, \quad xy \approx yx$$

$$\text{(Max)} \quad x^3 \approx x^2$$

$$\text{(Dec)} \quad \text{None}$$

$$\text{(Sub)} \quad 4$$

**Variety 7** (Evans [13, Figure 3]; Figures 20, 22, 23, 26, or 28).

$$\text{(Gen)} \quad [111, 111, 113]$$

$$\text{(Bas)} \quad x^2a \approx xa, \quad xy \approx yx$$

$$\text{(Max)} \quad x^2 \approx x; \quad x^2 \approx xy$$

$$\text{(Dec)} \quad \text{var}\{N_2\} \vee \text{var}\{S\ell_2\}$$

$$\text{(Sub)} \quad 4$$

**Variety 8** (Zhang and Luo [94, Variety  $\mathbf{D}$  in Figure 2]; Figures 20, 22, 23, or 28).

$$\text{(Gen)} \quad [111, 111, 123] = J$$

$$\text{(Bas)} \quad x^2a \approx xa, \quad xy^2 \approx yx^2$$

$$\text{(Max)} \quad xy \approx yx$$

$$\text{(Dec)} \quad \text{None}$$

$$\text{(Sub)} \quad 5$$

**Variety 9** (Evans [13, Figure 3]; Figures 22, 23, or 25).

$$\text{(Gen)} \quad [111, 111, 333]$$

$$\text{(Bas)} \quad x^2 \approx xy$$

$$\text{(Max)} \quad x^2 \approx x; \quad xy \approx yx$$

$$\text{(Dec)} \quad \text{var}\{N_2\} \vee \text{var}\{LZ_2\}$$

(Sub) 4

**Variety 10** (Zhang and Luo [94, Variety **E** in Figure 2]; Figures 20, 22, 23, or 28).

(Gen)  $[111, 112, 113] = \overleftarrow{J}$

(Bas)  $ax^2 \approx ax, x^2y \approx y^2x$

(Max)  $xy \approx yx$

(Dec) None

(Sub) 5

**Variety 11** (Subsection C.1).

(Gen)  $[111, 112, 123] = N_2^1$

(Bas)  $x^3 \approx x^2, xy \approx yx$

(Max)  $x^2y \approx xy^2$

(Dec) None

(Sub) Countably infinite

**Variety 12** (Gerhard and Petrich [16, Variety LNB in Section 2]; Figures 21, 22, 23, or 24).

(Gen)  $[111, 121, 333]$

(Bas)  $x^2 \approx x, axy \approx ayx$

(Max)  $xy \approx x; xy \approx yx$

(Dec)  $\text{var}\{S\ell_2\} \vee \text{var}\{LZ_2\}$

(Sub) 4

**Variety 13** (Gerhard and Petrich [16, Variety RNB in Section 2]; Figures 21, 22, 23, or 24).

(Gen)  $[111, 123, 123]$

(Bas)  $x^2 \approx x, xya \approx yxa$

(Max)  $xy \approx y; xy \approx yx$

(Dec)  $\text{var}\{S\ell_2\} \vee \text{var}\{RZ_2\}$

(Sub) 4

**Variety 14** (Subsection B.9).

(Gen) [111, 123, 132]

(Bas)  $x^3 \approx x, xy \approx yx$

(Max)  $x^2 \approx x; x^2y \approx y$

(Dec)  $\text{var}\{S\ell_2\} \vee \text{var}\{\mathbb{Z}_2\}$

(Sub) 4

**Variety 15** (Gerhard and Petrich [16, Variety LRB in Section 2]; Figures 21, 22, 23, or 24).

(Gen) [111, 123, 333] =  $LZ_2^1$

(Bas)  $x^2 \approx x, xyx \approx xy$

(Max)  $axy \approx ayx$

(Dec) None

(Sub) 5

**Variety 16** (Evans [13, Figure 3]; Figures 22, 23, or 25).

(Gen) [113, 113, 113]

(Bas)  $x^2 \approx yx$

(Max)  $x^2 \approx x; xy \approx yx$

(Dec)  $\text{var}\{N_2\} \vee \text{var}\{RZ_2\}$

(Sub) 4

**Variety 17** (Subsection B.9).

(Gen) [113, 113, 331]

(Bas)  $x^2ab \approx ab, xy \approx yx$

(Max)  $x^3 \approx x; x^3 \approx x^2$

(Dec)  $\text{var}\{N_2\} \vee \text{var}\{\mathbb{Z}_2\}$

(Sub) 4

**Variety 18** (Gerhard and Petrich [16, Variety RRB in Section 2]; Figures 21, 22, 23, or 24).

(Gen)  $[113, 123, 133] = RZ_2^1$

(Bas)  $x^2 \approx x, xyx \approx yx$

(Max)  $xya \approx yxa$

(Dec) None

(Sub) 5

**Variety 19** (Lee *et al.* [45, Proposition 5.4]).

(Gen)  $[123, 231, 312] = \mathbb{Z}_3$

(Bas)  $x^3a \approx a, xy \approx yx$

(Max)  $x \approx y$

(Dec) None

(Sub) 2

### 6.3 Varieties with primitive generator of order 4

**Variety 20** (Tishchenko [79, Variety  $\mathbf{N}_{3,2}$  on page 439]; Figures 20 or 25).

(Gen)  $[1111, 1111, 1111, 1121] = F_4$

(Bas)  $x^2 \approx yzt$

(Max)  $xy \approx yx$

(Dec) None

(Sub) 4

**Variety 21** (Tishchenko [79, Variety  $\mathbf{N}_3$  on page 438]; Figure 25).

(Gen)  $[1111, 1111, 1111, 1122]$

(Bas)  $x^3 \approx yzt$

(Max)  $x^3 \approx x^2; xy \approx yx$

(Dec)  $\text{var}\{N_3\} \vee \text{var}\{F_4\}$

(Sub) 6

**Variety 22** (Tishchenko [79, Variety  $\mathbf{CN}_{3,2}$  on page 439] ; Figures 20, 25, 26, 27, or 30).

(Gen)  $[1111, 1111, 1112, 1121] = G_4$

(Bas)  $x^2 \approx xyz, xy \approx yx$

(Max)  $x^2 \approx xy$

(Dec) None

(Sub) 3

**Variety 23** (Lee *et al.* [45, Condition A8]; Figure 30).

(Gen)  $[1111, 1111, 1112, 1123] = N_4$

(Bas)  $x^4 \approx xyzt, x^2y \approx xy^2, xy \approx yx$

(Max)  $x^4 \approx x^3$

(Dec) None

(Sub) 8

**Variety 24** (Zhang and Luo [94, Variety  $\mathbf{D} \vee \mathbf{E}$  in Figure 2]; Figure 20).

(Gen)  $[1111, 1111, 1113, 1214]$

(Bas)  $x^3 \approx x^2, xyx \approx x^2y^2, xyx \approx y^2x^2, ax^2b \approx axb$

(Max)  $xyx \approx x^2y; xyx \approx yx^2$

(Dec)  $\text{var}\{J\} \vee \text{var}\{\overleftarrow{J}\}$

(Sub) 13

**Variety 25** (Subsection C.2).

(Gen)  $[1111, 1111, 1113, 1234]$

(Bas)  $x^3 \approx x^2, x^2y^2 \approx y^2x^2, xya \approx yxa$

(Max)  $x^2y \approx yx^2; xy^2 \approx yx^2$

(Dec)  $\text{var}\{J\} \vee \text{var}\{N_2^1\}$

(Sub) Countably infinite

**Variety 26** (Lee *et al.* [45, Proposition 6.14]; Figure 26).

(Gen) [1111, 1111, 1121, 1114]

(Bas)  $x^2ab \approx xab, xy \approx yx$

(Max)  $x^3 \approx x^2; x^3 \approx y^3$

(Dec)  $\text{var}\{S\ell_2\} \vee \text{var}\{N_3\}$

(Sub) 8

**Variety 27** (Tishchenko [79, Variety  $\mathbf{L}_{1,3}$  on page 438]; Figure 25).

(Gen) [1111, 1111, 1121, 4444]

(Bas)  $x^3 \approx xyz$

(Max)  $x^3 \approx x^2; x^3 \approx y^3$

(Dec)  $\text{var}\{LZ_2\} \vee \text{var}\{N_3\}$

(Sub) 10

**Variety 28** (Evans [13, Figure 3]; Figures 22 or 23).

(Gen) [1111, 1111, 1131, 4444]

(Bas)  $x^2a \approx xa, ax^2 \approx ax, axy \approx ayx$

(Max)  $x^2 \approx x; x^2 \approx xy; xy \approx yx$

(Dec)  $\text{var}\{N_2\} \vee \text{var}\{S\ell_2\} \vee \text{var}\{LZ_2\}$

(Sub) 8

**Variety 29** (Evans [13, Figure 3]; Figures 22 or 23).

(Gen) [1111, 1111, 1134, 1134]

(Bas)  $x^2a \approx xa, ax^2 \approx ax, xya \approx yxa$

(Max)  $x^2 \approx x; x^2 \approx yx; xy \approx yx$

$$\text{(Dec)} \quad \text{var}\{N_2\} \vee \text{var}\{S\ell_2\} \vee \text{var}\{RZ_2\}$$

$$\text{(Sub)} \quad 8$$

**Variety 30** (Subsection B.9).

$$\text{(Gen)} \quad [1111, 1111, 1134, 1143]$$

$$\text{(Bas)} \quad x^3a \approx xa, xy \approx yx$$

$$\text{(Max)} \quad x^3 \approx x; x^3 \approx x^2; x^2 \approx y^2$$

$$\text{(Dec)} \quad \text{var}\{N_2\} \vee \text{var}\{S\ell_2\} \vee \text{var}\{Z_2\}$$

$$\text{(Sub)} \quad 8$$

**Variety 31** (Zhang and Luo [94, Variety  $\mathbf{L}^1 \vee \mathbf{N}$  in Figure 5]; Figures 22 or 23).

$$\text{(Gen)} \quad [1111, 1111, 1134, 4444]$$

$$\text{(Bas)} \quad x^2a \approx xa, ax^2 \approx ax, xyx \approx xy$$

$$\text{(Max)} \quad x^2 \approx x; axy \approx ayx$$

$$\text{(Dec)} \quad \text{var}\{N_2\} \vee \text{var}\{LZ_2^1\}$$

$$\text{(Sub)} \quad 10$$

**Variety 32** (Zhang and Luo [94, Variety  $\mathbf{D} \vee \mathbf{L}$  in Figure 4]; Figure 22).

$$\text{(Gen)} \quad [1111, 1111, 1231, 4444]$$

$$\text{(Bas)} \quad x^2a \approx xa, axy^2 \approx ayx^2$$

$$\text{(Max)} \quad ax^2 \approx ax; xy^2 \approx yx^2$$

$$\text{(Dec)} \quad \text{var}\{LZ_2\} \vee \text{var}\{J\}$$

$$\text{(Sub)} \quad 10$$

**Variety 33** (Dual of Variety 41; Figure 23).

$$\text{(Gen)} \quad [1111, 1111, 1234, 1234]$$

$$\text{(Bas)} \quad x^2a \approx xa, xya \approx yxa$$

$$\text{(Max)} \quad ax^2 \approx ax; xy^2 \approx yx^2$$

(Dec)  $\text{var}\{RZ_2\} \vee \text{var}\{J\}$

(Sub) 10

**Variety 34** (Subsection B.9).

(Gen) [1111, 1111, 1234, 1243]

(Bas)  $x^3a \approx xa, x^2y^2 \approx y^2x^2, xya \approx yxa$

(Max)  $x^3 \approx x^2; xy \approx yx$

(Dec)  $\text{var}\{\mathbb{Z}_2\} \vee \text{var}\{J\}$

(Sub) 10

**Variety 35** (Edmunds [11, Semigroup  $S(4, 11)$  on page 70]; Figure 22).

(Gen) [1111, 1111, 1234, 4444]

(Bas)  $x^2a \approx xa, xyx \approx xy^2$

(Max)  $ax^2 \approx ax; axy^2 \approx ayx^2$

(Dec)  $\text{var}\{J\} \vee \text{var}\{LZ_2^1\}$

(Sub) 13

**Variety 36** (Subsection C.2).

(Gen) [1111, 1112, 1113, 1134]

(Bas)  $x^3 \approx x^2, x^2y^2 \approx y^2x^2, axy \approx ayx$

(Max)  $x^2y \approx yx^2; x^2y \approx y^2x$

(Dec)  $\text{var}\{\overleftarrow{J}\} \vee \text{var}\{N_2^1\}$

(Sub) Countably infinite

**Variety 37** (Subsection C.1).

(Gen) [1111, 1112, 1123, 1234] =  $N_3^1$

(Bas)  $x^4 \approx x^3, xy \approx yx$

(Max)  $x^3y^2 \approx x^2y^3$

(Dec) None

(Sub) Countably infinite

**Variety 38** (Subsection C.5).

(Gen)  $[1111, 1112, 1231, 1114] = B_0$

(Bas)  $x^3 \approx x^2, x^2yx^2 \approx yxy, x^2y^2 \approx y^2x^2$

(Max)  $a^2x^2b^2 \approx a^2xb^2$

(Dec) None

(Sub) Countably infinite

**Variety 39** (Subsection C.5).

(Gen)  $[1111, 1112, 1232, 1114] = A_0$

(Bas)  $x^3 \approx x^2, x^2yx^2 \approx yxy$

(Max)  $x^2y^2 \approx y^2x^2$

(Dec) None

(Sub) Countably infinite

**Variety 40** (Subsection C.6).

(Gen)  $[1111, 1112, 1233, 1234] = J^1$

(Bas)  $x^3 \approx x^2, x^2y^2 \approx y^2x^2, xyx \approx yx^2$

(Max)  $x^2ya^2 \approx yx^2a^2$

(Dec) None

(Sub) Countably infinite

**Variety 41** (Zhang and Luo [94, Variety  $\mathbf{E} \vee \mathbf{L}$  in Figure 4]; Figure 23).

(Gen)  $[1111, 1112, 3333, 1114]$

(Bas)  $ax^2 \approx ax, axy \approx ayx$

(Max)  $x^2a \approx xa; x^2y \approx y^2x$

(Dec)  $\text{var}\{LZ_2\} \vee \text{var}\{\overleftarrow{J}\}$

(Sub) 10

**Variety 42** (Edmunds [11, Semigroup  $S(4, 25)$  on page 70]; Figure 23).

(Gen) [1111, 1112, 3333, 1134]

(Bas)  $ax^2 \approx ax$ ,  $xyx \approx x^2y$

(Max)  $x^2a \approx xa$ ;  $a^2xy \approx a^2yx$

(Dec)  $\text{var}\{\overleftarrow{J}\} \vee \text{var}\{LZ_2^1\}$

(Sub) 14

**Variety 43** (Subsection C.3).

(Gen) [1111, 1112, 3333, 1214]

(Bas)  $x^3 \approx x^2$ ,  $axy \approx ayx$

(Max)  $x^2y^2 \approx y^2x^2$ ;  $a^2x^2 \approx a^2x$

(Dec)  $\text{var}\{LZ_2\} \vee \text{var}\{N_2^1\}$

(Sub) Countably infinite

**Variety 44** (Subsection C.4).

(Gen) [1111, 1112, 3333, 1234]

(Bas)  $x^3 \approx x^2$ ,  $xyx \approx x^2y$

(Max)  $a^2x^2 \approx a^2x$ ;  $a^2x^2y^2 \approx a^2y^2x^2$

(Dec)  $\text{var}\{N_2^1\} \vee \text{var}\{LZ_2^1\}$

(Sub) Countably infinite

**Variety 45** (Tishchenko [79, Variety  $\mathbf{L}_{2,2}$  on page 438]; Figure 25).

(Gen) [1111, 1113, 3333, 4444] =  $P_2$

(Bas)  $abx \approx ab$

(Max)  $x^2 \approx xy$

(Dec) None

(Sub) 5

**Variety 46** (Dual of Variety 40).

- (Gen) [1111, 1122, 1133, 1234] =  $\overleftarrow{J^1}$   
 (Bas)  $x^3 \approx x^2$ ,  $x^2y^2 \approx y^2x^2$ ,  $xyx \approx x^2y$   
 (Max)  $a^2x^2y \approx a^2yx^2$   
 (Dec) None  
 (Sub) Countably infinite

**Variety 47** (Dual of Variety 32; Figure 22).

- (Gen) [1111, 1122, 1134, 1134]  
 (Bas)  $ax^2 \approx ax$ ,  $x^2ya \approx y^2xa$   
 (Max)  $x^2a \approx xa$ ;  $x^2y \approx y^2x$   
 (Dec)  $\text{var}\{RZ_2\} \vee \text{var}\{\overleftarrow{J}\}$   
 (Sub) 10

**Variety 48** (Dual of Variety 34).

- (Gen) [1111, 1122, 1134, 1143]  
 (Bas)  $ax^3 \approx ax$ ,  $x^2y^2 \approx y^2x^2$ ,  $axy \approx ayx$   
 (Max)  $x^3 \approx x^2$ ;  $xy \approx yx$   
 (Dec)  $\text{var}\{Z_2\} \vee \text{var}\{\overleftarrow{J}\}$   
 (Sub) 10

**Variety 49** (Subsection C.3).

- (Gen) [1111, 1122, 1234, 1234]  
 (Bas)  $x^3 \approx x^2$ ,  $xya \approx yxa$   
 (Max)  $x^2y^2 \approx y^2x^2$ ;  $x^2a^2 \approx xa^2$   
 (Dec)  $\text{var}\{RZ_2\} \vee \text{var}\{N_2^1\}$   
 (Sub) Countably infinite

**Variety 50** (Subsection C.1).

(Gen) [1111, 1122, 1234, 1243]

(Bas)  $x^4 \approx x^2$ ,  $xy \approx yx$

(Max)  $x^3 \approx x^2$ ;  $x^3y \approx xy^3$

(Dec)  $\text{var}\{\mathbb{Z}_2\} \vee \text{var}\{N_2^1\}$

(Sub) Countably infinite

**Variety 51** (Gerhard and Petrich [16, Variety NB in Section 2]; Figure 21).

(Gen) [1111, 1214, 3333, 1214]

(Bas)  $x^2 \approx x$ ,  $axya \approx ayxa$

(Max)  $xyx \approx x$ ;  $xyx \approx xy$ ;  $xyx \approx yx$

(Dec)  $\text{var}\{S\ell_2\} \vee \text{var}\{LZ_2\} \vee \text{var}\{RZ_2\}$

(Sub) 8

**Variety 52** (Petrich [60, Lemma 7.3(vii)]; Figure 24).

(Gen) [1111, 1214, 3333, 1412]

(Bas)  $x^3 \approx x$ ,  $axy \approx ayx$

(Max)  $x^2 \approx x$ ;  $xy \approx yx$ ;  $ax^2 \approx a$

(Dec)  $\text{var}\{S\ell_2\} \vee \text{var}\{LZ_2\} \vee \text{var}\{\mathbb{Z}_2\}$

(Sub) 8

**Variety 53** (Gerhard and Petrich [16, Variety LQNB in Section 2]; Figure 21).

(Gen) [1111, 1234, 1234, 4444]

(Bas)  $x^2 \approx x$ ,  $xyxa \approx xya$

(Max)  $xyx \approx xy$ ;  $axya \approx ayxa$

(Dec)  $\text{var}\{RZ_2\} \vee \text{var}\{LZ_2^1\}$

(Sub) 10

**Variety 54** (Tishchenko [78, Variety  $\mathbf{V}_2$  on page 111]; Figure 24).

(Gen) [1111, 1234, 1324, 4444]

(Bas)  $x^3 \approx x$ ,  $xyx \approx x^2y$

(Max)  $x^2 \approx x$ ;  $axy \approx ayx$

(Dec)  $\text{var}\{\mathbb{Z}_2\} \vee \text{var}\{LZ_2^1\}$

(Sub) 10

**Variety 55** (Subsection B.9).

(Gen) [1111, 1234, 1342, 1423]

(Bas)  $x^4 \approx x$ ,  $xy \approx yx$

(Max)  $x^2 \approx x$ ;  $x^3a \approx a$

(Dec)  $\text{var}\{Sl_2\} \vee \text{var}\{\mathbb{Z}_3\}$

(Sub) 4

**Variety 56** (Tishchenko [78, Proposition 2.25]; Figure 24).

(Gen) [1111, 1234, 3333, 3412] =  $O_2$

(Bas)  $x^3 \approx x$ ,  $xyxy \approx xy^2x$

(Max)  $xyx \approx x^2y$

(Dec) None

(Sub) 11

**Variety 57** (Dual of Variety 27; Figure 25).

(Gen) [1114, 1114, 1124, 1114]

(Bas)  $x^3 \approx yzx$

(Max)  $x^3 \approx x^2$ ;  $x^3 \approx y^3$

(Dec)  $\text{var}\{RZ_2\} \vee \text{var}\{N_3\}$

(Sub) 10

**Variety 58** (Subsection B.8).

(Gen) [1114, 1114, 1124, 4441]

(Bas)  $x^2abc \approx abc, xy \approx yx$

(Max)  $x^4 \approx x^2; x^4 \approx x^3$

(Dec)  $\text{var}\{\mathbb{Z}_2\} \vee \text{var}\{N_3\}$

(Sub) 8

**Variety 59** (Dual of Variety 31; Figures 22 or 23).

(Gen) [1114, 1114, 1134, 1144]

(Bas)  $x^2a \approx xa, ax^2 \approx ax, xyx \approx yx$

(Max)  $x^2 \approx x; xya \approx yxa$

(Dec)  $\text{var}\{N_2\} \vee \text{var}\{RZ_2^1\}$

(Sub) 10

**Variety 60** (Dual of Variety 42; Figure 23).

(Gen) [1114, 1114, 1234, 1144]

(Bas)  $x^2a \approx xa, xyx \approx yx^2$

(Max)  $ax^2 \approx ax; xya^2 \approx yxa^2$

(Dec)  $\text{var}\{J\} \vee \text{var}\{RZ_2^1\}$

(Sub) 14

**Variety 61** (Dual of Variety 35; Figure 22).

(Gen) [1114, 1124, 1134, 1144]

(Bas)  $ax^2 \approx ax, xyx \approx y^2x$

(Max)  $x^2a \approx xa; x^2ya \approx y^2xa$

(Dec)  $\text{var}\{\overleftarrow{J}\} \vee \text{var}\{RZ_2^1\}$

(Sub) 13

**Variety 62** (Subsection C.4).

(Gen) [1114, 1124, 1234, 1144]

(Bas)  $x^3 \approx x^2, xyx \approx yx^2$

$$\text{(Max)} \quad x^2a^2 \approx xa^2; \quad x^2y^2a^2 \approx y^2x^2a^2$$

$$\text{(Dec)} \quad \text{var}\{N_2^1\} \vee \text{var}\{RZ_2^1\}$$

(Sub) Countably infinite

**Variety 63** (Gerhard and Petrich [16, Variety RQNB in Section 2]; Figure 21).

$$\text{(Gen)} \quad [1114, 1224, 1334, 1444]$$

$$\text{(Bas)} \quad x^2 \approx x, \quad axyx \approx ayx$$

$$\text{(Max)} \quad xyx \approx yx; \quad axya \approx ayxa$$

$$\text{(Dec)} \quad \text{var}\{LZ_2\} \vee \text{var}\{RZ_2^1\}$$

(Sub) 10

**Variety 64** (Dual to Variety 52; Figure 24).

$$\text{(Gen)} \quad [1114, 1234, 1234, 4441]$$

$$\text{(Bas)} \quad x^3 \approx x, \quad xya \approx yxa$$

$$\text{(Max)} \quad x^2 \approx x; \quad x^2a \approx a; \quad xy \approx yx$$

$$\text{(Dec)} \quad \text{var}\{Sl_2\} \vee \text{var}\{RZ_2\} \vee \text{var}\{Z_2\}$$

(Sub) 8

**Variety 65** (Dual of Variety 54; Figure 24).

$$\text{(Gen)} \quad [1114, 1234, 1324, 1444]$$

$$\text{(Bas)} \quad x^3 \approx x, \quad xyx \approx yx^2$$

$$\text{(Max)} \quad x^2 \approx x; \quad xya \approx yxa$$

$$\text{(Dec)} \quad \text{var}\{Z_2\} \vee \text{var}\{RZ_2^1\}$$

(Sub) 10

**Variety 66** (Dual of Variety 56; Figure 24).

$$\text{(Gen)} \quad [1133, 1234, 1331, 1432] = \overleftarrow{O}_2$$

$$\text{(Bas)} \quad x^3 \approx x, \quad xyxy \approx yx^2y$$

(Max)  $xyx \approx yx^2$

(Dec) None

(Sub) 11

**Variety 67** (Gerhard and Petrich [16, Variety Rec B in Section 2]; Figure 21).

(Gen) [1133, 2244, 1133, 2244]

(Bas)  $xyx \approx x$

(Max)  $xy \approx x; xy \approx y$

(Dec)  $\text{var}\{LZ_2\} \vee \text{var}\{RZ_2\}$

(Sub) 4

**Variety 68** (Tishchenko [78, Variety  $\mathbf{A}_2 \vee \mathbf{L}_1$  on page 108]; Figure 24).

(Gen) [1133, 2244, 3311, 4422]

(Bas)  $ax^2 \approx a, axy \approx ayx$

(Max)  $x^2 \approx x; x^2 \approx y^2$

(Dec)  $\text{var}\{LZ_2\} \vee \text{var}\{Z_2\}$

(Sub) 4

**Variety 69** (Dual of Variety 45; Figure 25).

(Gen) [1134, 1134, 1134, 1334] =  $\overleftarrow{P}_2$

(Bas)  $xab \approx ab$

(Max)  $x^2 \approx yx$

(Dec) None

(Sub) 5

**Variety 70** (Subsection B.9).

(Gen) [1134, 1134, 3341, 4413]

(Bas)  $x^3ab \approx ab, xy \approx yx$

(Max)  $x^4 \approx x; x^3 \approx x^2$

(Dec)  $\text{var}\{N_2\} \vee \text{var}\{Z_3\}$

(Sub) 4

**Variety 71** (Dual of Variety 68; Figure 24).

(Gen) [1234, 1234, 3412, 3412]

(Bas)  $x^2a \approx a, xya \approx yxa$

(Max)  $x^2 \approx x; x^2 \approx y^2$

(Dec)  $\text{var}\{RZ_2\} \vee \text{var}\{Z_2\}$

(Sub) 4

**Variety 72** (Lee *et al.* [45, Proposition 5.4]; Figure 29).

(Gen) [1234, 2143, 3421, 4312] =  $Z_4$

(Bas)  $x^4a \approx a, xy \approx yx$

(Max)  $x^3 \approx x$

(Dec) None

(Sub) 3

## 6.4 Some varieties with primitive generator of order greater than 4

**Variety 73** (Zhang and Luo [94, Variety  $\mathbf{F} \vee \mathbf{S}$  in Figure 2]; Figure 20).

(Gen) [11111, 11111, 11111, 11141, 11211]

(Bas)  $x^3 \approx x^2, x^2ab \approx xab, xya \approx yxa, axy \approx ayx$

(Max)  $x^2y \approx x^2; xy \approx yx$

(Dec)  $\text{var}\{S\ell_2\} \vee \text{var}\{F_4\}$

(Sub) 8

**Variety 74** (Tishchenko [79, Variety  $\mathbf{V}_{1,3}$  on page 439]; Figure 25).

(Gen) [11111, 11111, 11111, 11211, 55555]

(Bas)  $x^2 \approx xyz$

(Max)  $x^2 \approx xy; x^2 \approx y^2$

(Dec)  $\text{var}\{LZ_2\} \vee \text{var}\{G_4\}$

(Sub) 7

**Variety 75** (Dual of Variety 78; Figure 23).

(Gen) [11111, 11111, 11111, 11345, 13345]

(Bas)  $x^2a \approx xa, xyx \approx yx^2, xya^2 \approx yxa^2$

(Max)  $xya \approx yxa$

(Dec) None

(Sub) 11

**Variety 76** (Zhang and Luo [94, Variety  $\mathbf{G} \vee \mathbf{S}$  in Figure 2]; Figures 20 or 26).

(Gen) [11111, 11111, 11112, 11141, 11211]

(Bas)  $x^3 \approx x^2, x^2ab \approx xab, xy \approx yx$

(Max)  $x^2a \approx xa; x^2 \approx y^2$

(Dec)  $\text{var}\{S\ell_2\} \vee \text{var}\{G_4\}$

(Sub) 6

**Variety 77** (Tishchenko [79, Variety  $\mathbf{L}_{2,3}$  in Proposition 3.1]; Figure 25).

(Gen) [11111, 11111, 11214, 44444, 55555]

(Bas)  $xyx \approx xyz$

(Max)  $x^3 \approx x^2; x^3 \approx xyx$

(Dec)  $\text{var}\{N_3\} \vee \text{var}\{P_2\}$

(Sub) 13

**Variety 78** (Zhang and Luo [94, Variety  $\mathbf{C}$  in Figure 4]; Figure 23).

(Gen) [11111, 11113, 11133, 11144, 11155]

(Bas)  $ax^2 \approx ax, xyx \approx x^2y, a^2xy \approx a^2yx$

(Max)  $axy \approx ayx$

(Dec) None

(Sub) 11

**Variety 79** (Gerhard and Petrich [16, Variety RB in Section 2]; Figure 21).

(Gen) [11111, 12125, 33333, 12345, 12155]

(Bas)  $x^2 \approx x, xyxzx \approx xyzx$

(Max)  $axyx \approx ayx; xyxa \approx xya$

(Dec)  $\text{var}\{LZ_2^1\} \vee \text{var}\{RZ_2^1\}$

(Sub) 13

**Variety 80** (Dual of Variety 74; Figure 25).

(Gen) [11115, 11115, 11115, 11215, 11115]

(Bas)  $x^2 \approx yzx$

(Max)  $x^2 \approx yx; x^2 \approx y^2$

(Dec)  $\text{var}\{RZ_2\} \vee \text{var}\{G_4\}$

(Sub) 7

**Variety 81** (Dual of Variety 77; Figure 25).

(Gen) [11145, 11145, 11245, 11145, 11445]

(Bas)  $xyx \approx zyx$

(Max)  $x^3 \approx x^2; x^3 \approx xyx$

(Dec)  $\text{var}\{N_3\} \vee \text{var}\{\overleftarrow{P}_2\}$

(Sub) 13

**Variety 82** (Zhang and Luo [94, Variety  $\mathbf{D} \vee \mathbf{F}$  in Figure 2]; Figure 20).

(Gen) [111111, 111111, 111111, 111111, 111211, 113116]

(Bas)  $x^3 \approx x^2, xy^2 \approx yx^2, ax^2b \approx axb$

$$\text{(Max)} \quad x^2a \approx xa; \quad x^2y \approx xy^2$$

$$\text{(Dec)} \quad \text{var}\{J\} \vee \text{var}\{G_4\}$$

$$\text{(Sub)} \quad 10$$

**Variety 83** (Zhang and Luo [94, Variety  $\mathbf{E} \vee \mathbf{F}$  in Figure 2]; Figure 20).

$$\text{(Gen)} \quad [111111, 111111, 111111, 111114, 112111, 111116]$$

$$\text{(Bas)} \quad x^3 \approx x^2, \quad x^2y \approx y^2x, \quad ax^2b \approx axb$$

$$\text{(Max)} \quad ax^2 \approx ax; \quad x^2y \approx xy^2$$

$$\text{(Dec)} \quad \text{var}\{\overleftarrow{J}\} \vee \text{var}\{G_4\}$$

$$\text{(Sub)} \quad 10$$

**Variety 84** (Tishchenko [79, Variety  $\mathbf{V}_{2,3}$  on page 439]; Figure 25).

$$\text{(Gen)} \quad [111111, 111111, 111111, 112115, 555555, 666666]$$

$$\text{(Bas)} \quad x^3 \approx x^2, \quad xyx \approx xyz$$

$$\text{(Max)} \quad xyx \approx x^2; \quad xyx \approx xy$$

$$\text{(Dec)} \quad \text{var}\{G_4\} \vee \text{var}\{P_2\}$$

$$\text{(Sub)} \quad 9$$

**Variety 85** (Dual of Variety 84; Figure 25).

$$\text{(Gen)} \quad [111156, 111156, 111156, 112156, 111156, 111556]$$

$$\text{(Bas)} \quad x^3 \approx x^2, \quad xyx \approx zyx$$

$$\text{(Max)} \quad xyx \approx x^2; \quad xyx \approx yx$$

$$\text{(Dec)} \quad \text{var}\{G_4\} \vee \text{var}\{\overleftarrow{P}_2\}$$

$$\text{(Sub)} \quad 9$$

**Variety 86** (Mel'nik [54, Variety  $B_{24}$  in Figure 3]; Figure 30).

$$\text{(Gen)} \quad [1111111, 1111111, 1111112, 1111121, 1111122, 1112235, 1121254]$$

$$\text{(Bas)} \quad x^3 \approx xyzt, \quad x^2y \approx xy^2, \quad xy \approx yx$$

$$\text{(Max)} \quad x^2y \approx x^3$$

(Dec) None

(Sub) 7

**Variety 87** (Mel'nik [54, Variety  $B_{26}$  in Figure 3]; Figure 30).

(Gen) [1111 1111, 1111 1111, 1111 1112, 1111 1121, 1111 1211, 1111 2134,  
1112 1315, 1121 1451]

(Bas)  $x^2 \approx xyz$ ,  $xy \approx yx$

(Max)  $x^2 \approx xyz$

(Dec) None

(Sub) 4

**Variety 88** (Mel'nik [54, Variety  $B_{25}$  in Figure 3]; Figure 30).

(Gen) [1111 1111, 1111 1111, 1111 1112, 1111 1121, 1111 1211, 1111 2134,  
1112 1315, 1121 1452]

(Bas)  $x^2y \approx xyz$ ,  $xy \approx yx$

(Max)  $x^3 \approx xyz$ ;  $x^3 \approx x^2$

(Dec)  $\text{var}\{N_3\} \vee \mathbf{V}_{87}$

(Sub) 6

## 7 Problems

In this section we propose a number of problems that are naturally prompted by the results in this paper.

**Small varieties** A variety that contains only finitely many subvarieties is said to be *small*. The variety generated by any finite group is Cross and so also small [58]. But very little is known about small varieties generated by a finite semigroup that is not a group; see Proposition 2.1.

**Problem 7.1.** Characterize finite semigroups that generate small varieties.

The class of small varieties is not closed under the formation of joins: there exist finitely generated small varieties  $\mathbf{V}_1$  and  $\mathbf{V}_2$  whose join  $\mathbf{V}_1 \vee \mathbf{V}_2$  contains countably infinitely many subvarieties [65].

**Problem 7.2** (Jackson [22, Question 3.15]). Find two finitely generated small varieties  $\mathbf{V}_1$  and  $\mathbf{V}_2$  whose join  $\mathbf{V}_1 \vee \mathbf{V}_2$  contains continuum many subvarieties.

**Finitely universal varieties** Recall that a variety is *finitely universal* if its lattice of subvarieties embeds every finite lattice; see Subsection 2.5. Vernikov and Volkov [88] proved that the variety  $\mathbf{H} = [x^2 \approx yxy]$  is finitely universal. So far, all known examples of finitely generated finitely universal variety contains  $\mathbf{H}$ .

**Problem 7.3.** Find a finitely generated finitely universal variety  $\mathbf{V}$  such that  $\mathbf{H} \not\subseteq \mathbf{V}$ .

It turns out that every example of finitely generated variety with continuum many subvarieties discovered so far is also finitely universal. It is thus of interest to find a counterexample.

**Problem 7.4.** Find a finitely generated variety with continuum many subvarieties that is not finitely universal.

**Problem 7.5.** Find two finitely generated small varieties  $\mathbf{V}_1$  and  $\mathbf{V}_2$  whose join  $\mathbf{V}_1 \vee \mathbf{V}_2$  is finitely universal.

**Problem 7.6.** Characterize finite semigroups that generate finitely universal varieties.

**Identity bases** The varieties  $\text{var}\{B_2^1\}$ ,  $\text{var}\{A_2^1\}$ ,  $\text{var}\{A_2^g\}$ , and  $\text{var}\{L_3\}$  are exactly all non-finitely based varieties generated by a semigroup of order 6, and that explicit identity bases have been found for the latter two varieties (see Propositions 4.2 and 4.3); to do the same for the former two varieties seems challenging.

**Problem 7.7.** Find explicit identity bases for the varieties  $\text{var}\{B_2^1\}$  and  $\text{var}\{A_2^1\}$ .

**Problem 7.8.** Solve the finite basis problem for semigroups of order 7.

The number of varieties generated by a semigroup of order 5 or less is 218, while the number of varieties generated by a semigroup of order 6 is at least 463; see Table 4. Of these, 49 varieties are known (45 finitely-based and 4 non-finitely based). Therefore the next problem contains in fact at least 414 different problems.

**Problem 7.9.** Identify all varieties generated by a semigroup of order 6.

In the companion website, tab *Conjectures*, you can find a table which presents the results of running algorithms (A) and (B) (on page ??) against

order 6 semigroups.

There are 28634 nonisomorphic semigroups of order 6, and from these, there are 2035 whose varieties do not coincide to any known variety generated by semigroups of order up to 5. Using the above referred algorithm (A), it was possible to divide these 2035 semigroups into 463 sets of semigroups that satisfy the same identities, corresponding to 414 new proposed varieties (since there are 45 known finitely-based and 4 known non-finitely based varieties generated by semigroups of order 6). The site's tab *Conjectures* referred to above contains all these 463 conjectures, each one of them a research problem in itself.

The same methodology can be extended to order 7 semigroups. There are 73807 order 7 nonisomorphic semigroups whose varieties do not coincide with known varieties stored in our database.

**Groups** Regarding groups we propose the following problems.

**Problem 7.10.** Given a finite group  $G$ , find good bounds for the following:

- (a) the number of critical groups in  $\text{var}\{G\}$ ;
- (b) the order of the largest critical group in  $\text{var}\{G\}$ ;
- (c) the number of subvarieties of  $\text{var}\{G\}$ ;
- (d) the number of varieties covered by  $\text{var}\{G\}$ .

Solve the same problems for the class  $\mathbf{C}(e, m, c)$  introduced in Subsection 3.7.

Bases for the varieties generated by dihedral groups are known. However we need also the varieties covered by them (see (b) on page 11). The dihedral groups of order  $2n$  and  $4n$  (with  $n$  odd) belong to  $\mathbf{A}_n\mathbf{A}_2$ . Therefore Houghton's Theorem (see page 28) solves the problem of finding the subvarieties. But for the other cases the problem is open.

**Problem 7.11.** Find all the varieties covered by a variety generated by a dihedral group, and provide a base of identities for each.

The smallest non-decided case is the order 16 dihedral group.

Besides dihedral groups, bases of identities are known for many other groups [8, 9, 73]. Therefore the previous problem carries to them as well.

**Problem 7.12.** Let  $G$  be a group for which a base of identities is known and let  $V$  be the variety it generates. Find all the varieties covered by  $V$  and provide a base of identities for each.

## A Basic results on identities of some semi-groups

The present section establishes some background equational results that are required in Sections B and C. For more information on universal algebra, refer to the monograph of Burris and Sankappanavar [7].

Words are formed over some countably infinite set  $\mathcal{X}$  of variables. An *identity* is an expression  $\mathbf{u} \approx \mathbf{v}$  where  $\mathbf{u}, \mathbf{v} \in \mathcal{X}^+$ . An identity  $\mathbf{u} \approx \mathbf{v}$  is *nontrivial* if  $\mathbf{u} \neq \mathbf{v}$ . A semigroup  $S$  *satisfies* an identity  $\mathbf{u} \approx \mathbf{v}$  if for any substitution  $\varphi : \mathcal{X} \rightarrow S$ , the elements  $\varphi(\mathbf{u})$  and  $\varphi(\mathbf{v})$  of  $S$  are equal; otherwise,  $S$  *violates*  $\mathbf{u} \approx \mathbf{v}$ . An identity  $\mathbf{u} \approx \mathbf{v}$  is *deducible* from some identity  $\mathbf{u}' \approx \mathbf{v}'$  if there exist some substitution  $\varphi : \mathcal{X} \rightarrow \mathcal{X}^+$  and some words  $\mathbf{p}, \mathbf{q} \in \mathcal{X}^*$  such that  $\mathbf{u} = \mathbf{p}(\varphi(\mathbf{u}'))\mathbf{q}$  and  $\mathbf{v} = \mathbf{p}(\varphi(\mathbf{v}'))\mathbf{q}$ . An identity  $\mathbf{u} \approx \mathbf{v}$  is *deducible* from some set  $\Sigma$  of identities if there exists some sequence

$$\mathbf{u} = \mathbf{w}_0, \mathbf{w}_1, \dots, \mathbf{w}_m = \mathbf{v}$$

of words where each identity  $\mathbf{w}_i \approx \mathbf{w}_{i+1}$  is deducible from some identity in  $\Sigma$ .

For any word  $\mathbf{w}$ ,

- the *head* of  $\mathbf{w}$ , denoted by  $\mathbf{h}(\mathbf{w})$ , is the first variable occurring in  $\mathbf{w}$ ;
- the *tail* of  $\mathbf{w}$ , denoted by  $\mathbf{t}(\mathbf{w})$ , is the last variable occurring in  $\mathbf{w}$ ;
- the *initial part* of  $\mathbf{w}$ , denoted by  $\mathbf{ini}(\mathbf{w})$ , is the word obtained by retaining the first occurrence of each variable in  $\mathbf{w}$ ;
- the *content* of  $\mathbf{w}$ , denoted by  $\mathbf{con}(\mathbf{w})$ , is the set of variables occurring in  $\mathbf{w}$ ;
- the number of occurrences of a variable  $x$  in  $\mathbf{w}$  is denoted by  $\mathbf{occ}(x, \mathbf{w})$ .

**Lemma A.1.** *Let  $\mathbf{u} \approx \mathbf{v}$  be any identity. Then*

- (i)  $LZ_2$  satisfies  $\mathbf{u} \approx \mathbf{v}$  if and only if  $\mathbf{h}(\mathbf{u}) = \mathbf{h}(\mathbf{v})$ ;
- (ii)  $LZ_2^1$  satisfies  $\mathbf{u} \approx \mathbf{v}$  if and only if  $\mathbf{ini}(\mathbf{u}) = \mathbf{ini}(\mathbf{v})$ ;
- (iii)  $N_3$  satisfies  $\mathbf{u} \approx \mathbf{v}$  if and only if either

$$|\mathbf{u}|, |\mathbf{v}| \geq 3 \quad \text{or} \quad \mathbf{occ}(x, \mathbf{u}) = \mathbf{occ}(x, \mathbf{v}) \text{ for all } x \in \mathcal{X};$$

- (iv)  $N_n^1$  satisfies  $\mathbf{u} \approx \mathbf{v}$  if and only if for all  $x \in \mathcal{X}$ , either

$$\mathbf{occ}(x, \mathbf{u}) = \mathbf{occ}(x, \mathbf{v}) < n \quad \text{or} \quad \mathbf{occ}(x, \mathbf{u}), \mathbf{occ}(x, \mathbf{v}) \geq n;$$

(v)  $\mathbb{Z}_n$  satisfies  $\mathbf{u} \approx \mathbf{v}$  if and only if  $\text{occ}(x, \mathbf{u}) \equiv \text{occ}(x, \mathbf{v}) \pmod{n}$  for all  $x \in \mathcal{X}$ .

*Proof.* These results are well-known and easily verified. For instance, see Petrich and Reilly [62, Theorem V.1.9] for parts (i) and (ii) and Almeida [1, Lemma 6.1.4] for parts (iv) and (v).  $\square$

**Lemma A.2.** *Let  $\mathbf{W}$  be any variety that satisfies the identity*

$$x^{n+k} \approx x^n \tag{A.1}$$

for some  $n \geq 2$  and  $k \geq 1$ . Suppose that  $N_n^1 \notin \mathbf{W}$ . Then  $\mathbf{W}$  satisfies the identity

$$(x^n y)^{n-1+k} x^n \approx (x^n y)^{n-1} x^n. \tag{A.2}$$

*Proof.* By assumption, the variety  $\mathbf{W}$  satisfies some identity  $\alpha : \mathbf{u} \approx \mathbf{v}$  that is violated by the semigroup  $N_n^1$ . In view of Lemma A.1(iv), generality is not lost by assuming the existence of some variable  $y \in \mathcal{X}$  such that  $\text{occ}(y, \mathbf{u}) = r < n$  and  $\text{occ}(y, \mathbf{v}) = s > r$ . Then

$$\mathbf{u} = \mathbf{u}_0 y \mathbf{u}_1 y \mathbf{u}_2 \cdots y \mathbf{u}_r \quad \text{and} \quad \mathbf{v} = \mathbf{v}_0 y \mathbf{v}_1 y \mathbf{v}_2 \cdots y \mathbf{v}_s$$

for some  $\mathbf{u}_i, \mathbf{v}_j \in \mathcal{X}^*$  such that  $y \notin \text{con}(\mathbf{u}_i \mathbf{v}_j)$ . Let  $\varphi$  denote the substitution that maps  $y$  to  $x^n y$  and every other variable to  $x^k$ . Then since

$$(x^n y)^r x^n \stackrel{(A.1)}{\approx} (\varphi(\mathbf{u})) x^n \stackrel{\alpha}{\approx} (\varphi(\mathbf{v})) x^n \stackrel{(A.1)}{\approx} (x^n y)^s x^n,$$

the variety  $\mathbf{W}$  satisfies the identity  $(x^n y)^r x^n \approx (x^n y)^s x^n$ . It follows that  $\mathbf{W}$  satisfies the identity  $\beta : (x^n y)^{n-1} x^n \approx (x^n y)^{n-1+t} x^n$  for some  $t \geq 1$ . Since

$$\begin{aligned} (x^n y)^{n-1} x^n &\stackrel{\beta}{\approx} (x^n y)^{n-1+t} x^n \stackrel{\beta}{\approx} (x^n y)^{n-1+2t} x^n \stackrel{\beta}{\approx} \dots \\ &\stackrel{\beta}{\approx} (x^n y)^{n-1+kt} x^n \stackrel{(A.1)}{\approx} (x^n y)^{n-1+k} x^n, \end{aligned}$$

the variety  $\mathbf{W}$  also satisfies the identity (A.2).  $\square$

**Lemma A.3** (Golubov and Sapir [18, Lemma 7]). *The semigroup  $J$  satisfies an identity  $\mathbf{u} \approx \mathbf{v}$  if and only if  $\text{con}(\mathbf{u}) = \text{con}(\mathbf{v})$  and either of the following conditions holds:*

- (i)  $\text{occ}(\mathbf{t}(\mathbf{u}), \mathbf{u}) = \text{occ}(\mathbf{t}(\mathbf{v}), \mathbf{v}) = 1$  with  $\mathbf{t}(\mathbf{u}) = \mathbf{t}(\mathbf{v})$ ;
- (ii)  $\text{occ}(\mathbf{t}(\mathbf{u}), \mathbf{u}), \text{occ}(\mathbf{t}(\mathbf{v}), \mathbf{v}) \geq 2$ .

**Lemma A.4.** *Let  $\mathbf{W}$  be any variety that satisfies the identity*

$$x^{2n} \approx x^n \quad (\text{A.3})$$

for some  $n \geq 2$ . Suppose that  $J \notin \mathbf{W}$ . Then  $\mathbf{W}$  satisfies one of the identities

$$(x^n y)^{n+1} \approx x^n y, \quad (\text{A.4})$$

$$x^n y x^n \approx x^n y. \quad (\text{A.5})$$

*Proof.* By assumption, the variety  $\mathbf{W}$  satisfies an identity  $\alpha : \mathbf{u} \approx \mathbf{v}$  that is violated by the semigroup  $J$ . It is well known and easily shown that if  $\text{con}(\mathbf{u}) \neq \text{con}(\mathbf{v})$ , then the identity  $(x^n y)^n x^n \approx x^n$  is deducible from the identities  $\{(\text{A.3}), \mathbf{u} \approx \mathbf{v}\}$  and so is satisfied by the variety  $\mathbf{W}$ , whence  $\mathbf{W}$  also satisfies the identity (A.4). Therefore assume that  $\text{con}(\mathbf{u}) = \text{con}(\mathbf{v})$ . By Lemma A.3, there are two cases.

CASE 1:  $\mathbf{t}(\mathbf{u}) = \mathbf{t}(\mathbf{v}) = y$  with  $\text{occ}(y, \mathbf{u}) = 1$  and  $\text{occ}(y, \mathbf{v}) = m \geq 2$ . Then

$$\mathbf{u} = \mathbf{w}_0 y \quad \text{and} \quad \mathbf{v} = \mathbf{w}_1 y \mathbf{w}_2 y \cdots \mathbf{w}_m y$$

for some  $\mathbf{w}_i \in \mathcal{X}^*$  such that  $y \notin \text{con}(\mathbf{w}_i)$ . Let  $\varphi$  denote the substitution that maps  $y$  to  $x^n y$  and every other variable to  $x^n$ . Then

$$x^n y \stackrel{(\text{A.3})}{\approx} x^n(\varphi(\mathbf{u})) \stackrel{\alpha}{\approx} x^n(\varphi(\mathbf{v})) \stackrel{(\text{A.3})}{\approx} (x^n y)^m,$$

so that  $\mathbf{W}$  satisfies the identity  $\beta : x^n y \approx (x^n y)^{\ell+1}$  with  $\ell = m - 1$ . Since

$$x^n y \stackrel{\beta}{\approx} (x^n y)^{\ell+1} \stackrel{\beta}{\approx} (x^n y)^{2\ell+1} \stackrel{\beta}{\approx} \cdots \stackrel{\beta}{\approx} (x^n y)^{n\ell+1} \stackrel{(\text{A.3})}{\approx} (x^n y)^{n+1},$$

the variety  $\mathbf{W}$  also satisfies the identity (A.4).

CASE 2:  $\mathbf{t}(\mathbf{u}) = y \neq z = \mathbf{t}(\mathbf{v})$  with  $\text{occ}(y, \mathbf{u}) = 1$  and  $\text{occ}(z, \mathbf{v}) \geq 1$ . The assumption  $\text{con}(\mathbf{u}) = \text{con}(\mathbf{v})$  implies that  $\text{occ}(y, \mathbf{v}) = m \geq 1$ . Then

$$\mathbf{u} = \mathbf{w}_0 y \quad \text{and} \quad \mathbf{v} = \mathbf{w}_1 y \mathbf{w}_2 y \cdots \mathbf{w}_m y \mathbf{w}_{m+1} z$$

for some  $\mathbf{w}_i \in \mathcal{X}$  such that  $y \notin \text{con}(\mathbf{w}_i)$ . Let  $\varphi$  denote the substitution in Case 1. Then

$$x^n y \stackrel{(\text{A.3})}{\approx} x^n(\varphi(\mathbf{u})) \stackrel{\alpha}{\approx} x^n(\varphi(\mathbf{v})) \stackrel{(\text{A.3})}{\approx} (x^n y)^m x^n,$$

so that  $\mathbf{W}$  satisfies the identity  $\gamma : x^n y \approx (x^n y)^m x^n$ . Since

$$x^n(yx^n) \stackrel{\gamma}{\approx} (x^n(yx^n))^m x^n \stackrel{(\text{A.3})}{\approx} (x^n y)^m x^n \stackrel{\gamma}{\approx} x^n y,$$

the variety  $\mathbf{W}$  also satisfies the identity (A.5).  $\square$

**Lemma A.5.** *A variety that contains only finitely based subvarieties, contains at most countably many subvarieties.*

*Proof.* Up to renaming of variables, there can only be countably many finite sets of identities.  $\square$

## B Some finite lattices of varieties

### B.1 Subvarieties of $\mathbf{V}_{24} = \text{var}\{J, \overleftarrow{J}\}$

**Proposition B.1** (Zhang and Luo [94, Figure 2]).

(i) *The proper nontrivial subvarieties of  $\mathbf{V}_{24} = \text{var}\{J, \overleftarrow{J}\}$  are*

$$\begin{aligned} \mathbf{V}_1 &= \text{var}\{N_2\}, & \mathbf{V}_2 &= \text{var}\{Sl_2\}, & \mathbf{V}_7 &= \text{var}\{N_2, Sl_2\}, \\ \mathbf{V}_8 &= \text{var}\{J\}, & \mathbf{V}_{10} &= \text{var}\{\overleftarrow{J}\}, & \mathbf{V}_{20} &= \text{var}\{F_4\}, \\ \mathbf{V}_{22} &= \text{var}\{G_4\}, & \mathbf{V}_{73} &= \text{var}\{Sl_2, F_4\}, & \mathbf{V}_{76} &= \text{var}\{Sl_2, G_4\}, \\ \mathbf{V}_{82} &= \text{var}\{J, G_4\}, & \mathbf{V}_{83} &= \text{var}\{\overleftarrow{J}, G_4\}. \end{aligned}$$

(ii) *The lattice  $\mathcal{L}(\mathbf{V}_{24})$  is given in Figure 20.*

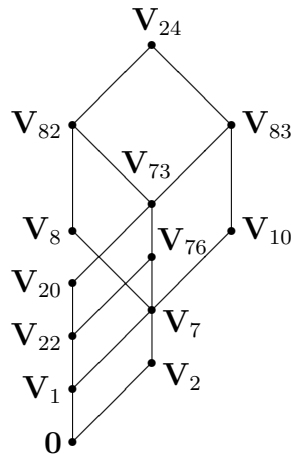

Figure 20: The lattice  $\mathcal{L}(\mathbf{V}_{24})$

### B.2 Subvarieties of $\mathbf{V}_{79} = \text{var}\{LZ_2^1, RZ_2^1\}$

**Proposition B.2** (Gerhard and Petrich [16, Section 2]).

(i) *The proper nontrivial subvarieties of  $\mathbf{V}_{79} = \text{var}\{LZ_2^1, RZ_2^1\}$  are*

$$\begin{aligned} \mathbf{V}_2 &= \text{var}\{Sl_2\}, & \mathbf{V}_3 &= \text{var}\{LZ_2\}, & \mathbf{V}_4 &= \text{var}\{RZ_2\}, \\ \mathbf{V}_{12} &= \text{var}\{Sl_2, LZ_2\}, & \mathbf{V}_{13} &= \text{var}\{Sl_2, RZ_2\}, & \mathbf{V}_{15} &= \text{var}\{LZ_2^1\}, \\ \mathbf{V}_{18} &= \text{var}\{RZ_2^1\}, & \mathbf{V}_{51} &= \text{var}\{Sl_2, LZ_2, RZ_2\}, & \mathbf{V}_{53} &= \text{var}\{RZ_2, LZ_2^1\}, \\ \mathbf{V}_{63} &= \text{var}\{LZ_2, RZ_2^1\}, & \mathbf{V}_{67} &= \text{var}\{LZ_2, RZ_2\}. \end{aligned}$$

(ii) The lattice  $\mathcal{L}(\mathbf{V}_{79})$  is given in Figure 21.

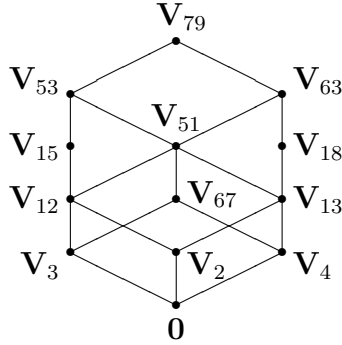

Figure 21: The lattice  $\mathcal{L}(\mathbf{V}_{79})$

### B.3 Subvarieties of $\mathbf{V}_{35} = \text{var}\{J, LZ_2^1\}$ and $\mathbf{V}_{61} = \text{var}\{\overleftarrow{J}, RZ_2^1\}$

**Proposition B.3** (Zhang and Luo [94, Subvarieties of  $\mathbf{A}$  in Figure 5]).

(i) The proper nontrivial subvarieties of  $\mathbf{V}_{35} = \text{var}\{J, LZ_2^1\}$  are

$$\begin{aligned} \mathbf{V}_1 &= \text{var}\{N_2\}, & \mathbf{V}_2 &= \text{var}\{Sl_2\}, & \mathbf{V}_3 &= \text{var}\{LZ_2\}, \\ \mathbf{V}_7 &= \text{var}\{N_2, Sl_2\}, & \mathbf{V}_8 &= \text{var}\{J\}, & \mathbf{V}_9 &= \text{var}\{N_2, LZ_2\}, \\ \mathbf{V}_{12} &= \text{var}\{Sl_2, LZ_2\}, & \mathbf{V}_{15} &= \text{var}\{LZ_2^1\}, & \mathbf{V}_{28} &= \text{var}\{N_2, Sl_2, LZ_2\}, \\ \mathbf{V}_{31} &= \text{var}\{N_2, LZ_2^1\}, & \mathbf{V}_{32} &= \text{var}\{LZ_2, J\}. \end{aligned}$$

(ii) The proper nontrivial subvarieties of  $\mathbf{V}_{61} = \text{var}\{\overleftarrow{J}, RZ_2^1\}$  are

$$\begin{aligned} \mathbf{V}_1 &= \text{var}\{N_2\}, & \mathbf{V}_2 &= \text{var}\{Sl_2\}, & \mathbf{V}_4 &= \text{var}\{RZ_2\}, \\ \mathbf{V}_7 &= \text{var}\{N_2, Sl_2\}, & \mathbf{V}_{10} &= \text{var}\{\overleftarrow{J}\}, & \mathbf{V}_{13} &= \text{var}\{Sl_2, RZ_2\}, \\ \mathbf{V}_{16} &= \text{var}\{N_2, RZ_2\}, & \mathbf{V}_{18} &= \text{var}\{RZ_2^1\}, & \mathbf{V}_{29} &= \text{var}\{N_2, Sl_2, RZ_2\}, \\ \mathbf{V}_{47} &= \text{var}\{RZ_2, \overleftarrow{J}\}, & \mathbf{V}_{59} &= \text{var}\{N_2, RZ_2^1\}. \end{aligned}$$

(iii) The lattices  $\mathcal{L}(\mathbf{V}_{35})$  and  $\mathcal{L}(\mathbf{V}_{61})$  are given in Figure 22.

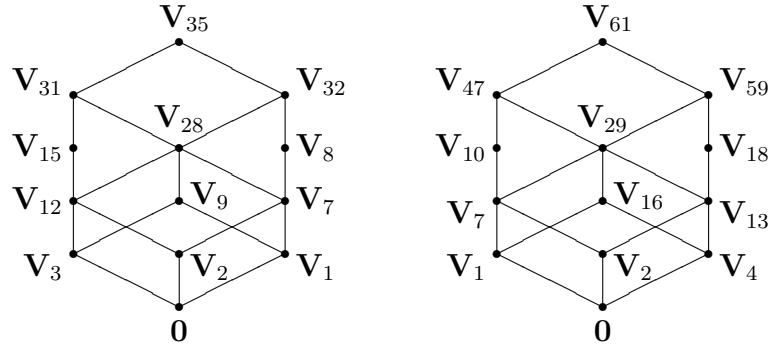

Figure 22: The lattices  $\mathcal{L}(\mathbf{V}_{35})$  and  $\mathcal{L}(\mathbf{V}_{61})$

#### B.4 Subvarieties of $\mathbf{V}_{42} = \text{var}\{\overleftarrow{J}, LZ_2^1\}$ and $\mathbf{V}_{60} = \text{var}\{J, RZ_2^1\}$

**Proposition B.4** (Zhang and Luo [94, Subvarieties of  $\mathbf{B}$  in Figure 5]).

(i) *The proper nontrivial subvarieties of  $\mathbf{V}_{42} = \text{var}\{\overleftarrow{J}, LZ_2^1\}$  are*

$$\begin{aligned} \mathbf{V}_1 &= \text{var}\{N_2\}, & \mathbf{V}_2 &= \text{var}\{Sl_2\}, & \mathbf{V}_3 &= \text{var}\{LZ_2\}, \\ \mathbf{V}_7 &= \text{var}\{N_2, Sl_2\}, & \mathbf{V}_9 &= \text{var}\{N_2, LZ_2\}, & \mathbf{V}_{10} &= \text{var}\{\overleftarrow{J}\}, \\ \mathbf{V}_{12} &= \text{var}\{Sl_2, LZ_2\}, & \mathbf{V}_{15} &= \text{var}\{LZ_2^1\}, & \mathbf{V}_{28} &= \text{var}\{N_2, Sl_2, LZ_2\}, \\ \mathbf{V}_{31} &= \text{var}\{N_2, LZ_2^1\}, & \mathbf{V}_{41} &= \text{var}\{LZ_2, \overleftarrow{J}\}, \\ \mathbf{V}_{78} &= \text{var}\{[11111, 11113, 11133, 11144, 11155]\}. \end{aligned}$$

(ii) *The proper nontrivial subvarieties of  $\mathbf{V}_{60} = \text{var}\{J, RZ_2^1\}$  are*

$$\begin{aligned} \mathbf{V}_1 &= \text{var}\{N_2\}, & \mathbf{V}_2 &= \text{var}\{Sl_2\}, & \mathbf{V}_4 &= \text{var}\{RZ_2\}, \\ \mathbf{V}_7 &= \text{var}\{N_2, Sl_2\}, & \mathbf{V}_8 &= \text{var}\{J\}, & \mathbf{V}_{13} &= \text{var}\{Sl_2, RZ_2\}, \\ \mathbf{V}_{16} &= \text{var}\{N_2, RZ_2\}, & \mathbf{V}_{18} &= \text{var}\{RZ_2^1\}, & \mathbf{V}_{29} &= \text{var}\{N_2, Sl_2, RZ_2\}, \\ \mathbf{V}_{33} &= \text{var}\{RZ_2, J\}, & \mathbf{V}_{59} &= \text{var}\{N_2, RZ_2^1\}, \\ \mathbf{V}_{75} &= \text{var}\{[11111, 11111, 11111, 11345, 13345]\}. \end{aligned}$$

(iii) *The lattices  $\mathcal{L}(\mathbf{V}_{42})$  and  $\mathcal{L}(\mathbf{V}_{60})$  are given in Figure 23.*

#### B.5 Subvarieties of $\mathbf{V}_{56} = \text{var}\{O_2\}$ and $\mathbf{V}_{66} = \text{var}\{\overleftarrow{O}_2\}$

**Proposition B.5** (Tishchenko [78, Figure 7]).

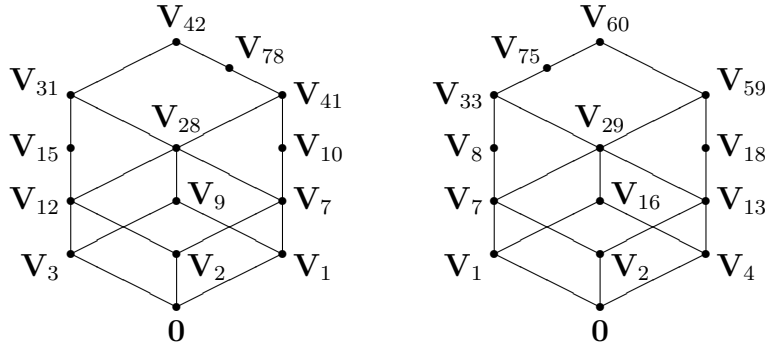

Figure 23: The lattices  $\mathcal{L}(\mathbf{V}_{42})$  and  $\mathcal{L}(\mathbf{V}_{60})$

(i) The proper nontrivial subvarieties of  $\mathbf{V}_{56} = \text{var}\{O_2\}$  are

$$\begin{aligned} \mathbf{V}_2 &= \text{var}\{Sl_2\}, & \mathbf{V}_3 &= \text{var}\{LZ_2\}, & \mathbf{V}_5 &= \text{var}\{\mathbb{Z}_2\}, \\ \mathbf{V}_{12} &= \text{var}\{Sl_2, LZ_2\}, & \mathbf{V}_{14} &= \text{var}\{Sl_2, \mathbb{Z}_2\}, & \mathbf{V}_{15} &= \text{var}\{LZ_2^1\}, \\ \mathbf{V}_{52} &= \text{var}\{Sl_2, LZ_2, \mathbb{Z}_2\}, & \mathbf{V}_{54} &= \text{var}\{\mathbb{Z}_2, LZ_2^1\}, & \mathbf{V}_{68} &= \text{var}\{LZ_2, \mathbb{Z}_2\}. \end{aligned}$$

(ii) The proper nontrivial subvarieties of  $\mathbf{V}_{66} = \text{var}\{\overleftarrow{O}_2\}$  are

$$\begin{aligned} \mathbf{V}_2 &= \text{var}\{Sl_2\}, & \mathbf{V}_4 &= \text{var}\{RZ_2\}, & \mathbf{V}_5 &= \text{var}\{\mathbb{Z}_2\}, \\ \mathbf{V}_{13} &= \text{var}\{Sl_2, RZ_2\}, & \mathbf{V}_{14} &= \text{var}\{Sl_2, \mathbb{Z}_2\}, & \mathbf{V}_{18} &= \text{var}\{RZ_2^1\}, \\ \mathbf{V}_{64} &= \text{var}\{Sl_2, RZ_2, \mathbb{Z}_2\}, & \mathbf{V}_{65} &= \text{var}\{\mathbb{Z}_2, RZ_2^1\}, & \mathbf{V}_{71} &= \text{var}\{RZ_2, \mathbb{Z}_2\}. \end{aligned}$$

(iii) The lattices  $\mathcal{L}(\mathbf{V}_{56})$  and  $\mathcal{L}(\mathbf{V}_{66})$  are given in Figure 24.

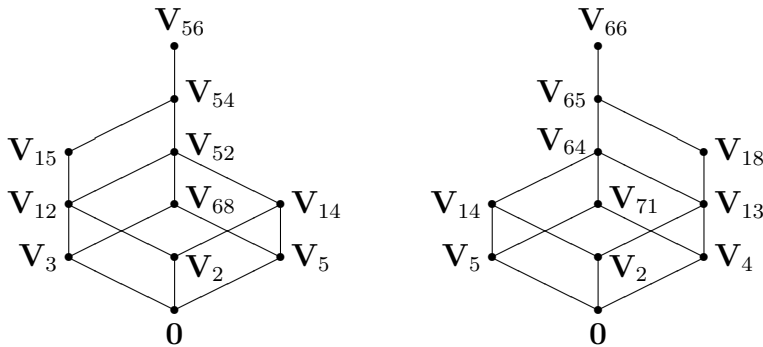

Figure 24: The lattices  $\mathcal{L}(\mathbf{V}_{56})$  and  $\mathcal{L}(\mathbf{V}_{66})$

### B.6 Subvarieties of $\mathbf{V}_{77} = \text{var}\{N_3, P_2\}$ and $\mathbf{V}_{81} = \text{var}\{N_3, \overleftarrow{P_2}\}$

**Proposition B.6** (Tishchenko [79, Figure 1]).

(i) *The proper nontrivial subvarieties of  $\mathbf{V}_{77} = \text{var}\{N_3, P_2\}$  are*

$$\begin{aligned} \mathbf{V}_1 &= \text{var}\{N_2\}, & \mathbf{V}_3 &= \text{var}\{LZ_2\}, & \mathbf{V}_6 &= \text{var}\{N_3\}, \\ \mathbf{V}_9 &= \text{var}\{N_2, LZ_2\}, & \mathbf{V}_{20} &= \text{var}\{F_4\}, & \mathbf{V}_{21} &= \text{var}\{N_3, F_4\}, \\ \mathbf{V}_{22} &= \text{var}\{G_4\}, & \mathbf{V}_{27} &= \text{var}\{LZ_2, N_3\}, & \mathbf{V}_{45} &= \text{var}\{P_2\}, \\ \mathbf{V}_{74} &= \text{var}\{LZ_2, G_4\}, & \mathbf{V}_{84} &= \text{var}\{G_4, P_2\}. \end{aligned}$$

(ii) *The proper nontrivial subvarieties of  $\mathbf{V}_{81} = \text{var}\{N_3, \overleftarrow{P_2}\}$  are*

$$\begin{aligned} \mathbf{V}_1 &= \text{var}\{N_2\}, & \mathbf{V}_4 &= \text{var}\{RZ_2\}, & \mathbf{V}_6 &= \text{var}\{N_3\}, \\ \mathbf{V}_{16} &= \text{var}\{N_2, RZ_2\}, & \mathbf{V}_{20} &= \text{var}\{F_4\}, & \mathbf{V}_{21} &= \text{var}\{N_3, F_4\}, \\ \mathbf{V}_{22} &= \text{var}\{G_4\}, & \mathbf{V}_{57} &= \text{var}\{RZ_2, N_3\}, & \mathbf{V}_{69} &= \text{var}\{\overleftarrow{P_2}\}, \\ \mathbf{V}_{80} &= \text{var}\{RZ_2, G_4\}, & \mathbf{V}_{85} &= \text{var}\{G_4, \overleftarrow{P_2}\}. \end{aligned}$$

(iii) *The lattices  $\mathcal{L}(\mathbf{V}_{77})$  and  $\mathcal{L}(\mathbf{V}_{81})$  are given in Figure 25.*

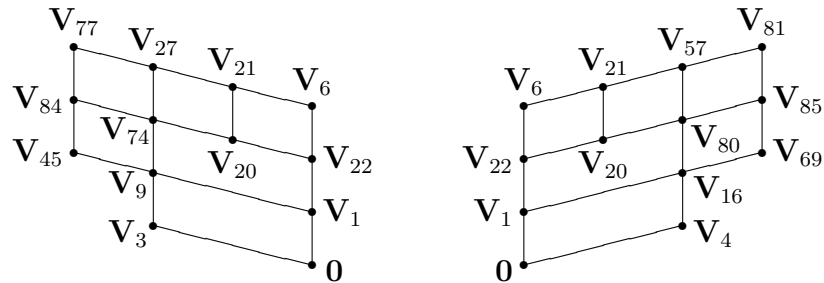

Figure 25: The lattices  $\mathcal{L}(\mathbf{V}_{77})$  and  $\mathcal{L}(\mathbf{V}_{81})$

### B.7 Subvarieties of $\mathbf{V}_{26} = \text{var}\{Sl_2, N_3\}$

**Lemma B.7** (Vernikov [86, Lemma 1.3]). *Let  $\mathbf{V}$  be any variety such that  $Sl_2 \notin \mathbf{V}$ .*

(i) *The lattice  $\mathcal{L}(\mathbf{V})$  is isomorphic to the interval*

$$\mathcal{I} = [\text{var}\{Sl_2\}, \text{var}\{Sl_2\} \vee \mathbf{V}].$$

(ii) The lattice  $\mathcal{L}(\text{var}\{Sl_2\} \vee \mathbf{V})$  is isomorphic to the direct product

$$\mathcal{L}(\text{var}\{Sl_2\}) \times \mathcal{L}(\mathbf{V}).$$

Consequently,  $\mathcal{L}(\text{var}\{Sl_2\} \vee \mathbf{V})$  is the disjoint union of  $\mathcal{L}(\mathbf{V})$  and  $\mathcal{I}$ .

**Proposition B.8.** The lattice  $\mathbf{V}_{26} = \text{var}\{Sl_2, N_3\}$  is given in Figure 26.

*Proof.* By Proposition B.6, the subvarieties of  $\mathbf{V}_6 = \text{var}\{N_3\}$  constitute the chain  $\mathbf{0} \subset \mathbf{V}_1 \subset \mathbf{V}_{22} \subset \mathbf{V}_6$ . Since  $\mathbf{V}_{26} = \text{var}\{Sl_2\} \vee \text{var}\{N_3\}$ , the result follows from Lemma B.7.  $\square$

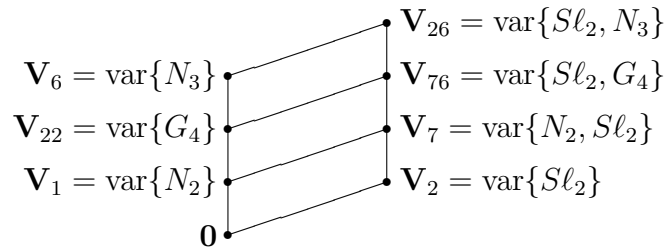

Figure 26: The lattice  $\mathcal{L}(\mathbf{V}_{26})$

## B.8 Subvarieties of $\text{var}\{N_3, \mathbb{Z}_n\}$

**Lemma B.9.** Let  $n \geq 1$  be any integer.

(i) The lattice  $\mathcal{L}(\text{var}\{N_3, \mathbb{Z}_n\})$  is isomorphic to the direct product

$$\mathcal{L}(\text{var}\{N_3\}) \times \mathcal{L}(\text{var}\{\mathbb{Z}_n\}).$$

Consequently,  $\mathcal{L}(\text{var}\{N_3, \mathbb{Z}_n\})$  is the disjoint union of the intervals

$$\mathcal{I}_d = [\text{var}\{\mathbb{Z}_d\}, \text{var}\{N_3, \mathbb{Z}_d\}],$$

where  $d$  ranges over all divisors of  $n$ .

(ii) The interval  $\mathcal{I}_d$  coincides with the chain

$$\text{var}\{\mathbb{Z}_d\} \subset \text{var}\{N_2, \mathbb{Z}_d\} \subset \text{var}\{G_4, \mathbb{Z}_d\} \subset \text{var}\{N_3, \mathbb{Z}_d\}.$$

*Proof.* (i) This follows from Vernikov [85, Proposition 2].

(ii) This follows from part (i) since by Figure 26, the lattice  $\mathcal{L}(\text{var}\{N_3\})$  coincides with the chain  $\mathbf{0} \subset \text{var}\{N_2\} \subset \text{var}\{G_4\} \subset \text{var}\{N_3\}$ .  $\square$

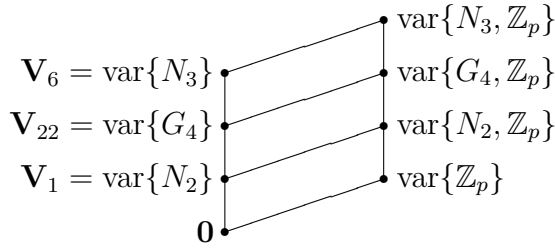

Figure 27: The lattice  $\mathcal{L}(\text{var}\{N_3, \mathbb{Z}_p\})$  with prime  $p \geq 2$

**Proposition B.10.** *For any prime  $p \geq 2$ , the lattice  $\mathcal{L}(\text{var}\{N_3, \mathbb{Z}_p\})$  is given in Figure 27.*

*Proof.* This follows from Lemma B.9. □

**Proposition B.11.** *Let  $n \geq 2$  be any integer. Then the identities*

$$x^n abc \approx abc, \tag{B.1a}$$

$$xy \approx yx \tag{B.1b}$$

*constitute an identity basis for the variety  $\text{var}\{N_3, \mathbb{Z}_n\}$ .*

*Proof.* It is routinely checked that the identities (B.1) are satisfied by the variety  $\text{var}\{N_3, \mathbb{Z}_n\}$ . Therefore it remains to show that any nontrivial identity  $\mathbf{u} \approx \mathbf{v}$  satisfied by  $\text{var}\{N_3, \mathbb{Z}_n\}$  is deducible from (B.1). By Lemma A.1 parts (iii) and (v), the following properties hold:

- (a) either  $|\mathbf{u}|, |\mathbf{v}| \geq 3$  or  $\text{occ}(x, \mathbf{u}) = \text{occ}(x, \mathbf{v})$  for all  $x \in \mathcal{X}$ ;
- (b)  $\text{occ}(x, \mathbf{u}) \equiv \text{occ}(x, \mathbf{v}) \pmod{n}$  for all variables  $x$ .

If  $\text{occ}(x, \mathbf{u}) = \text{occ}(x, \mathbf{v})$  for all  $x \in \mathcal{X}$ , then it is clear that the identity  $\mathbf{u} \approx \mathbf{v}$  is deducible from (B.1b). Therefore suppose that  $|\mathbf{u}|, |\mathbf{v}| \geq 3$ . Generality is not lost by assuming that  $\text{con}(\mathbf{u}) = \{x_1, x_2, \dots, x_k\}$  and  $\text{con}(\mathbf{v}) \setminus \text{con}(\mathbf{u}) = \{y_1, y_2, \dots, y_m\}$  for some  $k \geq 1$  and  $m \geq 0$ . Let  $e_i = \text{occ}(x_i, \mathbf{u})$ , so that  $\sum_{i=1}^k e_i = |\mathbf{u}| \geq 3$ . By (b), there exist  $r_i, s_j \geq 1$  such that  $\text{occ}(x_i, \mathbf{v}) = e_i + r_i n \geq 0$  and  $\text{occ}(y_j, \mathbf{v}) = s_j n \geq 0$ . Let  $r'_i \geq 1$  be any integer such that  $r_i + r'_i \geq 1$ . Then

$$\mathbf{v} \stackrel{\text{(B.1a)}}{\approx} \left( \prod_{i=1}^k x_i^{r'_i n} \right) \mathbf{v} \quad \text{since } |\mathbf{v}| \geq 3$$

$$\begin{aligned}
 & \stackrel{\text{(B.1b)}}{\approx} \left( \prod_{i=1}^k x_i^{r_i+r'_i} \prod_{i=1}^m y_i^{s_i} \right)^n \prod_{i=1}^k x_i^{e_i} \\
 & \stackrel{\text{(B.1a)}}{\approx} \prod_{i=1}^k x_i^{e_i} \quad \text{since } \sum_{i=1}^k e_i \geq 3 \\
 & \stackrel{\text{(B.1b)}}{\approx} \mathbf{u}. \quad \square
 \end{aligned}$$

**Proposition B.12.** *Let  $n \geq 2$  be any integer. Then the identities*

$$x^n abc \approx abc, \quad xy \approx yx, \quad x^{n+2} \approx x^2 \quad (\text{B.2})$$

*constitute an identity basis for the variety  $\text{var}\{G_4, \mathbb{Z}_n\}$ .*

*Proof.* Let  $\mathbf{W}$  denote the variety defined by the identities (B.2). Then it is routinely checked that the inclusions  $\text{var}\{G_4, \mathbb{Z}_n\} \subseteq \mathbf{W} \subseteq \text{var}\{N_3, \mathbb{Z}_n\}$  hold. But the semigroup  $N_3$  violates the last identity in (B.2), so that  $\mathbf{W} \neq \text{var}\{N_3, \mathbb{Z}_n\}$ . Therefore  $\mathbf{W} = \text{var}\{G_4, \mathbb{Z}_n\}$  by Lemma B.9(ii).  $\square$

## B.9 Subvarieties of $\text{var}\{J, \mathbb{Z}_p\}$ and $\text{var}\{Sl_2, \mathbb{Z}_{p^2}\}$

**Lemma B.13** (Sapir [65, Part (b) of the main theorem]). *Let  $\mathbf{G}$  be any periodic variety generated by a group. Then each subvariety of  $\text{var}\{J\} \vee \mathbf{G}$  is the join of some subvariety of  $\mathbf{G}$  with some of the following varieties:*

$$\mathbf{0}, \quad \mathbf{V}_1 = \text{var}\{N_2\}, \quad \mathbf{V}_2 = \text{var}\{Sl_2\}, \quad \mathbf{V}_8 = \text{var}\{J\}.$$

**Proposition B.14.** *Let  $p \geq 2$  be any prime.*

- (i) *The lattice  $\mathcal{L}(\text{var}\{J, \mathbb{Z}_p\})$  is given in Figure 28.*
- (ii) *The lattice  $\mathcal{L}(\text{var}\{Sl_2, \mathbb{Z}_{p^2}\})$  is given in Figure 29.*

*Proof.* This follows from Lemma B.13.  $\square$

**Proposition B.15.** *Let  $n \geq 2$  be any integer.*

- (i) *The identities*

$$x^{n+1}a \approx xa, \quad (\text{B.3a})$$

$$x^{m_1}y^{m_2} \approx y^{m_2}x^{m_1}, \quad m_1, m_2 \geq 2, \quad (\text{B.3b})$$

$$xya \approx yxa. \quad (\text{B.3c})$$

*constitute an identity basis for the variety  $\text{var}\{J, \mathbb{Z}_n\}$ .*

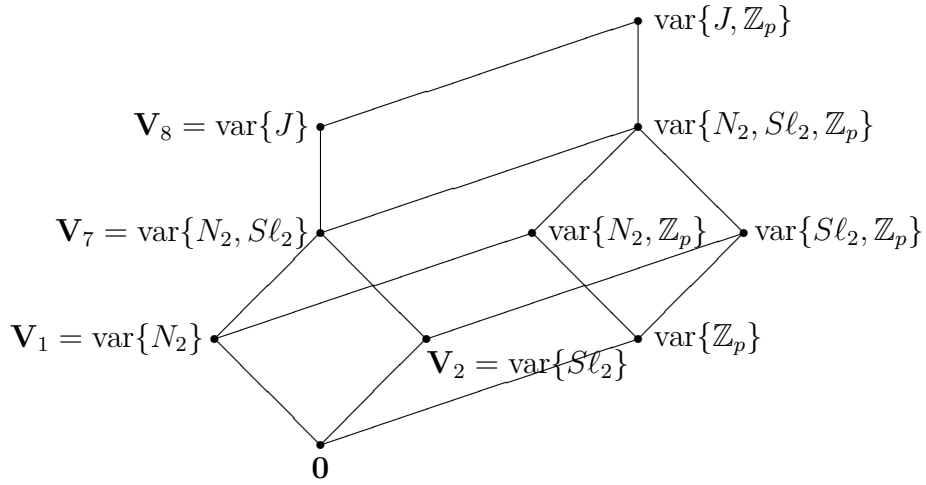

Figure 28: The lattice  $\mathcal{L}(\text{var}\{J, \mathbb{Z}_p\})$  with prime  $p \geq 2$

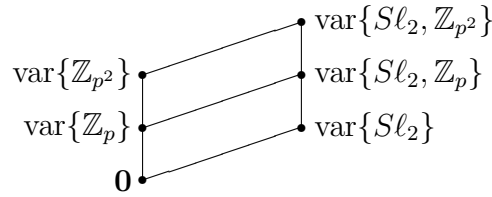

Figure 29: The lattice  $\mathcal{L}(\text{var}\{Sl_2, \mathbb{Z}_{p^2}\})$  with prime  $p \geq 2$

(ii) *The identities*

$$x^{n+1}a \approx xa, \quad x^2y^2 \approx y^2x^2, \quad xya \approx yxa$$

also constitute an identity basis for the variety  $\text{var}\{J, \mathbb{Z}_n\}$ .

*Proof.* (i) It is routinely checked that the identities (B.3) are satisfied by the variety  $\text{var}\{J, \mathbb{Z}_n\}$ . Therefore it remains to show that any identity  $\mathbf{u} \approx \mathbf{v}$  satisfied by  $\text{var}\{J, \mathbb{Z}_n\}$  is deducible from (B.3). By Lemma A.3, generality is not lost by assuming that  $\text{con}(\mathbf{u}) = \text{con}(\mathbf{v}) = \{x_1, x_2, \dots, x_m\}$ , so that  $e_i = \text{occ}(x_i, \mathbf{u}) \geq 1$  and  $f_i = \text{occ}(x_i, \mathbf{v}) \geq 1$ . Then  $e_i \equiv f_i \pmod{n}$  by Lemma A.1(v). By Lemma A.3, there are two cases.

CASE 1:  $\mathbf{t}(\mathbf{u}) = \mathbf{t}(\mathbf{v}) = x_k$  with either  $e_k = f_k = 1$  or  $e_k, f_k \geq 2$ . Then

$$\mathbf{u} \stackrel{\text{(B.3c)}}{\approx} \left( \prod_{i \neq k} x_i^{e_i} \right) x_k^{e_k}$$

$$\stackrel{\text{(B.3a)}}{\approx} \left( \prod_{i \neq k} x_i^{f_i} \right) x_k^{f_k} \quad \text{since } e_i \equiv f_i \pmod{n}$$

$$\stackrel{\text{(B.3c)}}{\approx} \mathbf{v}.$$

CASE 2:  $\mathbf{t}(\mathbf{u}) = x_k$  and  $\mathbf{t}(\mathbf{v}) = x_\ell$  with  $k < \ell$  and  $e_k, f_\ell \geq 2$ . Choose any integer  $g_i > \max\{e_i, f_i\}$  such that  $g_i \equiv e_i \equiv f_i \pmod{n}$ . Then

$$\mathbf{u} \stackrel{\text{(B.3c)}}{\approx} \left( \prod_{i \neq k, \ell} x_i^{e_i} \right) x_\ell^{e_\ell} x_k^{e_k}$$

$$\stackrel{\text{(B.3a)}}{\approx} \left( \prod_{i \neq k, \ell} x_i^{g_i} \right) x_\ell^{g_\ell} x_k^{g_k} \quad \text{since } g_i \equiv e_i \pmod{n} \text{ and } e_k \geq 2$$

$$\stackrel{\text{(B.3b)}}{\approx} \left( \prod_{i \neq k, \ell} x_i^{g_i} \right) x_k^{g_k} x_\ell^{g_\ell}$$

$$\stackrel{\text{(B.3a)}}{\approx} \left( \prod_{i \neq k, \ell} x_i^{f_i} \right) x_k^{f_k} x_\ell^{f_\ell} \quad \text{since } g_i \equiv f_i \pmod{n} \text{ and } f_\ell \geq 2$$

$$\stackrel{\text{(B.3c)}}{\approx} \mathbf{v}.$$

(ii) It suffices to show that the identities (B.3b) are deducible from the identities  $\alpha : x^2 y^2 \approx y^2 x^2$  and  $\beta : x y a \approx y x a$ . Write  $m_i = 2p_i + r_i$ , where  $p_i \geq 1$  and  $r_i \in \{0, 1\}$ . Then

$$x^{m_1} y^{m_2} \stackrel{\beta}{\approx} y^{r_2} x^{r_1} x^{2p_1} y^{2p_2} \stackrel{\alpha}{\approx} y^{r_2} x^{r_1} y^{2p_2} x^{2p_1} \stackrel{\beta}{\approx} y^{m_2} x^{m_1}. \quad \square$$

**Proposition B.16** (Petrich [60, Lemma 7.3 and Diagram 8]). *Let  $n \geq 2$  be any integer.*

(i) *The identities*

$$x^{n+1} a \approx x a, \quad x y \approx y x$$

*constitute an identity basis for the variety  $\text{var}\{N_2, Sl_2, \mathbb{Z}_n\}$ .*

(ii) *The identities*

$$x^n a b \approx a b, \quad x y \approx y x$$

*constitute an identity basis for the variety  $\text{var}\{N_2, \mathbb{Z}_n\}$ .*

(iii) *The identities*

$$x^{n+1} \approx x, \quad x y \approx y x$$

*constitute an identity basis for the variety  $\text{var}\{Sl_2, \mathbb{Z}_n\}$ .*

### B.10 Subvarieties of $\mathbf{V}_{23} = \text{var}\{N_4\}$

**Proposition B.17** (Mel'nik [54, Subvarieties of  $B_{23}$  in Figure 3]).

(i) *The proper nontrivial subvarieties of  $\mathbf{V}_{23} = \text{var}\{N_4\}$  are*

$$\begin{aligned} \mathbf{V}_1 &= \text{var}\{N_2\}, & \mathbf{V}_6 &= \text{var}\{N_3\}, & \mathbf{V}_{22} &= \text{var}\{G_4\}, \\ \mathbf{V}_{86} &= \text{var}\left\{ \begin{array}{l} [1111111, 1111111, 1111112, 1111121, 1111122, 1112235, \\ 1121254] \end{array} \right\}, \\ \mathbf{V}_{87} &= \text{var}\left\{ \begin{array}{l} [1111 1111, 1111 1111, 1111 1112, 1111 1121, 1111 1211, \\ 1111 2134, 1112 1315, 1121 1451] \end{array} \right\}, \\ \mathbf{V}_{88} &= \text{var}\left\{ \begin{array}{l} [1111 1111, 1111 1111, 1111 1112, 1111 1121, 1111 1211, \\ 1111 2134, 1112 1315, 1121 1452] \end{array} \right\}. \end{aligned}$$

(ii) *The lattice  $\mathcal{L}(\mathbf{V}_{23})$  is given in Figure 30.*

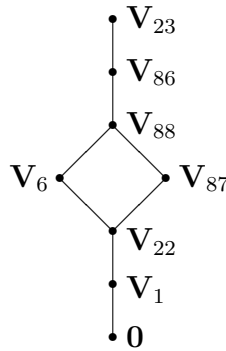

Figure 30: The lattice  $\mathcal{L}(\mathbf{V}_{23})$

## C Some varieties with infinitely many subvarieties

### C.1 The variety $\text{var}\{\mathbb{Z}_p, N_n^1\}$

**Proposition C.1.** *Let  $p \geq 1$  and  $n \geq 2$  be any integers.*

(i) *The identities*

$$x^{n+p} \approx x^n, \tag{C.1a}$$

$$xy \approx yx \tag{C.1b}$$

constitute an identity basis for the variety  $\text{var}\{\mathbb{Z}_p, N_n^1\}$ .

- (ii) *The variety  $\text{var}\{\mathbb{Z}_p, N_n^1\}$  contains countably infinitely many subvarieties.*

*Proof.* (i) It is routinely checked that the identities (C.1) are satisfied by the variety  $\text{var}\{\mathbb{Z}_p, N_n^1\}$ . Hence it remains to show that any identity  $\mathbf{u} \approx \mathbf{v}$  satisfied by  $\text{var}\{\mathbb{Z}_p, N_n^1\}$  is deducible from (C.1). Generality is not lost by assuming that  $\mathbf{u}, \mathbf{v} \in \{x_1, x_2, \dots, x_m\}^*$  with  $e_i = \text{occ}(x_i, \mathbf{u})$  and  $f_i = \text{occ}(x_i, \mathbf{v})$ . Then it follows from Lemma A.1 parts (iv) and (v) that for each  $i$ ,

- (a) either  $e_i = f_i < n$  or  $e_i, f_i \geq n$ ;
- (b)  $e_i \equiv f_i \pmod{p}$ .

If  $e_i \neq f_i$  for some  $i$ , then  $e_i, f_i \in \{n + rp \mid r \geq 0\}$  by (a) and (b), whence the identity  $x^{e_i} \approx x^{f_i}$  is deducible from (C.1a). It follows that

$$\mathbf{u} \stackrel{(C.1b)}{\approx} \prod_{i=1}^m x_i^{e_i} \stackrel{(C.1a)}{\approx} \prod_{i=1}^m x_i^{f_i} \stackrel{(C.1b)}{\approx} \mathbf{v}$$

(ii) Any variety of commutative semigroups is finitely based [59]. Hence by Lemma A.5, the variety  $\text{var}\{\mathbb{Z}_p, N_n^1\}$  contains countably many subvarieties. The result then holds since the subvariety  $\text{var}\{N_2^1\}$  of  $\text{var}\{\mathbb{Z}_p, N_n^1\}$  contains infinitely many subvarieties [13, Figure 5(b)].  $\square$

**Corollary C.2.** *Let  $n \geq 2$  be any integer.*

- (i) *The identities*

$$x^{n+1} \approx x^n, \tag{C.2a}$$

$$xy \approx yx \tag{C.2b}$$

constitute an identity basis for the variety  $\text{var}\{N_n^1\}$ .

- (ii) *The variety  $\text{var}\{N_n^1\}$  contains countably infinitely many subvarieties.*

**Lemma C.3** (Lee *et al.* [45, Proposition 5.10]). *Each proper subvariety of  $\text{var}\{N_n^1\}$  satisfies the identity*

$$x^n y^{n-1} \approx x^{n-1} y^n. \tag{C.3}$$

**Proposition C.4.** *Let  $n \geq 2$  be any integer.*

- (i) *The variety  $\text{var}\{(C.2), (C.3)\}$  is the only maximal subvariety of  $\text{var}\{N_n^1\}$ .*
- (ii) *The variety  $\text{var}\{(C.2), (C.3)\}$  is not finitely generated.*

*Proof.* (i) This follows from Corollary C.2(i) and Lemma C.3.

(ii) It is easily seen that the variety  $\text{var}\{(C.2), (C.3)\}$  violates the identity

$$x_1x_2 \cdots x_my^n \approx x_1x_2 \cdots x_my^{n-1} \quad (C.4)$$

for any  $m \geq 1$ . Hence it suffices to show that each finite semigroup  $S$  in the variety  $\text{var}\{(C.2), (C.3)\}$  satisfies the identity (C.4) for all  $m \geq n|S|$ . Choose any elements  $a_1, a_2, \dots, a_m, b \in S$ . Then the list  $a_1, a_2, \dots, a_m$  contains some element  $a \in S$  at least  $n$  times, due to the magnitude of  $m$ . Therefore  $a_1a_2 \cdots a_m \stackrel{(C.2b)}{=} sa^n$  for some  $s \in S$ , whence

$$\begin{aligned} a_1a_2 \cdots a_mb^n &\stackrel{(C.2b)}{=} sa^n b^n \stackrel{(C.3)}{=} sa^{n+1}b^{n-1} \\ &\stackrel{(C.2a)}{=} sa^n b^{n-1} \stackrel{(C.2b)}{=} a_1a_2 \cdots a_mb^{n-1}. \end{aligned} \quad \square$$

**Lemma C.5.** *Let  $p \geq 2$  be any prime and  $n \geq 2$  be any integer. Then each proper subvariety of  $\text{var}\{\mathbb{Z}_p, N_n^1\}$  satisfies one of the following identities:*

$$x^{n-1+p}y^{n-1} \approx x^{n-1}y^{n-1+p}, \quad (C.5)$$

$$x^{n+1} \approx x^n. \quad (C.6)$$

*Proof.* Let  $\mathbf{W}$  be any proper subvariety of  $\text{var}\{\mathbb{Z}_p, N_n^1\}$ . Then either  $\mathbb{Z}_p \notin \mathbf{W}$  or  $N_n^1 \notin \mathbf{W}$ . First suppose that  $N_n^1 \notin \mathbf{W}$ . Then it follows from Lemma A.2 that the variety  $\mathbf{W}$  satisfies the identity  $\alpha : (x^ny)^{n-1+p}x^n \approx (x^ny)^{n-1}x^n$ . Let  $r \geq 1$  be such that  $n^2 + r \equiv n \pmod{p}$ . Then since

$$\begin{aligned} x^{n-1+p}y^n &\stackrel{(C.1a)}{\approx} x^{n-1+p}y^{n^2+r} = x^{n-1+p}(y^n)^ny^r \\ &\stackrel{(C.1a)}{\approx} x^{n-1+p}(y^n)^{n+p}y^r \stackrel{(C.1b)}{\approx} (y^nx)^{n-1+p}y^ny^r \\ &\stackrel{\alpha}{\approx} (y^nx)^{n-1}y^ny^r \stackrel{(C.1b)}{\approx} x^{n-1}y^{n^2+r} \stackrel{(C.1a)}{\approx} x^{n-1}y^n, \end{aligned}$$

it follows that  $\mathbf{W}$  satisfies the identity  $\beta : x^{n-1+p}y^{n-1+p} \approx x^{n-1}y^{n-1+p}$ . But since

$$\begin{aligned} x^{n-1}y^{n-1+p} &\stackrel{\beta}{\approx} x^{n-1+p}y^{n-1+p} \stackrel{(C.1b)}{\approx} y^{n-1+p}x^{n-1+p} \\ &\stackrel{\beta}{\approx} y^{n-1}x^{n-1+p} \stackrel{(C.1b)}{\approx} x^{n-1+p}y^{n-1}, \end{aligned}$$

the variety  $\mathbf{W}$  also satisfies the identity (C.5).

It remains to assume that  $\mathbb{Z}_p \notin \mathbf{W}$ . Then by Lemma A.1(v), the variety  $\mathbf{W}$  satisfies an identity  $\gamma : \mathbf{u} \approx \mathbf{v}$  with  $\text{occ}(x, \mathbf{u}) \not\equiv \text{occ}(x, \mathbf{v}) \pmod{p}$  for some variable  $x \in \mathcal{X}$ . Generality is not lost with the assumption that  $e \equiv \text{occ}(x, \mathbf{u}) \pmod{p}$  and  $f \equiv \text{occ}(x, \mathbf{v}) \pmod{p}$  with  $0 \leq e < f \leq p - 1$ . Let  $\varphi$  denote the substitution that fixes  $x$  and maps every other variable to  $x^p$ . Then

$$x^{n+e} \stackrel{\text{(C.1b)}}{\approx} (\varphi(\mathbf{u}))x^n \stackrel{\gamma}{\approx} (\varphi(\mathbf{v}))x^n \stackrel{\text{(C.1b)}}{\approx} x^{n+f},$$

so that the variety  $\mathbf{W}$  satisfies the identity  $\delta : x^{n+e} \approx x^{n+f}$ . Since

$$x^n \stackrel{\text{(C.1a)}}{\approx} x^{n+e}x^{p-e} \stackrel{\delta}{\approx} x^{n+f}x^{p-e} \stackrel{\text{(C.1a)}}{\approx} x^{n+f-e},$$

the variety  $\mathbf{W}$  satisfies the identity  $\varepsilon : x^n \approx x^{n+\ell}$  for some  $\ell \geq 1$ . Since  $p$  is prime, there exists some  $m \geq 1$  such that  $m\ell \equiv 1 \pmod{p}$ . Therefore

$$x^n \stackrel{\varepsilon}{\approx} x^{n+\ell} \stackrel{\varepsilon}{\approx} x^{n+2\ell} \stackrel{\varepsilon}{\approx} \dots \stackrel{\varepsilon}{\approx} x^{n+m\ell} \stackrel{\text{(C.1a)}}{\approx} x^{n+1},$$

so that the variety  $\mathbf{W}$  satisfies the identity (C.6). □

**Proposition C.6.** *For any prime  $p \geq 2$  and integer  $n \geq 2$ , let*

$$\mathbf{U} = \text{var}\{(C.1), (C.5)\} \quad \text{and} \quad \mathbf{V} = \text{var}\{(C.1), (C.6)\}.$$

Then

- (i)  $\mathbf{U}$  and  $\mathbf{V}$  are precisely all maximal subvarieties of  $\text{var}\{\mathbb{Z}_p, N_n^1\}$ ;
- (ii)  $\mathbf{U}$  is not finitely generated;
- (iii)  $\mathbf{V} = \text{var}\{N_n^1\}$ .

*Proof.* (i) Since  $\mathbb{Z}_p$  satisfies  $\{(C.1), (C.5)\}$  and violates (C.6), while  $N_n^1$  satisfies  $\{(C.1), (C.6)\}$  and violates (C.5), the varieties  $\mathbf{U}$  and  $\mathbf{V}$  are incomparable. The result then follows from Lemma C.5.

(ii) It is easily seen that the variety  $\mathbf{U}$  violates the identity

$$x^{n-1+p}y_1y_2 \cdots y_m \approx x^{n-1}y_1y_2 \cdots y_m \tag{C.7}$$

for any  $m \geq 1$ . Hence it suffices to show that each finite semigroup  $S$  in  $\mathbf{U}$  satisfies the identity (C.7) for all  $m \geq (n+p)|S|$ . Choose any elements  $a, b_1, b_2, \dots, b_m \in S$ . Then the list  $b_1, b_2, \dots, b_m$  contains some element  $b \in S$

at least  $n + p$  times, due to the magnitude of  $m$ . Therefore  $b_1 b_2 \cdots b_m \stackrel{(C.1b)}{=} b^{n+p} s$  for some  $s \in S$ , whence

$$\begin{aligned} a^{n-1} b_1 b_2 \cdots b_m &\stackrel{(C.1b)}{=} a^{n-1} b^{n+p} s \stackrel{(C.5)}{=} a^{n-1+p} b^n s \\ &\stackrel{(C.1a)}{=} a^{n-1+p} b^{n+p} s \stackrel{(C.1b)}{=} a^{n-1+p} b_1 b_2 \cdots b_m. \end{aligned}$$

(iii) This follows from Corollary C.2(i). □

## C.2 The varieties $\text{var}\{J, N_n^1\}$ and $\text{var}\{\overleftarrow{J}, N_n^1\}$

**Proposition C.7.** *Let  $n \geq 2$  be any integer.*

(i) *The identities*

$$x^{n+1} \approx x^n, \tag{C.8a}$$

$$x^{m_1} y^{m_2} \approx y^{m_2} x^{m_2}, \quad m_1, m_2 \in \{2, 3, 4, \dots\}, \tag{C.8b}$$

$$xya \approx yxa \tag{C.8c}$$

*constitute an identity basis for the variety  $\text{var}\{J, N_n^1\}$ .*

(ii) *The identities*

$$x^{n+1} \approx x^n, \quad x^2 y^2 \approx y^2 x^2, \quad xya \approx yxa$$

*also constitute an identity basis for the variety  $\text{var}\{J, N_n^1\}$ .*

(iii) *The variety  $\text{var}\{J, N_n^1\}$  contains countably infinitely many subvarieties.*

*Proof.* (i) It is routinely checked that the identities (C.8) are satisfied by the variety  $\text{var}\{J, N_n^1\}$ . Hence it remains to show that any identity  $\mathbf{u} \approx \mathbf{v}$  satisfied by  $\text{var}\{J, N_n^1\}$  is deducible from (C.8). By Lemma A.3, generality is not lost by assuming that  $\text{con}(\mathbf{u}) = \text{con}(\mathbf{v}) = \{x_1, x_2, \dots, x_m\}$ , so that  $e_i = \text{occ}(x_i, \mathbf{u}) \geq 1$  and  $f_i = \text{occ}(x_i, \mathbf{v}) \geq 1$ . Further, it follows from Lemma A.1(iv) that

(a) for each  $i$ , either  $e_i = f_i < n$  or  $e_i, f_i \geq n$ .

There are two cases.

CASE 1:  $t(\mathbf{u}) = t(\mathbf{v}) = x_k$ . Then

$$\mathbf{u} \stackrel{(C.8c)}{\approx} \left( \prod_{i \neq k} x_i^{e_i} \right) x_k^{e_k}$$

$$\begin{aligned} & \stackrel{\text{(C.8a)}}{\approx} \left( \prod_{i \neq k} x_i^{f_i} \right) x_k^{f_k} \quad \text{by (a)} \\ & \stackrel{\text{(C.8c)}}{\approx} \mathbf{v}. \end{aligned}$$

CASE 2:  $\mathbf{t}(\mathbf{u}) = x_k$  and  $\mathbf{t}(\mathbf{v}) = x_\ell$  with  $k < \ell$ . Then by (a) and Lemma A.3,

$$(b) \quad e_k, f_k, e_\ell, f_\ell \geq 2.$$

Hence

$$\begin{aligned} \mathbf{u} & \stackrel{\text{(C.8c)}}{\approx} \left( \prod_{i \neq k, \ell} x_i^{e_i} \right) x^{e_\ell} x^{e_k} \\ & \stackrel{\text{(C.8b)}}{\approx} \left( \prod_{i \neq k, \ell} x_i^{e_i} \right) x^{e_k} x^{e_\ell} \quad \text{by (b)} \\ & \stackrel{\text{(C.8a)}}{\approx} \left( \prod_{i \neq k, \ell} x_i^{f_i} \right) x^{f_k} x^{f_\ell} \quad \text{by (a)} \\ & \stackrel{\text{(C.8c)}}{\approx} \mathbf{v}. \end{aligned}$$

(ii) As shown in the proof of Proposition B.15(ii), the identities (C.8b) are deducible from  $x^2y^2 \approx y^2x^2$  and  $xya \approx yxa$ . The result thus follows from part (i).

(iii) Any finitely generated variety that satisfies the identity (C.8c) is finitely based [59]. Hence by Lemma A.5, the variety  $\text{var}\{J, N_n^1\}$  contains countably many subvarieties. The result then holds since the subvariety  $\text{var}\{N_2^1\}$  of  $\text{var}\{J, N_n^1\}$  contains infinitely many subvarieties [13, Figure 5(b)].  $\square$

**Lemma C.8.** *Let  $n \geq 2$  be any integer. Then each proper subvariety of  $\text{var}\{J, N_n^1\}$  satisfies one of the following identities:*

$$x^{n-1}y^n \approx y^{n-1}x^n, \quad (\text{C.9})$$

$$x^n y \approx y x^n. \quad (\text{C.10})$$

*Proof.* Let  $\mathbf{W}$  be any proper subvariety of  $\text{var}\{J, N_n^1\}$ . Then either  $J \notin \mathbf{W}$  or  $N_n^1 \notin \mathbf{W}$ . First suppose that  $N_n^1 \notin \mathbf{W}$ . Then by Lemma A.2, the variety  $\mathbf{W}$  satisfies the identity (A.2) with  $k = 1$ . Since

$$x^{n-1}y^n \stackrel{\text{(C.8)}}{\approx} (y^n x)^{n-1} y^n \stackrel{\text{(A.2)}}{\approx} (y^n x)^n y^n \stackrel{\text{(C.8)}}{\approx} x^n y^n,$$

the variety  $\mathbf{W}$  satisfies the identity  $\alpha : x^{n-1}y^n \approx x^ny^n$ ; since

$$x^{n-1}y^n \stackrel{\alpha}{\approx} x^ny^n \stackrel{(C.8b)}{\approx} y^nx^n \stackrel{\alpha}{\approx} y^{n-1}x^n,$$

it also satisfies the identity (C.9).

It remains to assume that  $J \notin \mathbf{W}$ , so that by Lemma A.4, the variety  $\mathbf{W}$  satisfies one of the identities (A.4) and (A.5). Since

$$\begin{aligned} x^ny &\stackrel{(A.4)}{\approx} (x^ny)^{n+1} \stackrel{(C.8)}{\approx} (x^ny)^{n+1}x^n \stackrel{(A.4)}{\approx} x^nyx^n \stackrel{(C.8)}{\approx} yx^n \\ \text{and } x^ny &\stackrel{(A.5)}{\approx} x^nyx^n \stackrel{(C.8)}{\approx} yx^n, \end{aligned}$$

the variety  $\mathbf{W}$  also satisfies the identity (C.10). □

**Proposition C.9.** *For any integer  $n \geq 2$ , let*

$$\mathbf{U} = \text{var}\{(C.8), (C.9)\} \quad \text{and} \quad \mathbf{V} = \text{var}\{(C.8), (C.10)\}.$$

*Then*

- (i)  $\mathbf{U}$  and  $\mathbf{V}$  are precisely all maximal subvarieties of  $\text{var}\{J, N_n^1\}$ ;
- (ii)  $\mathbf{U}$  is not finitely generated;
- (iii)  $\mathbf{V}$  is not finitely generated.

*Proof.* (i) Since the semigroup  $J$  satisfies  $\{(C.8), (C.9)\}$  and violates (C.10), while the semigroup  $N_n^1$  satisfies  $\{(C.8), (C.10)\}$  and violates (C.9), the varieties  $\mathbf{U}$  and  $\mathbf{V}$  are incomparable. The result then follows from Lemma C.8.

(ii) It is easily seen that the variety  $\mathbf{U}$  violates the identity

$$x^ny_1y_2 \cdots y_m \approx x^{n-1}y_1y_2 \cdots y_m \tag{C.11}$$

for any  $m \geq 1$ . Hence it suffices to show that each finite semigroup  $S$  in  $\mathbf{U}$  satisfies the identity (C.11) for all  $m \geq (n+1)|S|$ . Choose any  $a, b_1, b_2, \dots, b_m \in S$ . Then the list  $b_1, b_2, \dots, b_m$  contains some element  $b \in S$  at least  $n+1$  times, due to the magnitude of  $m$ . Therefore  $b_1b_2 \cdots b_m \stackrel{(C.8c)}{=} b^n s b t$  for some  $s, t \in S^1$ , whence

$$\begin{aligned} a^{n-1}b_1b_2 \cdots b_m &\stackrel{(C.8c)}{=} a^{n-1}b^n s b t \stackrel{(C.8a)}{=} a^{n-1}b^n b s b t \stackrel{(C.9)}{=} b^{n-1}a^n b s b t \\ &\stackrel{(C.8c)}{=} a^n b^n s b t \stackrel{(C.8c)}{=} a^n b_1 b_2 \cdots b_m. \end{aligned}$$

(iii) It is easily seen that the variety  $\mathbf{V}$  violates the identity

$$x_1x_2 \cdots x_my z \approx x_1x_2 \cdots x_mz y \tag{C.12}$$

for any  $m \geq 1$ . Hence it suffices to show that each finite semigroup  $S$  in  $\mathbf{V}$  satisfies the identity (C.12) for all  $m \geq n|S|$ . Choose any elements  $a_1, a_2, \dots, a_m, b, c \in S$ . Then the list  $a_1, a_2, \dots, a_m$  contains some element  $a \in S$  at least  $n$  times, due to the magnitude of  $m$ . Thus  $a_1 a_2 \cdots a_m b \stackrel{(C.8c)}{=} sa^n b$  and  $a_1 a_2 \cdots a_m c \stackrel{(C.8c)}{=} sa^n c$  for some  $s \in S$ , whence

$$\begin{aligned} a_1 a_2 \cdots a_m b c &\stackrel{(C.8c)}{=} sa^n b c \stackrel{(C.10)}{=} sbca^n \stackrel{(C.8c)}{=} scba^n \\ &\stackrel{(C.10)}{=} sa^n cb \stackrel{(C.8c)}{=} a_1 a_2 \cdots a_m cb. \end{aligned} \quad \square$$

**Corollary C.10.** *Let  $n \geq 2$  be any integer. Then*

(i) *the identities*

$$x^{n+1} \approx x^n, \quad x^2 y^2 \approx y^2 x^2, \quad axy \approx ayx$$

*constitute an identity basis for the variety  $\text{var}\{\overleftarrow{J}, N_n^1\}$ ;*

(ii)  *$\text{var}\{\overleftarrow{J}, N_n^1\}$  contains countably infinitely many subvarieties;*

(iii)  *$\text{var}\{\overleftarrow{J}, N_n^1\}$  contains precisely two maximal subvarieties.*

### C.3 The varieties $\text{var}\{LZ_2, N_n^1\}$ and $\text{var}\{RZ_2, N_n^1\}$

**Proposition C.11.** *Let  $n \geq 2$  be any integer.*

(i) *The identities*

$$x^{n+1} \approx x^n, \tag{C.13a}$$

$$axy \approx ayx. \tag{C.13b}$$

*constitute an identity basis for the variety  $\text{var}\{LZ_2, N_n^1\}$ .*

(ii) *The variety  $\text{var}\{LZ_2, N_n^1\}$  contains countably infinitely many subvarieties.*

*Proof.* (i) It is routinely checked that the identities (C.13) are satisfied by the variety  $\text{var}\{LZ_2, N_n^1\}$ . Therefore it remains to show that any identity  $\mathbf{u} \approx \mathbf{v}$  satisfied by  $\text{var}\{LZ_2, N_n^1\}$  is deducible from the identities (C.13). Generality is not lost by assuming that  $\mathbf{u}, \mathbf{v} \in \{x_1, x_2, \dots, x_m\}^*$  with  $e_i = \text{occ}(x_i, \mathbf{u})$  and  $f_i = \text{occ}(x_i, \mathbf{v})$ . By Lemma A.1 parts (i) and (iv),

(a)  $\mathbf{h}(\mathbf{u}) = \mathbf{h}(\mathbf{v}) = x_k$  for some  $k$ ;

(b) for each  $i$ , either  $e_i = f_i < n$  or  $e_i, f_i \geq n$ .

Hence

$$\begin{aligned} \mathbf{u} &\stackrel{\text{(C.13b)}}{\approx} x_k^{e_k} \prod_{i \neq k} x_i^{e_i} \\ &\stackrel{\text{(C.13a)}}{\approx} x_k^{f_k} \prod_{i \neq k} x_i^{f_i} \quad \text{by (b)} \\ &\stackrel{\text{(C.13b)}}{\approx} \mathbf{v}. \end{aligned}$$

(ii) See the proof of Proposition C.7(iii). □

**Lemma C.12.** *Let  $n \geq 2$  be any integer. Then each proper subvariety of the variety  $\text{var}\{LZ_2, N_n^1\}$  satisfies one of the following identities:*

$$x^n y^n \approx y^n x^n, \tag{C.14}$$

$$a^n x^n \approx a^n x^{n-1}. \tag{C.15}$$

*Proof.* Let  $\mathbf{W}$  be any proper subvariety of  $\text{var}\{LZ_2, N_n^1\}$ . Then either  $LZ_2 \notin \mathbf{W}$  or  $N_n^1 \notin \mathbf{W}$ . First suppose that  $LZ_2 \notin \mathbf{W}$ . Then the variety  $\mathbf{W}$  satisfies the identity  $\alpha : x^n (yx^n)^n \approx (yx^n)^n$  [45, Theorem 5.15]. Since

$$x^n y^n \stackrel{\text{(C.13)}}{\approx} x^n (yx^n)^n \stackrel{\alpha}{\approx} (yx^n)^n \stackrel{\text{(C.13)}}{\approx} y^n x^n,$$

the variety  $\mathbf{W}$  satisfies the identity (C.14).

It remains to assume that  $N_n^1 \notin \mathbf{W}$ . Then by Lemma A.2, the variety  $\mathbf{W}$  satisfies the identity (A.2) with  $k = 1$ . Since

$$a^n x^n \stackrel{\text{(C.13)}}{\approx} (a^n x)^n a^n \stackrel{\text{(A.2)}}{\approx} (a^n x)^{n-1} a^n \stackrel{\text{(C.13)}}{\approx} a^n x^{n-1},$$

the variety  $\mathbf{W}$  satisfies the identity (C.15). □

**Proposition C.13.** *For any integer  $n \geq 2$ , let*

$$\mathbf{U} = \text{var}\{(C.13), (C.14)\} \quad \text{and} \quad \mathbf{V} = \text{var}\{(C.13), (C.15)\}.$$

*Then*

- (i)  $\mathbf{U}$  and  $\mathbf{V}$  are the only maximal subvarieties of  $\text{var}\{LZ_2, N_n^1\}$ ;
- (ii)  $\mathbf{U} = \text{var}\{\overleftarrow{J}, N_2^1\}$  if  $n = 2$ ;
- (iii)  $\mathbf{V}$  is not finitely generated.

*Proof.* (i) Since the semigroup  $LZ_2$  satisfies  $\{(C.13), (C.15)\}$  and violates (C.14), while the semigroup  $N_n^1$  satisfies  $\{(C.13), (C.14)\}$  and violates (C.15), the varieties  $\mathbf{U}$  and  $\mathbf{V}$  are incomparable. The result then follows from Lemma C.12.

(ii) This follows from the dual of Proposition C.7(ii).

(iii) It is easily seen that the variety  $\mathbf{V}$  violates the identity

$$x_1x_2 \cdots x_my^n \approx x_1x_2 \cdots x_my^{n-1} \tag{C.16}$$

for any  $m \geq 1$ . Hence it suffices to show that each finite semigroup  $S$  in  $\mathbf{V}$  satisfies the identity (C.16) for all  $m \geq (n+1)|S|$ . Choose any  $a_1, a_2, \dots, a_m, b \in S$ . Then the list  $a_1, a_2, \dots, a_m$  contains some element  $a \in S$  at least  $n+1$  times, due to the magnitude of  $m$ . Therefore  $a_1a_2 \cdots a_m \stackrel{(C.13b)}{=} sata^n$  for some  $s, t \in S^1$ , whence

$$a_1a_2 \cdots a_mb^n \stackrel{(C.13b)}{=} sata^nb^n \stackrel{(C.15)}{=} sata^nb^{n-1} \stackrel{(C.13b)}{=} a_1a_2 \cdots a_mb^{n-1}. \quad \square$$

**Corollary C.14.** *Let  $n \geq 2$  be any integer. Then*

(i) *the identities*

$$x^{n+1} \approx x^n, \quad xya \approx yxa$$

*constitute an identity basis for the variety  $\text{var}\{RZ_2, N_n^1\}$ ;*

(ii)  *$\text{var}\{RZ_2, N_n^1\}$  contains countably infinitely many subvarieties;*

(iii)  *$\text{var}\{RZ_2, N_n^1\}$  contains precisely two maximal subvarieties.*

#### C.4 The varieties $\text{var}\{LZ_2^1, N_n^1\}$ and $\text{var}\{RZ_2^1, N_n^1\}$

**Proposition C.15.** *Let  $n \geq 2$  be any integer.*

(i) *The identities*

$$x^{n+1} \approx x^n, \tag{C.17a}$$

$$xyx \approx x^2y. \tag{C.17b}$$

*constitute an identity basis for the variety  $\text{var}\{LZ_2^1, N_n^1\}$ .*

(ii) *The variety  $\text{var}\{LZ_2^1, N_n^1\}$  contains countably infinitely many subvarieties.*

*Proof.* (i) It is routinely checked that the identities (C.17) are satisfied by the variety  $\text{var}\{LZ_2^1, N_n^1\}$ . Therefore it remains to show that any identity  $\mathbf{u} \approx \mathbf{v}$  satisfied by  $\text{var}\{LZ_2^1, N_n^1\}$  is deducible from the identities (C.17). In view of Lemma A.1(ii), generality is not lost by assuming that

$$(a) \text{ ini}(\mathbf{u}) = \text{ini}(\mathbf{v}) = \prod_{i=1}^m x_i,$$

so that  $e_i = \text{occ}(x_i, \mathbf{u}) \geq 1$  and  $f_i = \text{occ}(x_i, \mathbf{v}) \geq 1$ . By Lemma A.1(iv),

$$(b) \text{ for each } i, \text{ either } e_i = f_i < n \text{ or } e_i, f_i \geq n.$$

Hence

$$\begin{aligned} \mathbf{u} &\stackrel{(C.17b)}{\approx} \prod_{i=1}^m x_i^{e_i} \quad \text{by (a)} \\ &\stackrel{(C.17a)}{\approx} \prod_{i=1}^m x_i^{f_i} \quad \text{by (b)} \\ &\stackrel{(C.17b)}{\approx} \mathbf{v} \quad \text{by (a)}. \end{aligned}$$

(ii) Any variety that satisfies the identity (C.17b) is finitely based [61]. Hence by Lemma A.5, the variety  $\text{var}\{LZ_2^1, N_n^1\}$  contains countably many subvarieties. The result then holds since the subvariety  $\text{var}\{N_2^1\}$  of  $\text{var}\{LZ_2^1, N_n^1\}$  contains infinitely many subvarieties [13, Figure 5(b)].  $\square$

**Lemma C.16.** *Let  $n \geq 2$  be any integer. Then each proper subvariety of the variety  $\text{var}\{LZ_2^1, N_n^1\}$  satisfies one of the following identities:*

$$a^n x^n y^n \approx a^n y^n x^n, \tag{C.18}$$

$$a^n x^n \approx a^n x^{n-1}. \tag{C.19}$$

*Proof.* Let  $\mathbf{W}$  be any proper subvariety of  $\text{var}\{LZ_2^1, N_n^1\}$ . Then either  $LZ_2^1 \notin \mathbf{W}$  or  $N_n^1 \notin \mathbf{W}$ . First suppose that  $LZ_2^1 \notin \mathbf{W}$ . Then the variety  $\mathbf{W}$  satisfies the identity  $\alpha : a^n(xa^n)^n(ya^n(xa^n)^n)^n \approx a^n(ya^n(xa^n)^n)^n$  [45, Theorem 5.17]. Since

$$a^n x^n y^n \stackrel{(C.17)}{\approx} a^n(xa^n)^n(ya^n(xa^n)^n)^n \stackrel{\alpha}{\approx} a^n(ya^n(xa^n)^n)^n \stackrel{(C.17)}{\approx} a^n y^n x^n,$$

the variety  $\mathbf{W}$  satisfies the identity (C.18).

It remains to assume that  $N_n^1 \notin \mathbf{W}$ . Then by Lemma A.2, the variety  $\mathbf{W}$  satisfies the identity (A.2) with  $k = 1$ . Since

$$a^n x^n \stackrel{(C.17)}{\approx} (a^n x)^n a^n \stackrel{(A.2)}{\approx} (a^n x)^{n-1} a^n \stackrel{(C.17)}{\approx} a^n x^{n-1},$$

the variety  $\mathbf{W}$  satisfies the identity (C.19).  $\square$

**Proposition C.17.** *For any integer  $n \geq 2$ , let*

$$\mathbf{U} = \text{var}\{(C.17), (C.18)\} \quad \text{and} \quad \mathbf{V} = \text{var}\{(C.17), (C.19)\}.$$

*Then*

- (i)  $\mathbf{U}$  and  $\mathbf{V}$  are the only maximal subvarieties of  $\text{var}\{LZ_2^1, N_n^1\}$ ;
- (ii)  $\mathbf{U}$  is not finitely generated;
- (iii)  $\mathbf{V}$  is not finitely generated.

*Proof.* (i) Since the semigroup  $LZ_2^1$  satisfies  $\{(C.17), (C.19)\}$  and violates (C.18), while the semigroup  $N_n^1$  satisfies  $\{(C.17), (C.18)\}$  and violates (C.19), the varieties  $\mathbf{U}$  and  $\mathbf{V}$  are incomparable. The result then follows from Lemma C.16.

(ii) It is easily seen that the variety  $\mathbf{U}$  violates the identity

$$x_1x_2 \cdots x_my^n z^n \approx x_1x_2 \cdots x_mz^n y^n \quad (C.20)$$

for any  $m \geq 1$ . Hence it suffices to show that each finite semigroup  $S$  in the variety  $\mathbf{U}$  satisfies the identity (C.20) for all  $m \geq n|S|$ . Choose any elements  $a_1, a_2, \dots, a_m, b, c \in S$ . Then the list  $a_1, a_2, \dots, a_m$  contains some element  $a \in S$  at least  $n$  times, due to the magnitude of  $m$ . Therefore  $a_1a_2 \cdots a_m \stackrel{(C.17b)}{=} sa^nt$  for some  $s, t \in S^1$ , whence

$$\begin{aligned} a_1a_2 \cdots a_mb^nc^n &\stackrel{(C.17b)}{=} sa^ntb^nc^n \stackrel{(C.17)}{=} sa^nta^n b^nc^n \stackrel{(C.18)}{=} sa^nta^nc^nb^n \\ &\stackrel{(C.17)}{=} sa^ntc^nb^n \stackrel{(C.17b)}{=} a_1a_2 \cdots a_m c^nb^n. \end{aligned}$$

(iii) It is easily seen that the variety  $\mathbf{V}$  violates the identity

$$x_1x_2 \cdots x_my^n \approx x_1x_2 \cdots x_my^{n-1} \quad (C.21)$$

for any  $m \geq 1$ . Hence it suffices to show that each finite semigroup  $S$  in the variety  $\mathbf{V}$  satisfies the identity (C.21) for all  $m \geq n|S|$ . Choose any elements  $a_1, a_2, \dots, a_m, b \in S$ . Then the list  $a_1, a_2, \dots, a_m$  contains some element  $a \in S$  at least  $n$  times, due to the magnitude of  $m$ . Therefore  $a_1a_2 \cdots a_m \stackrel{(C.17b)}{=} sa^nt$  for some  $s, t \in S^1$ , whence

$$\begin{aligned} a_1a_2 \cdots a_mb^n &\stackrel{(C.17b)}{=} sa^ntb^n \stackrel{(C.17)}{=} sa^nta^nb^n \stackrel{(C.19)}{=} sa^nta^nb^{n-1} \\ &\stackrel{(C.17)}{=} sa^ntb^{n-1} \stackrel{(C.17b)}{=} a_1a_2 \cdots a_m b^{n-1}. \quad \square \end{aligned}$$

**Corollary C.18.** *Let  $n \geq 2$  be any integer. Then*

(i) *the identities*

$$x^{n+1} \approx x^n, \quad xyx \approx yx^2$$

*constitute an identity basis for the variety  $\text{var}\{RZ_2^1, N_n^1\}$ ;*

(ii)  *$\text{var}\{RZ_2^1, N_n^1\}$  contains countably infinitely many subvarieties;*

(iii)  *$\text{var}\{RZ_2^1, N_n^1\}$  contains precisely two maximal subvarieties.*

**C.5 The varieties  $V_{38} = \text{var}\{B_0\}$  and  $V_{39} = \text{var}\{A_0\}$**

**Proposition C.19** (Edmunds [11, Semigroups  $S(4, 21)$  and  $S(4, 22)$  on page 70]; Lee [30]).

(i) *The identities*

$$x^3 \approx x^2, \quad x^2yx^2 \approx yxy, \quad x^2y^2 \approx y^2x^2$$

*constitute an identity basis for the variety  $V_{38} = \text{var}\{B_0\}$ .*

(ii) *The identities*

$$x^3 \approx x^2, \quad x^2yx^2 \approx yxy$$

*constitute an identity basis for the variety  $V_{39} = \text{var}\{A_0\}$ .*

(iii) *The varieties  $\text{var}\{B_0\}$  and  $\text{var}\{A_0\}$  each contains countably infinitely many subvarieties.*

**Proposition C.20** (Lee [30, 31]).

(i) *The variety  $\text{var}\{B_0\}$  is the unique maximal subvariety of  $\text{var}\{A_0\}$ .*

(ii) *The identities*

$$x^3 \approx x^2, \quad x^2yx^2 \approx yxy, \quad x^2y^2 \approx y^2x^2, \quad a^2x^2b^2 \approx a^2xb^2. \quad (\text{C.22})$$

*constitute an identity basis for the unique maximal subvariety of  $\text{var}\{B_0\}$ .*

(iii) *The unique maximal subvariety of  $\text{var}\{B_0\}$  is not finitely generated.*

**C.6 The varieties  $V_{40} = \text{var}\{J^1\}$  and  $V_{46} = \text{var}\{\overleftarrow{J^1}\}$**

**Proposition C.21.**

(i) *The identities*

$$x^3 \approx x^2, \quad (\text{C.23a})$$

$$x^2y^2 \approx y^2x^2, \quad (\text{C.23b})$$

$$xyx \approx yx^2. \quad (\text{C.23c})$$

*constitute an identity basis for the variety  $\text{var}\{J^1\}$ .*

(ii) *The variety  $\text{var}\{J^1\}$  contains countably infinitely many subvarieties.*

*Proof.* (i) See Edmunds [11, Semigroup  $\mathbf{S}(4, 23)$  on page 70].

(ii) Any variety that satisfies the identity (C.23c) is finitely based [61]. Hence by Lemma A.5, the variety  $\text{var}\{J^1\}$  contains countably many subvarieties. The result then holds since the subvariety  $\text{var}\{N_2^1\}$  of  $\text{var}\{J^1\}$  contains infinitely many subvarieties [13, Figure 5(b)].  $\square$

**Lemma C.22.** *Each proper subvariety of  $\text{var}\{J^1\}$  satisfies the identity*

$$x^2ya^2 \approx yx^2a^2. \quad (\text{C.24})$$

*Proof.* Let  $\mathbf{W}$  be any proper subvariety of  $\text{var}\{J^1\}$ , so that  $J^1 \notin \mathbf{W}$ . Then it follows from Almeida [1, Proposition 11.7.9] that  $\mathbf{W}$  satisfies either (C.24) or  $\alpha : x^2y^2 \approx xy^2$ . Since

$$x^2ya^2 \stackrel{\alpha}{\approx} x^2y^2a^2 \stackrel{(\text{C.23b})}{\approx} y^2x^2a^2 \stackrel{\alpha}{\approx} yx^2a^2,$$

the variety  $\mathbf{W}$  always satisfies the identity (C.24).  $\square$

**Proposition C.23.** *Let  $\mathbf{U} = \text{var}\{(\text{C.23}), (\text{C.24})\}$ . Then*

- (i)  $\mathbf{U}$  is the unique maximal subvariety of  $\mathbf{V}_{40} = \text{var}\{J^1\}$ ;
- (ii)  $\mathbf{U}$  is not finitely generated.

*Proof.* (i) This follows from Proposition C.21(i) and Lemma C.22.

(ii) It is easily seen that the variety  $\mathbf{U}$  violates the identity

$$x^2yz_1z_2 \cdots z_m \approx yx^2z_1z_2 \cdots z_m \quad (\text{C.25})$$

for any  $m \geq 1$ . Hence it suffices to show that each finite semigroup  $S$  in  $\mathbf{U}$  satisfies the identity (C.25) for all  $m > |S|$ . Choose any elements  $a, b, c_1, c_2, \dots, c_m \in S$ . The list  $c_1, c_2, \dots, c_m$  contains some element  $c \in S$  twice, due to the magnitude of  $m$ . Therefore  $c_1c_2 \cdots c_m = s_1cs_2cs_3$  for some  $s_i \in S^1$ , whence

$$\begin{aligned} a^2bc_1c_2 \cdots c_m &= a^2bs_1cs_2cs_3 \stackrel{(\text{C.23})}{=} a^2bc^2s_1cs_2cs_3 \stackrel{(\text{C.24})}{=} ba^2c^2s_1cs_2cs_3 \\ &\stackrel{(\text{C.23})}{=} ba^2s_1cs_2cs_3 = ba^2c_1c_2 \cdots c_m. \end{aligned} \quad \square$$

**Corollary C.24.**

- (i) *The identities*

$$x^3 \approx x^2, \quad x^2y^2 \approx y^2x^2, \quad xyx \approx x^2y.$$

*constitute an identity basis for the variety  $\mathbf{V}_{46} = \text{var}\{\overleftarrow{J^1}\}$ .*

- (ii) *The variety  $\text{var}\{\overleftarrow{J^1}\}$  contains countably infinitely many subvarieties.*
- (iii) *The variety  $\text{var}\{\overleftarrow{J^1}\}$  contains a unique maximal subvariety.*

## References

- [1] J. Almeida, *Finite Semigroups and Universal Algebra*, World Scientific, Singapore, 1994.
- [2] J. Araújo, J. P. Araújo, P. J. Cameron, E. W. H. Lee, and J. Raminhos, [sgv.pythonanywhere.com](http://sgv.pythonanywhere.com)
- [3] A. P. Birjukov, Varieties of idempotent semigroups, *Algebra and Logic* **9** (1970), no. 3, 153–164; translation of *Algebra i Logika* **9** (1970), no. 3, 255–273.
- [4] G. Birkhoff, *Lattice Theory*, Amer. Math. Soc, Coll. Publ. Vol. 25, (3rd. edition, 3rd printing), Providence, RI, 1979.
- [5] S. M. Bogdanović, M. D. Ćirić, and Z. L. Popović, *Semilattice Decompositions of Semigroups*, Faculty of Economics, University of Niš, 2011.
- [6] S. Bogdanović and M. Ćirić, Orthogonal sums of semigroups, *Israel J. Math.* **90** (1995), no. 1–3, 423–428.
- [7] S. Burris and H. P. Sankappanavar, *A Course in Universal Algebra*, Springer Verlag, New York, 1981.
- [8] J. Cossey and S. O. Macdonald, A basis for the laws of  $\text{PSL}(2, 5)$ , *Bull. Amer. Math. Soc.* **74** (1968), no. 3, 602–606.
- [9] J. Cossey, S. O. Macdonald, and A. P. Street, On the laws of certain finite groups, *J. Austral. Math. Soc.* **11** (1970), no. 4, 441–489.
- [10] C. C. Edmunds, On certain finitely based varieties of semigroups, *Semigroup Forum* **15** (1977), no. 1, 21–39.
- [11] C. C. Edmunds, Varieties generated by semigroups of order four, *Semigroup Forum* **21** (1980), no. 1, 67–81.
- [12] C. C. Edmunds, E. W. H. Lee, and K. W. K. Lee, Small semigroups generating varieties with continuum many subvarieties, *Order* **27** (2010), no. 1, 83–100.
- [13] T. Evans, The lattice of semigroup varieties, *Semigroup Forum* **2** (1971), no. 1, 1–43.
- [14] C. F. Fennemore, All varieties of bands. I, II, *Math. Nachr.* **48** (1971), no. 1–6, 237–252; *ibid.* **48** (1971), no. 1–6, 253–262.

- [15] J. A. Gerhard, The lattice of equational classes of idempotent semigroups, *J. Algebra* **15** (1970), no. 2, 195–224.
- [16] J. A. Gerhard and M. Petrich, All varieties of regular orthogroups, *Semigroup Forum* **31** (1985), no. 3, 311–351.
- [17] J. A. Gerhard and M. Petrich, Varieties of bands revisited, *Proc. London Math. Soc. (3)* **58** (1989), no. 2, 323–350.
- [18] È. A. Golubov and M. V. Sapir, Varieties of finitely approximable semigroups, *Soviet Math. (Iz. VUZ)* **26** (1982), no. 11, 25–36; translation of *Izv. Vyssh. Uchebn. Zaved. Mat.* 1982, no. 11, 21–29.
- [19] G. Higman, Some remarks on varieties of groups, *Quart. J. Math. Oxford (2)* **10** (1959), no. 1, 165–178.
- [20] J. M. Howie, *Fundamentals of Semigroup Theory*, Oxford University Press, New York, 1995.
- [21] S. V. Ivanov and A. M. Storozhev, On varieties of groups in which all periodic groups are abelian, *Group theory, statistics, and cryptography*, 55–62, *Contemp. Math.* **360**, Amer. Math. Soc., Providence, RI, 2004.
- [22] M. Jackson, Finite semigroups whose varieties have uncountably many subvarieties, *J. Algebra* **228** (2000), no. 2, 512–535.
- [23] M. Jackson, Small inherently nonfinitely based finite semigroups, *Semigroup Forum* **64** (2002), no. 2, 297–324.
- [24] M. Jackson, Finite semigroups with infinite irredundant identity bases, *Internat. J. Algebra Comput.* **15** (2005), no. 3, 405–422.
- [25] M. Jackson, Syntactic semigroups and the finite basis problem, in V. B. Kudryavtsev *et al.* (eds.), *Structural Theory of Automata, Semigroups, and Universal Algebra*, 159–167, NATO Sci. Ser. II Math. Phys. Chem., 207, Springer, Dordrecht, 2005.
- [26] C. O. Kiselman, A semigroup of operators in convexity theory, *Trans. Amer. Math. Soc.* **354** (2002), no. 5, 2035–2053.
- [27] L. G. Kovács, Free groups in a dihedral variety, *Proc. Roy. Irish Acad. Sect. A* **89** (1989), no. 1, 115–117.
- [28] L. G. Kovács and M. F. Newman, Cross varieties of groups, *Proc. Roy. Soc. Ser. A* **292** (1966), 530–536.

- [29] P. A. Kozhevnikov, On nonfinitely based varieties of groups of large prime exponent, *Comm. Algebra* **40** (2012), no. 7, 2628–2644.
- [30] E. W. H. Lee, Identity bases for some non-exact varieties, *Semigroup Forum* **68** (2004), no. 3, 445–457.
- [31] E. W. H. Lee, Subvarieties of the variety generated by the five-element Brandt semigroup, *Internat. J. Algebra Comput.* **16** (2006), no. 2, 417–441.
- [32] E. W. H. Lee, Minimal semigroups generating varieties with complex subvariety lattices, *Internat. J. Algebra Comput.* **17** (2007), no. 8, 1553–1572.
- [33] E. W. H. Lee, On the complete join of permutative combinatorial Rees–Sushkevich varieties, *Int. J. Algebra* **1** (2007), no. 1–4, 1–9.
- [34] E. W. H. Lee, Combinatorial Rees–Sushkevich varieties are finitely based, *Internat. J. Algebra Comput.* **18** (2008), no. 5, 957–978.
- [35] E. W. H. Lee, On the variety generated by some monoid of order five, *Acta Sci. Math. (Szeged)* **74** (2008), no. 3–4, 509–537.
- [36] E. W. H. Lee, Hereditarily finitely based monoids of extensive transformations, *Algebra Universalis* **61** (2009), no. 1, 31–58.
- [37] E. W. H. Lee, Combinatorial Rees–Sushkevich varieties that are Cross, finitely generated, or small, *Bull. Aust. Math. Soc.* **81** (2010), no. 1, 64–84.
- [38] E. W. H. Lee, Finite basis problem for 2-testable monoids, *Cent. Eur. J. Math.* **9** (2011), no. 1, 1–22.
- [39] E. W. H. Lee, Varieties generated by 2-testable monoids, *Studia Sci. Math. Hungar.* **49** (2012), no. 3, 366–389.
- [40] E. W. H. Lee, Finite basis problem for semigroups of order five or less: generalization and revisitation, *Studia Logica* **101** (2013), no. 1, 95–115.
- [41] E. W. H. Lee, A class of finite semigroups without irredundant bases of identities, *Yokohama Math. J.* **61** (2015), 1–28.
- [42] E. W. H. Lee, Variety membership problem for two classes of non-finitely based semigroups, *Wuhan Univ. J. Nat. Sci.* **23** (2018), no. 4, 323–327.

- [43] E. W. H. Lee and J. R. Li, Minimal non-finitely based monoids, *Dissertationes Math. (Rozprawy Mat.)* **475** (2011), 65 pp.
- [44] E. W. H. Lee, J. R. Li, and W. T. Zhang, Minimal non-finitely based semigroups, *Semigroup Forum* **85** (2012), no. 3, 577–580.
- [45] E. W. H. Lee, J. Rhodes, and B. Steinberg, Join irreducible semigroups, *Internat. J. Algebra Comput.* **29** (2019), no. 7, 1249–1310.
- [46] E. W. H. Lee and M. V. Volkov, On the structure of the lattice of combinatorial Rees–Sushkevich varieties, in J. M. André *et al.* (eds.), *Semigroups and Formal Languages*, 164–187, World Scientific, 2007.
- [47] E. W. H. Lee and M. V. Volkov, Limit varieties generated by completely 0-simple semigroups, *Internat. J. Algebra Comput.* **21** (2011), no. 1–2, 257–294.
- [48] E. W. H. Lee and W. T. Zhang, Finite basis problem for semigroups of order six, *LMS J. Comput. Math.* **18** (2015), no. 1, 1–129.
- [49] Y. F. Luo and W. T. Zhang, On the variety generated by all semigroups of order three, *J. Algebra* **334** (2011), 1–30.
- [50] E. S. Lyapin, *Semigroups*, Translations of Mathematical Monographs, Vol. 3, American Mathematical Society, Providence, RI, 1974.
- [51] S. A. Malyshev, Permutational varieties of semigroups whose lattice of subvarieties is finite (in Russian), in *Modern Algebra*, 71–76, Leningrad. Univ., Leningrad, 1981.
- [52] R. McKenzie, Tarski’s finite basis problem is undecidable, *Internat. J. Algebra Comput.* **6** (1996), no. 1, 49–104.
- [53] R. N. McKenzie, G. F. McNulty, and W. F. Taylor, *Algebras, Lattices, Varieties. I*, Wadsworth and Brooks/Cole, Monterey, CA, 1987.
- [54] I. I. Mel’nik, A description of certain lattices of varieties of semigroups (in Russian), *Izv. Vyssh. Uchebn. Zaved. Mat.* 1972, no. 7, 65–74.
- [55] V. H. Mikaelian, Metabelian varieties of groups and wreath products of abelian groups, *J. Algebra* **313** (2007), no. 2, 455–485.
- [56] B. H. Neumann, Identical relations in groups. I, *Math. Ann.* **114** (1937), no. 1. 506–525.

- [57] H. Neumann, *Varieties of Groups*, Springer, New York, 1967.
- [58] S. Oates and M. B. Powell, Identical relations in finite groups, *J. Algebra* **1** (1964), no. 1, 11–39.
- [59] P. Perkins, Bases for equational theories of semigroups, *J. Algebra* **11** (1969), no. 2, 298–314.
- [60] M. Petrich, All subvarieties of a certain variety of semigroups, *Semigroup Forum* **7** (1974), no. 1–4, 104–152.
- [61] G. Pollák, On two classes of hereditarily finitely based semigroup identities, *Semigroup Forum* **25** (1982), no. 1–2, 9–33.
- [62] M. Petrich and N. R. Reilly, *Completely Regular Semigroups*, Wiley & Sons, New York, 1999.
- [63] M. V. Sapir, Inherently non-finitely based finite semigroups, *Math. USSR-Sb.* **61** (1988), no. 1, 155–166; translation of *Mat. Sb. (N.S.)* **133** (1987), no. 2, 154–166.
- [64] M. V. Sapir, Problems of Burnside type and the finite basis property in varieties of semigroups, *Math. USSR-Izv.* **30** (1988), no. 2, 295–314; translation of *Izv. Akad. Nauk SSSR Ser. Mat.* **51** (1987), no. 2, 319–340.
- [65] M. V. Sapir, On Cross semigroup varieties and related questions, *Semigroup Forum* **42** (1991), no. 3, 345–364.
- [66] M. V. Sapir, *Combinatorial Algebra: Syntax and Semantics*, Springer Monographs in Mathematics, Springer, Cham, 2014.
- [67] M. V. Sapir and E. V. Suhanov, Varieties of periodic semigroups (in Russian), *Izv. Vyssh. Uchebn. Zaved. Mat.* 1981, no. 4, 48–55.
- [68] L. N. Shevrin, Semigroups with certain types of subsemigroup lattices (in Russian), *Dokl. Akad. Nauk SSSR* **138** (1961), no. 4, 796–798.
- [69] L. N. Shevrin, Epigroups, in V. B. Kudryavtsev *et al.* (eds.), *Structural Theory of Automata, Semigroups, and Universal Algebra*, 331–380, NATO Sci. Ser. II Math. Phys. Chem., 207, Springer, Dordrecht, 2005.
- [70] L. N. Shevrin, B. M. Vernikov, and M. V. Volkov, Lattices of semigroup varieties, *Russian Math. (Iz. VUZ)* **53** (2009), no. 3, 1–28; translation of *Izv. Vyssh. Uchebn. Zaved. Mat.* 2009, no. 3, 3–36.

- [71] K. P. Shum and X. M. Ren, *Completely Archimedean semigroups*, Proceedings of the International Mathematics Conference '94, 193–218, World Scientific, 1994.
- [72] A. L. Šmel'ken, Wreath products and varieties of groups, *Soviet Math. Dokl.* **5** (1964), 1099–1101; translation of *Dokl. Akad. Nauk SSSR* **157** (1964), no. 5, 1063–1065.
- [73] B. Southcott, A basis for the laws of a class of simple groups, *J. Austral. Math. Soc.* **17** (1974), no. 4, 500–505.
- [74] T. Tamura, The theory of constructions of finite semigroups I., *Osaka Math. J.* **8** (1956), no. 2, 243–261.
- [75] T. Tamura, Remark on the smallest semilattice congruence, *Semigroup Forum* **5** (1972), no. 1, 277–282.
- [76] A. Tarski, Equational logic and equational theories of algebras, in H. A. Schmidt *et al.* (eds.), *Contributions to Math. Logic* (Hannover, 1966), 275–288, North-Holland, Amsterdam, 1968.
- [77] A. V. Tishchenko, The finiteness of a base of identities for five-element monoids, *Semigroup Forum* **20** (1980), no. 2, 171–186.
- [78] A. V. Tishchenko, The wreath product of atoms of the lattice of semigroup varieties, *Trans. Moscow Math. Soc.* 2007, 93–118; translation of *Tr. Mosk. Mat. Obs.* **68** (2007), 107–132.
- [79] A. V. Tishchenko, On the lattice of subvarieties of the wreath product of the variety of semilattices and the variety of semigroups with zero multiplication, *J. Math. Sci. (N. Y.)* **221** (2015), no. 3, 436–451; translation of *Fundam. Prikl. Mat.* **19** (2014), no. 6, 191–212.
- [80] A. N. Trahtman, A basis of identities of the five-element Brandt semigroup (in Russian), *Ural. Gos. Univ. Mat. Zap.* **12** (1981), no. 3, 147–149.
- [81] A. N. Trahtman, The finite basis question for semigroups of order less than six, *Semigroup Forum* **27** (1983), no. 1–4, 387–389.
- [82] A. N. Trahtman, Some finite infinitely basable semigroups (in Russian), *Ural. Gos. Univ. Mat. Zap.* **14** (1987) no. 2, 128–131.

- [83] A. N. Trahtman, Finiteness of identity bases of five-element semigroups (in Russian), in E. S. Lyapin (ed.), *Semigroups and Their Homomorphisms*, 76–97, Ross. Gos. Ped. Univ., Leningrad, 1991.
- [84] A. N. Trahtman, Identities of a five-element 0-simple semigroup, *Semigroup Forum* **48** (1994), no. 3, 385–387.
- [85] B. M. Vernikov, Varieties of semigroups whose lattice of subvarieties is decomposable into a direct product (in Russian), *Ural. Gos. Univ. Mat. Zap.* **14** (1988), no. 3, 41–52.
- [86] B. M. Vernikov, On modular elements of the lattice of semigroup varieties, *Comment. Math. Univ. Carolin.* **48** (2007), no. 4, 595–606.
- [87] B. M. Vernikov, Special elements in lattices of semigroup varieties, *Acta Sci. Math. (Szeged)* **81** (2015), no. 1–2, 79–109.
- [88] B. M. Vernikov and M. V. Volkov, Lattices of nilpotent varieties of semigroups. II (in Russian), *Izv. Ural. Gos. Univ. Mat. Mekh.* 1(10) (1998), 13–33.
- [89] M. V. Volkov, The finite basis problem for finite semigroups: a survey, in P. Smith *et al.* (eds.), *Semigroups* (Braga, 1999), 244–279, World Sci. Publ., River Edge, NJ, 2000.
- [90] M. V. Volkov, The finite basis problem for finite semigroups, *Sci. Math. Jpn.* **53** (2001), no. 1, 171–199.
- [91] M. V. Volkov, On a question by Edmond W. H. Lee, *Izv. Ural. Gos. Univ. Mat. Mekh.* No. 7(36) (2005), 167–178.
- [92] M. V. Volkov and I. A. Gol'dberg, Identities of semigroups of triangular matrices over finite fields, *Math. Notes* **73** (2003), no. 4, 474–481; translation of *Mat. Zametki* **73** (2003), no. 4, 502–510.
- [93] P. M. Weichsel, A decomposition theory for finite groups with applications to  $p$ -groups, *Trans. Amer. Math. Soc.* **102** (1962), no. 2, 218–226.
- [94] W. T. Zhang and Y. F. Luo, The subvariety lattice of the join of two semigroup varieties, *Acta Math. Sin. (Engl. Ser.)* **25** (2009), no. 6, 971–982.
- [95] W. T. Zhang and Y. F. Luo, A new example of a minimal non-finitely based semigroup, *Bull. Aust. Math. Soc.* **84** (2011), no. 3, 484–491.

- [96] The GAP Group, GAP – Groups, Algorithms, and Programming, Version 4.8.6; 2016. <http://www.gap-system.org>
- [97] <http://www.cs.st-andrews.ac.uk/?q=node/162>
- [98] The On-Line Encyclopedia of Integer Sequences, 2010, <http://oeis.org>
- [99] <http://www.cs.unm.edu/~mccune/prover9/>
- [100] J. D. Mitchell and others, Semigroups - GAP package, Version 2.6, (2015).  
<https://gap-packages.github.io/Semigroups/>



## 2 Website

A website was developed under this project, available at [sgv.pythonanywhere.com](http://sgv.pythonanywhere.com), with the functionality already described in the introductory chapter.

### 2.1 Architecture

The main tools used to develop this site were:

Table 3: Main technologies used in this project

Technology	Description
Python	Server side programming
Cython	Server side programming in cpu-intensive functions
Prover9 / Mace4	Automatic demonstration / refutation of theorems
Flask	Web development framework
MySQL	Relational database
SQLAlchemy	Object-relational database mapper
GAP	Groups, Algorithms, Programming - a System for Computational Discrete Algebra
Graphviz	Construction of diagrams
JavaScript, JQuery, AJAX	Client-side (asynchronous) programming
HTML5, CSS3, Bootstrap	Browser Presentation
MathJax	Display math notation on browsers
<a href="http://www.pythonanywhere.com">www.pythonanywhere.com</a>	Development environment and web hosting

## CHAPTER 2 - WEBSITE

The architecture of the site can be depicted as:

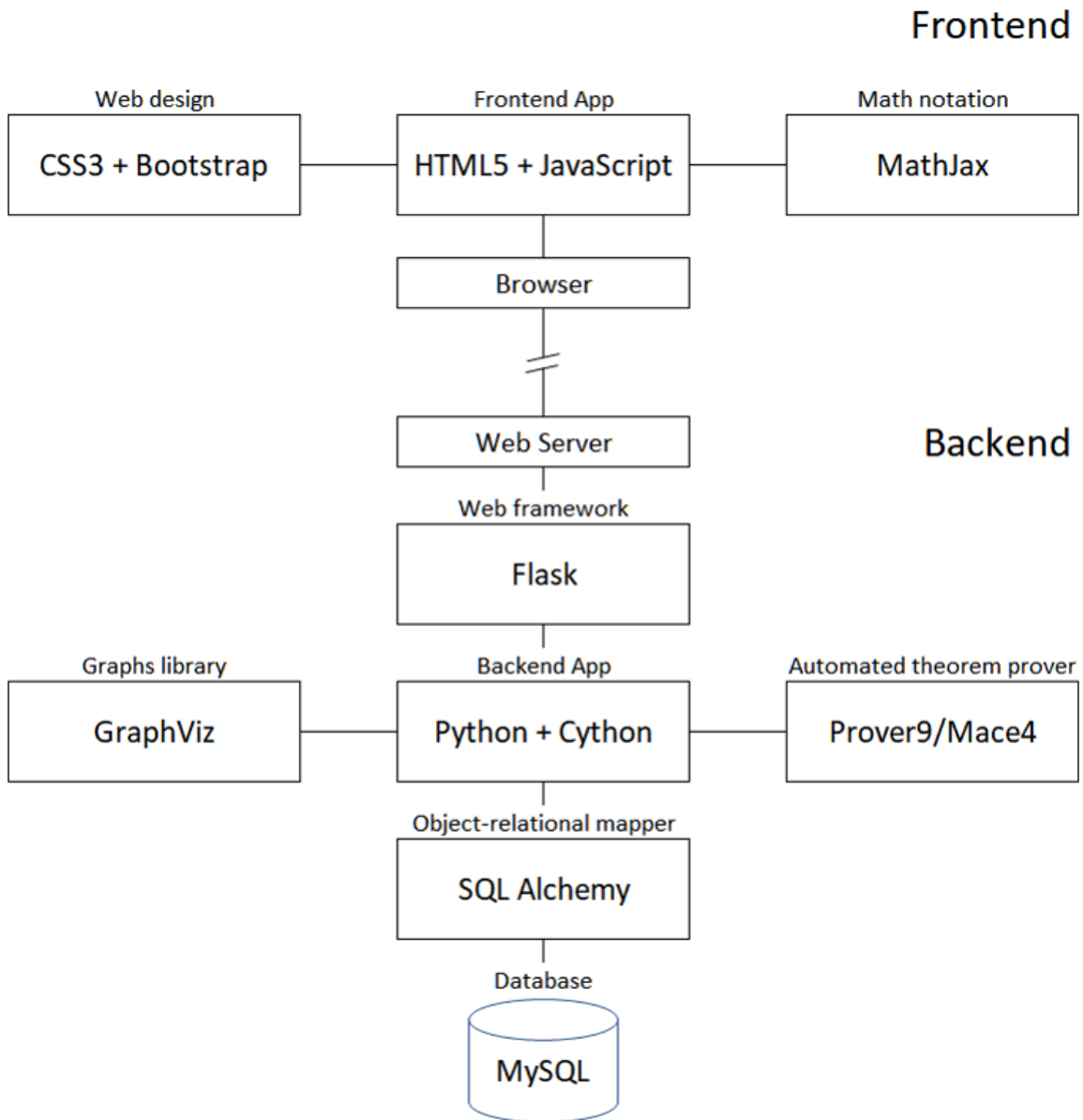

Figure 1: Website architecture

The main files containing all programming necessary to build this site are:

Table 4: Main files of this project

Library	Type	Description
spa.html	HTML	HTML5 file implementing a Single Page Application architecture. This file contains the entire HTML5, CSS and JavaScript code of the site, with the exception of user documentation file. The entire interface is loaded by the browser when the site is accessed. The components to display at each time are hided or unhided as needed.
instructions.html	HTML	User documentation file in HTML format.
flask_app.py	Python	Main server side application. Accepts all requests from the user browser, using JSON for data transport, and calls the relevant functions in the calculation libraries.
vartools.py	Python	Main library that interprets user input (multiplication tables) and formats outputs to display on site, as well providing several other funtions, like Cayley to semilat-tice decomposition or calculation of subsemigroups.
varlib.pyx	Cython	Implements the fastest algorithms used on the site, like finding the lexicographically minimum of the isomorphic copies of a given semigroup, or verifying if a semigroup satisfies the identity basis of any of the varieties in the database. Both operations runs about 1000x faster than on interpreted Python.
p9m4tools.py	Python	A collection of routines that interface with the automatic theorem prover Prover9 and the finite model builder Mace4, implements cache technics within RAM or SQL, or manipulate Prover9/Mace4 syntax, to support several funtions in the site (like presentation to Cayley or known identity basis equivalent or which imply the identities entered by the user), as well the search-lib*.pyx libraries which search for new varieties and identity basis.
auxtools.py	Python	Library which provides additional functions like Cayley to presentation, group varieties, and epigroup identities/unary operation.
mem.py	Python	Library which open channels to SQL cache tables and read other information to memory for faster site response.
specials.py	Python	A function library specific for band identification and processing of identity basis of band varieties.
toolslib.pyx	Cython	A C-compiled routine for speed which normalizes Prover9 syntax input to increase cache system hits.

Table 4: Main files of this project

<b>Library</b>	<b>Type</b>	<b>Description</b>
searchlibN.pyx	Cython	Implements Algorithm (A), in C-compiled Python, to find sets of semigroups that satisfy the same identities, and to propose candidate identities for identity basis of new proposed corresponding varieties. Relies on sets comparison to get suggestions about left terms on the candidate identities for the identity basis of new varieties, which increases speed over algorithm (B), which must analyse a greater number of candidate identities.
searchlib1.pyx	Cython	Implements Algorithm (B), in C-compiled Python, to propose candidate identities for the identity bases of new variety generated by the given semigroup.
TEX01a.py	Python	Implements a latex interpreter to read a .tex file with all information the known varieties into the site database, as well as formatting that information to HTML and MathJax. Also calculates intra-inclusions between all varieties, to display as a graph on the site.
groupools.py	Python	A collection of routines for additional automatic processing and discovery of identity basis for groups. Not yet used in the site but available for future use.
groupslib.py	Cython	A collection of additional C-compiled Python routines for group processing, when speed is necessary. Not yet used in the site but available for future use.

## 2.2 Finding the least (lexicographically) semigroup

Although not necessary to search for the identification system of a given semigroup if it exists on the database, a tool to find the least (lexicographically) semigroup isophormic to a given semigroup was developed, due to its high usefulness. The following optimized algorithm was developed, which will find the smallest element in each isomorphism class (for semigroups of order 10 it will take under one second on an average computer):

---

**Algorithm 1** Algorithm (M)

---

**Input:**  $order, mtable$ : order and multiplication table of a semigroup**Output:**  $minlex$ : multiplication table of the least (lexicographically) semigroup isophormic to the given semigroup

```

1: procedure MINLEX( $order, mtable$ )
2:    $minlex \leftarrow mtable$ 
3:   for  $i \leftarrow 1, order$  do
4:      $newElem[i] \leftarrow i$ 
5:   end for
6:   for all  $x \in$  order-permutations of order do
7:     for  $i \leftarrow 1, order$  do
8:        $newElem[x[i]] \leftarrow i$ 
9:     end for
10:     $equal \leftarrow True$ 
11:     $equal \leftarrow False$ 
12:     $smaller \leftarrow False$ 
13:    if  $newElem[mtable[x[1]][x[1]]] = 1$  then                                 $\triangleright$  Element (1,1) of the
multiplication table of the min.lex. is always 1
14:      for  $l \leftarrow 1, order$  do
15:        for  $c \leftarrow 1, order$  do
16:           $e \leftarrow newElem[mtable[x[l]][x[c]]]$ 
17:           $e0 \leftarrow minlex[l][c]$ 
18:          if  $equal = True$  then
19:            if  $e > e0$  then
20:               $stop \leftarrow True$ 
21:            exit for
22:          else if  $e < e0$  then
23:             $equal \leftarrow False$ 
24:             $smaller \leftarrow True$ 
25:          end if
26:        end if
27:         $a1[l][c] \leftarrow e$ 
28:      end for
29:      if  $stop = True$  then
30:        exit for
31:      end if
32:    end for
33:  end if
34:  if  $smaller = True$  then
35:     $minlex \leftarrow a1$ 
36:  end if
37: end for
38: return  $minlex$ 
39: end procedure

```

---

### 2.3 Inputting multiplication tables

A data entry tool was developed to permit input of a multiplication table of a semigroup  $S$ . Default elements are defined to be 1 to  $N$ , being  $N$  the *order* of the set, but base 0 instead of 1 or even specific elements can be defined by the user.

Elements can be separated by “,” or spaces, and optionally include “[” and “]” to enclose each line and/or the full multiplication table. If the elements are all single-digit, all or part of the separators can be omitted. For instance, all below input strings can be used to input the same multiplication table:

Table 5: Inputting a multiplication table

1 1 1 1 1 1 1 2	space separated
1,1,1,1,1,1,1,2	comma separated
1, 1, 1, 1, 1, 1, 1, 2	mixed commas and spaces
[1, 1, 1, 1, 1, 1, 1, 2]	”[” and ”]” enclosed
[ [ 1, 1, 1 ], [ 1, 1, 1 ], [ 1, 1, 2 ] ]	GAP syntax
111 111 112	separators omitted (only for single digit elements)
111111112	separators omitted (only for single digit elements)

Using the GAP syntax option, it’s possible to copy a multiplication table from GAP and paste it here. For example, to get the multiplication table of the group with  $ID=(5,1)$  at the SmallGroup GAP package:

```
gap> MultiplicationTable(SmallGroup(5,1));
[ [ 1, 2, 3, 4, 5 ], [ 2, 3, 4, 5, 1 ], [ 3, 4, 5, 1, 2 ], [ 4, 5, 1, 2,
3 ], [ 5, 1, 2, 3, 4 ] ]
```

The number of multiplication tables values must be exactly *order*<sup>2</sup>, otherwise an error will be returned. Only semigroups will be accepted, so the associativity property is checked.

Based on the given multiplication table and on database of varieties the tools will give a basis for the variety  $\text{var}(S)$ , if  $\text{var}(S) = \text{var}(B)$  for some variety whose identification system is available in the variety database.

Semigroups up to order 100 are accepted, but the representative in the isomorphism class of  $S$ , whose vector  $S$  is lexicographically the least, will only be computed in case the order of  $S$  is less or equal to 10, for site responsiveness reasons.

#### Define set of elements

The tool permits the definition of the elements of  $S$ , to use at the “multiplication table” option. The elements specified will also be used on other outputs.

- Default elements are named 1 to  $N$ , with  $N$  equal to the order of  $S$ .
- Another option is start elements with 0 up to  $N-1$ .

## CHAPTER 2 - WEBSITE

- A 3rd option is to enter other names for elements, separated by commas or spaces. If an insufficient number of elements is provided, the tool will use numbers to name the necessary additional elements.

## 2.4 Finding the identification system of a semigroup

A tool was developed to find the identifications systems of semigroups, including those of larger orders that happen to generate the same variety as a semigroup of smaller order.

The tool loops all varieties in the database and stops if all (Bas) identities of an identification system are satisfied and, at the same time, all (Max) identities of that identification system are violated, returning the respective variety.

When the user enters a semigroup into the site, the actions depicted in the function dependency graph (see Figure 2 on page 133) below will occur. The site will try to identify the corresponding variety, but many other calculations regarding the entered semigroup are implemented, and the results of those calculations are formatted and displayed at the user browser. The graph presents the main routines invoked from each of the libraries present previously. For instance in the graph it can be seen that the function `vartools.start_find_idsystem20` (find a variety given a Cayley table) will call the function `varlib.find_varieties20`, where the actual job will run, using compiled Python for greater speed.

Important to note that all function dependency graphs presented in this document only includes normally the 3 upper levels, to avoid readability issues of the graph.

---

**Algorithm 2** Algorithm (S)

---

**Input:** *order, mtable*: order and multiplication table of a semigroup**Output:** *variety*: ID of variety whose identification is satisfied by the given semigroup

```

1: procedure FINDIDENTIFICATONSYSTEM(order, mtable)
2:   var  $\leftarrow$  (1, 1)
3:   sat  $\leftarrow$  True
4:   variety  $\leftarrow$  Null
5:   for all varid, basmax, leftside, rightside  $\in$  VarietyIdentitiesDB do
6:     if varid  $\neq$  var then
7:       if sat = True then
8:         exit for
9:       else
10:        sat  $\leftarrow$  True
11:      end if
12:      var  $\leftarrow$  varid
13:    end if
14:    if sat = True then
15:      idSatisfy  $\leftarrow$  SATISFYIDENTITY(order, mtable, leftside, rightside)
16:      if  $\neg((\text{basmax} = (\text{Bas}) \wedge \text{idSatisfy} = \text{True}) \vee (\text{basmax} = (\text{Max}) \wedge$ 
idSatisfy = False)) then
17:        sat  $\leftarrow$  False
18:      end if
19:    end if
20:  end for
21:  if sat = True then
22:    variety  $\leftarrow$  var
23:  end if
24:  return variety
25: end procedure

26: function SATISFYIDENTITY(order, mtable, leftside, rightside)
27:   f1n  $\leftarrow$  Length(leftside)
28:   f2n  $\leftarrow$  Length(rightside)
29:   nvar  $\leftarrow$  Max(Max(leftside), Max(rightside))
30:   idSatisfy  $\leftarrow$  True
31:   for all v  $\in$  Product([i for i = 1 to order], repeat nvar times) do
32:     a1  $\leftarrow$  v[leftside[1]]
33:     for i1  $\leftarrow$  2, f1n do
34:       a1  $\leftarrow$  mtable[order * a1 + v[leftside[i1]]]
35:     end for
36:     a2  $\leftarrow$  v[rightside[1]]
37:     for i2  $\leftarrow$  2, f2n do
38:       a2  $\leftarrow$  mtable[order * a2 + v[rightside[i2]]]
39:     end for
40:     if a1  $\neq$  a2 then
41:       idSatisfy  $\leftarrow$  False
42:     exit for
43:   end if
44: end for
45:   return idSatisfy
46: end function

```

---

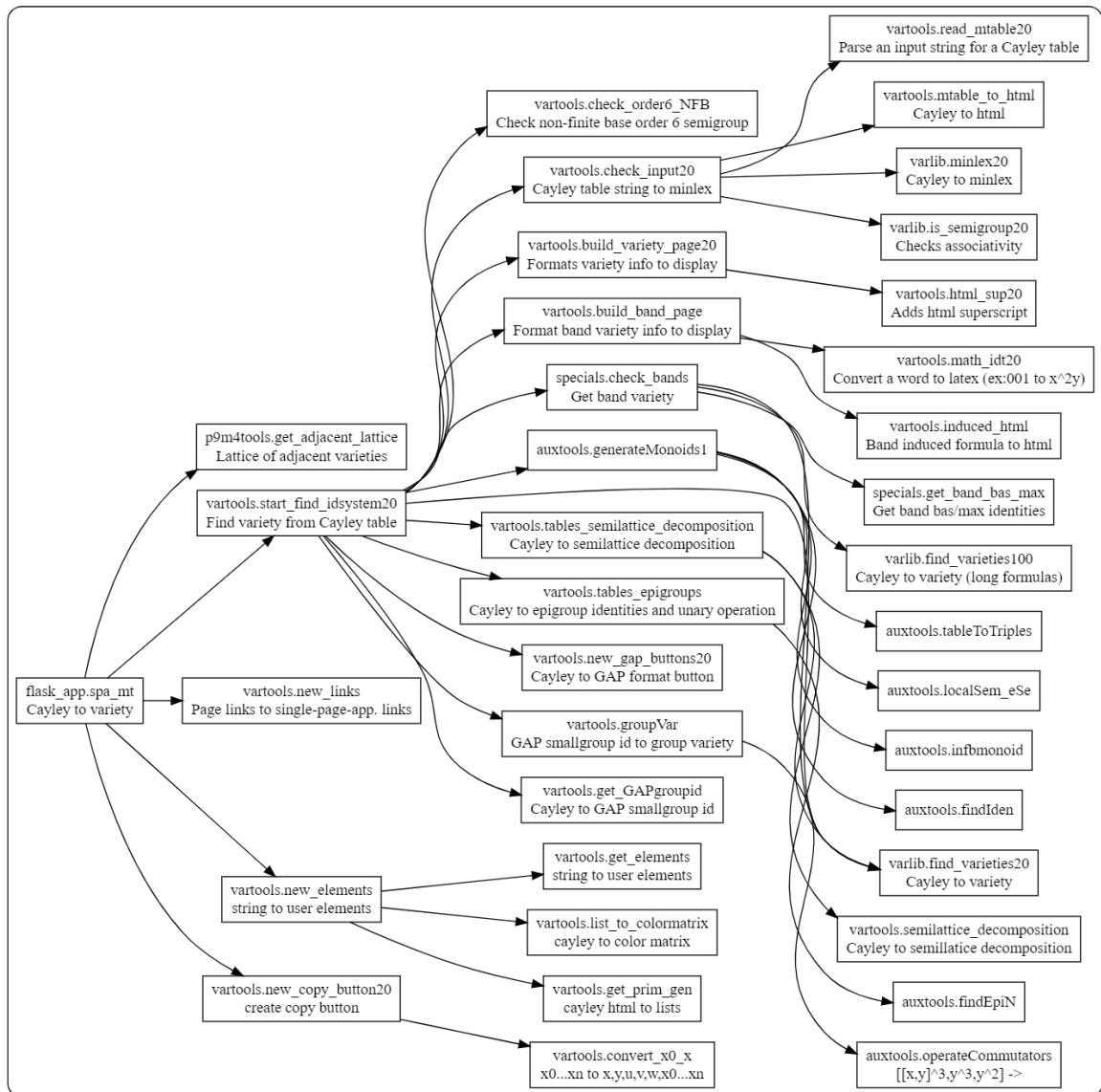

Figure 2: Function Dependency Graph: Cayley to Variety

## 2.5 Generating a semigroup from a given presentation

A tool was developed to identify a semigroup by entering a presentation in Prover9 syntax. The presentation is divided in two parts: the theory to follow and one or more relations (identities) between the initial elements of the set.

To specify the identities that define the theory and the relations, all Prover9 syntax can be used, but if the below subset of Prover9 syntax is used, the site will be able to use the cache system for greater calculations speed:

- Variables (with names started by "u", "v", "w", "x", "y" and "z"). No variables will be allowed at the "relations" part;
- Constants (with names started with a "0" to "9", "a" to "t", and "A" to "Z");
- Binary operation character "\*";
- Equal sign "=";
- Parentheses "(" and ")";
- To finalize each identity, the character "." must be used.

### Examples:

Consider the following example presentations, and how to enter corresponding theory and relations into the tool using Prover9 syntax:

Table 6: Inputting presentations

Presentation	Theory	Relations
$\langle a, e   ea^2 = a^2, e^2 = ae = e \rangle$ $= \{a, e, a^2, ea\}$	$x * (y * z) = (x * y) * z.$	$(e * a) * a = a * a.$ $e * e = a * e.$ $a * e = e.$
$\langle a   a^5 = 1 \rangle$ $= \{a, a^2, a^3, a^4, 1\}$	$x * (y * z) = (x * y) * z.$ $x * 1 = x. 1 * x = x.$	$((a * a) * a) * a = 1.$
$\langle a, e   ae = 0, ea = a, e^2 = e \rangle$ $\cup \{1\} = \{0, a, e, 1\}$	$x * (y * z) = (x * y) * z.$ $x * 0 = 0. 0 * x = 0.$ $x * 1 = x. 1 * x = x.$	$a * e = 0.$ $e * a = a.$ $e * e = e.$

The tool will create new elements of the set if necessary to close the multiplication table.

Entering a semigroup as a presentation (or using given identities to find or filter varieties) demands the use of an automated theorem prover (in this site Prover/Mace4). The following algorithm was developed:

---

**Algorithm 3** Algorithm (P) - Main Procedure
 

---

**Input:**  $P$ : presentation's theory and relations in Prover9 syntax

**Output:**  $err$ : error,  $elem$ : semigroup elements,  $mtable$ : multiplication table

```

1: procedure PRESENTATIONS(P)
2:    $SP, constants \leftarrow \text{NORMALIZE}(P)$  ▷ see notes
3:   if  $SP \in \text{cacheSQL}$  then
4:     return  $Null, elem, mtable$ 
5:   end if
6:    $clauses \leftarrow$  individual clauses of P
7:    $elem \leftarrow constants$ 
8:    $order \leftarrow \text{Length}(constants)$ 
9:    $elem_0 \leftarrow [1 \text{ to } order]$ 
10:   $mtable \leftarrow \emptyset$ 
11:   $stop \leftarrow False$ 
12:  while  $stop = False$  do
13:     $err, newOrder \leftarrow \text{PRESENTATIONLOOP}(P, clauses, order, elem, elem_0, mtable)$ 
14:    if  $err \neq Null$  then
15:      return  $err, \emptyset, \emptyset$ 
16:    end if
17:    if  $newOrder = order$  then
18:       $stop \leftarrow True$ 
19:    else
20:       $order \leftarrow newOrder$ 
21:       $stop \leftarrow False$ 
22:    end if
23:  end while
24:   $\text{WRITECACHESQL}(P, elem, mtable)$ 
25:  return  $Null, elem, mtable$ 
26: end procedure

```

---

**Algorithm 4** Algorithm (P) - Function PresentationLoop

---

```

1: function PRESENTATIONLOOP(P, clauses, order, elem, elem0, mtable)
2:   for l ← 1, order do
3:     for c ← 1, order do
4:       if mtable[l][c] = ∅ then
5:         exists ← False
6:         for all e ∈ elem do
7:           f1 ← elem[l] + “*” + elem[c] + “=” + e
8:           if f1 ∈ clauses then
9:             mtable[l][c] ← e
10:            exists ← True
11:          else
12:            f2 ← e + “=” + elem[l] + “*” + elem[c]
13:          end if
14:          if f2 ∈ clauses then
15:            mtable[l][c] ← e
16:            exists ← True
17:          end if
18:          if exists = True then
19:            exit for
20:          end if
21:        end for
22:        if exists = False then
23:          elements ← elem[l] + “*” + elem[c] + “=”
24:          exists ← False
25:          for all e ∈ reversed(elem) do
26:            f1 ← elements + e + “.”
27:            result, msg, errors ← PROVER9MACE4(Null, P, f1)
28:            if result = 2 then
29:              return msg, 0
30:            end if
31:            if result = 0 then
32:              mtable[l][c] ← e
33:              exists ← True
34:              exit for
35:            end if
36:          end for
37:          if exists = False then ▷ New element
38:            newOrder ← order + 1
39:            add [l, c] to elem0
40:            add “(” + elem[l] + “*” + elem[c] + “)” to elem
41:            add [“” × newOrder] to mtable ▷ New element line
42:            for m ← 1, newOrder − 1 do ▷ New element column
43:              add “” to mtable[m]
44:            end for
45:            mtable[l][c] ← “(” + elem[l] + “*” + elem[c] + “)”
46:            return Null, newOrder
47:          end if
48:        end if
49:      end if
50:    end for
51:  end for
52:  return Null, order
53: end function

```

---

Notes:

Line 3:, 4: and 24: of the main procedure are not mandatory to the algorithm. They implement a cache system to speed up the operation.

Line 2 of Main Procedure:

The NORMALIZE function finds a unique (as unique as possible) signature to a group of input clauses in Prover9. The goal is to record results of proofs on database with similar input clauses, even if they are entered in a different way. The routine:

- Removes all spaces and comments at the end of each formula
- Substitute all variable names by  $x,y,z,u,v,w,x_0\dots x_9,y_0\dots y_9,\dots$  on each formula
- Substitute all constant/function/predicate names by  $A..Z,A_0..A_9,B_0\dots B_9,\dots$  across all formulas
- Reorder clauses to get the lexical minimum (testing all non-variable names permutations)
- Does not change the internal order of each formula.
- The output can be used directly on Prover9, after substituting "»" by "all " and "«" by "exists ".

Examples:

- input = 'Y1 \* X1 = X2 \* Y2. X1 \* Y1 != Y2 \* X2. X1 \* Y1 != x \* y — Y2 \* X2 != y \* x.'
- output = 'A\*B!=C\*D.A\*B!=x\*y—C\*D!=y\*x.B\*A=D\*C.'
- input = '(all x all y (subset(x,y) <->(all z (member(z,x) ->member(z,y))))))'
- output '(»x»y(A(x,y) <->(»z(B(z,x)->B(z,y))))).'

Line 27 of PRESENTATIONLOOP function:

The function PROVER9MACE4 invokes Prover9, an automated theorem prover for first-order and equational logic, and Mace4, that searches for finite models and counterexamples. Parameter P is used as the assumptions input to both programs, launched in parallel, and f1 is the candidate element, used as a goal input. If a proof is found, the new element (variable *elements*, left part of f1) will be added to the semigroup.

The number of proofs needed can be very high, so a strategy to limit calls and also to speed-up the use of Prover9/Mace4 was implemented, see Figure 3 on page 138.

The dependency graph of this functionality, depicting the main functions called, can be seen in Figure 4 on page 139.

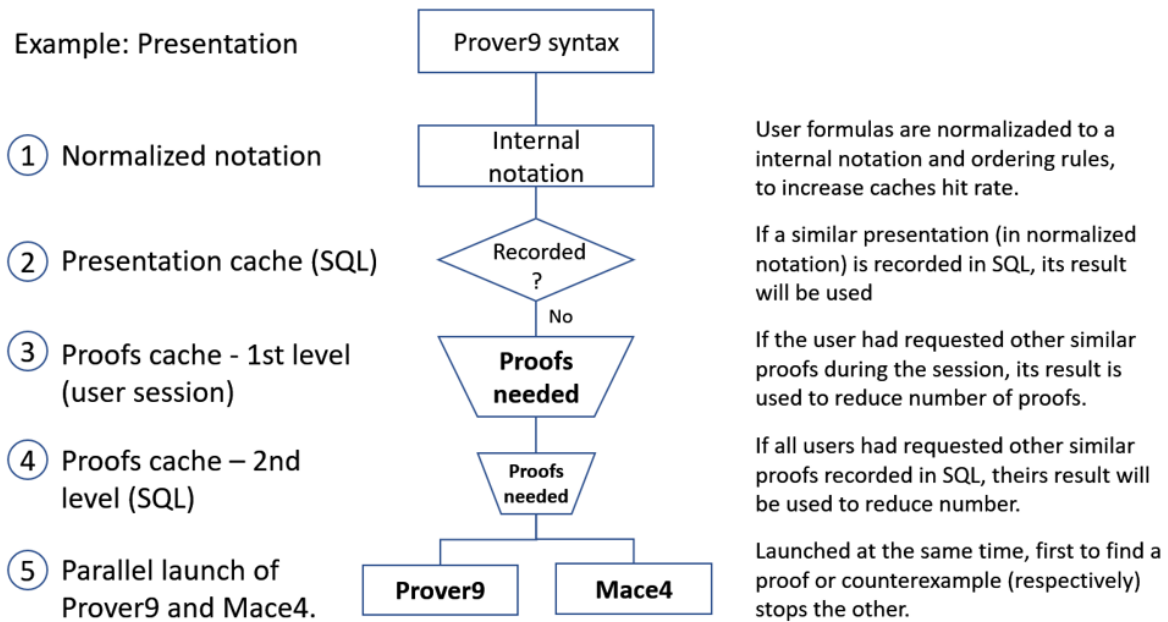

Figure 3: Cache implementation: Presentation to Cayley



## 2.6 Generating a presentation from a given semigroup

This tools permits to get a presentation starting from the multiplication table of a semigroup.

The dependency graph of this functionality, depicting the main functions called in each project library, follows:

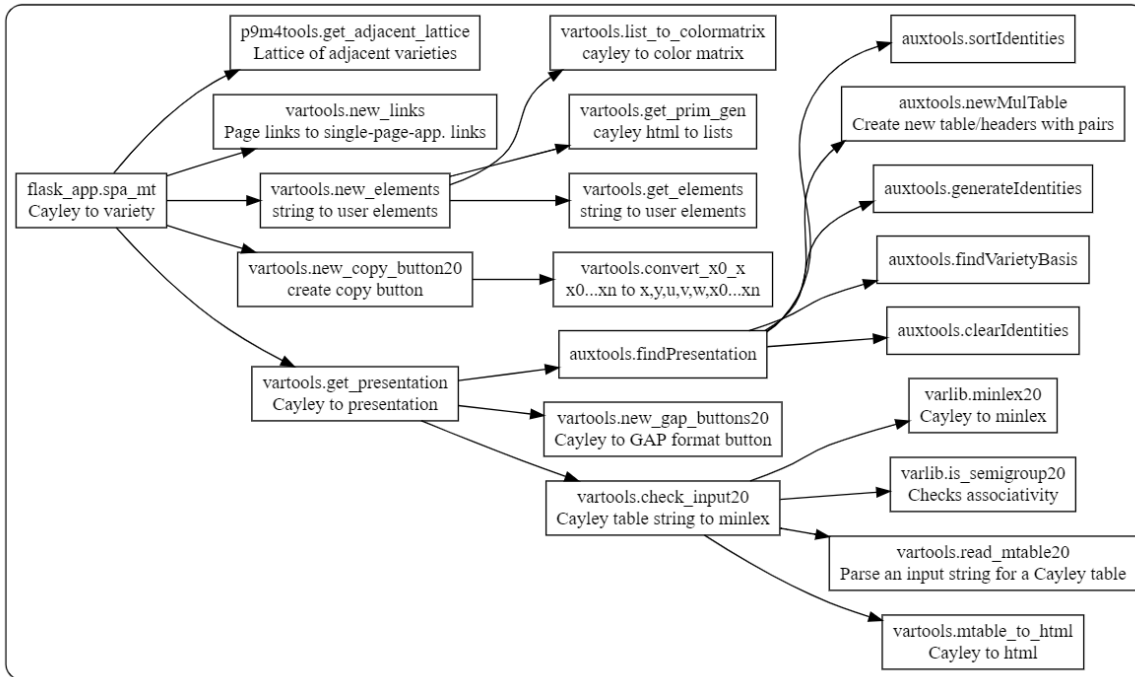

Figure 5: Function Dependency Graph: Cayley to Presentation

## 2.7 Testing equivalent identification systems

A tool was developed that will, by specifying one or more identities in Prover9 format, retrieve the variety whose identity basis is equivalent to the set of identities entered. To specify the identities, a subset of Prover9 syntax can be used for greater speed, since the cache system will be used:

- Variables (with names started by “u”, “v”, “w”, “x”, “y” and “z”).
- Binary operation character “\*”;
- Equal sign “=”;
- Parentheses “(“ and “)”;
- To finalize each identity, the character “.” must be used.

### Example:

If the identities “ $y=y*z. x=x*x.$ ” (spaces are optional) are entered, Variety (2,3), whose identity basis is the identity  $xy=x$ , will be displayed, as these sets of identities are equivalent. The following dependency graph illustrates the main functions called in each project library:

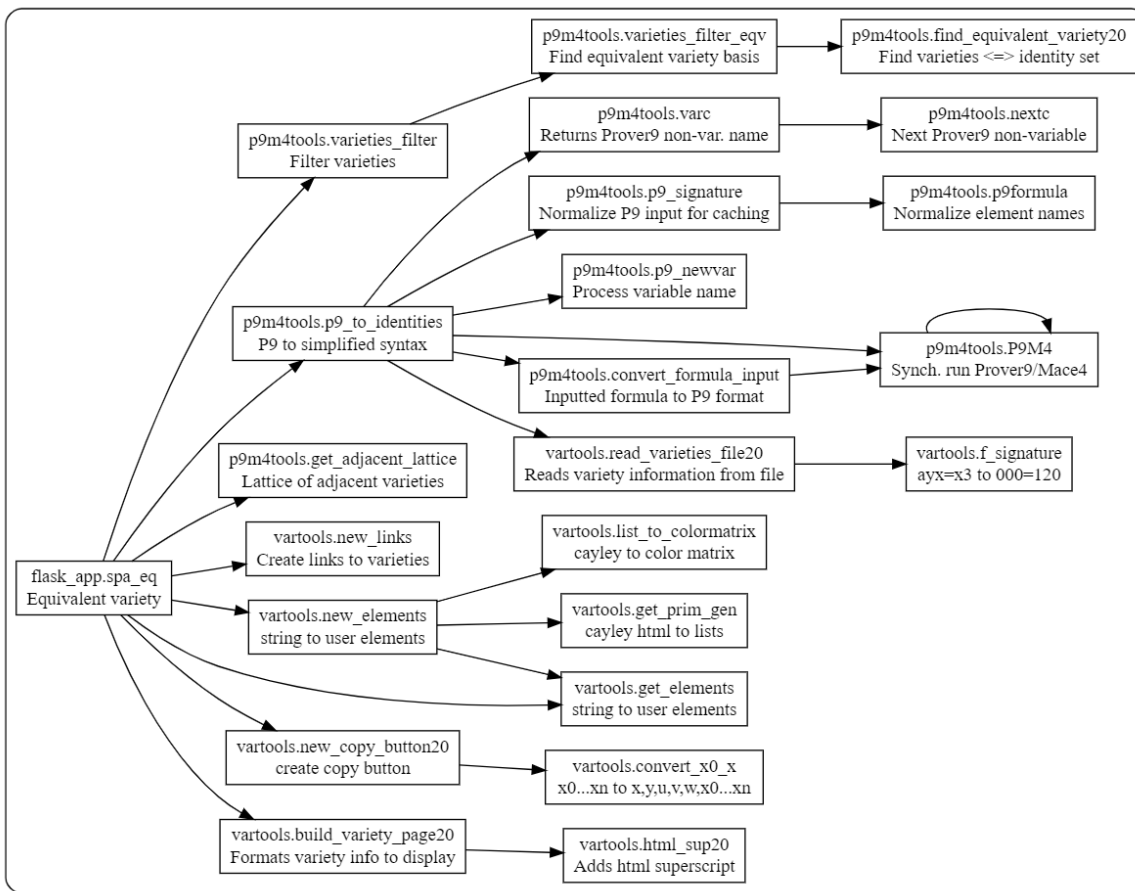

Figure 6: Function Dependency Graph: Variety basis equivalent to identities

## 2.8 Filtering varieties using conditions

Suppose we have some property and want to check which varieties in the database satisfy it. This can be done on the website, using these two distinct functionalities:

- (a) Returns the varieties whose identity basis is implied by the user’s assumptions.
- (b) Returns the varieties whose identity basis implies the user’s goals.

To specify the identities, a subset of Prover9 syntax can optionally be used for greater speed. In this case only variables with names started by “u”, “v”, “w”, “x”, “y” and “z”), the operation character “\*”, the equal sign “=”, parentheses “(“ and “)”, and “.” (to finalize each identity) can be used.

It’s not necessary to specify the associativity property, it will be included by default.

Prover9, an automatic theorem prover, and its accompanying program, Mace4, a finite model builder that look for countermodels, will run simultaneously to check the implications, according to the user’s choice, as in the following table:

Varieties whose identity basis is implied by the user’s assumptions		Varieties whose identity basis implies the user’s goals	
$assumptions \Rightarrow (identity\ basis \ \& \ goals)$		$(assumptions \ \& \ identity\ basis) \Rightarrow goals$	
Prover <i>Searches for proofs</i>	Finite Model Builder <i>Searches for models</i>	Prover <i>Searches for proofs</i>	Finite Model Builder <i>Searches for models</i>

Table 7: User options for filtering varieties

The following dependency graph illustrates the main functions called in each project library to implement this function:

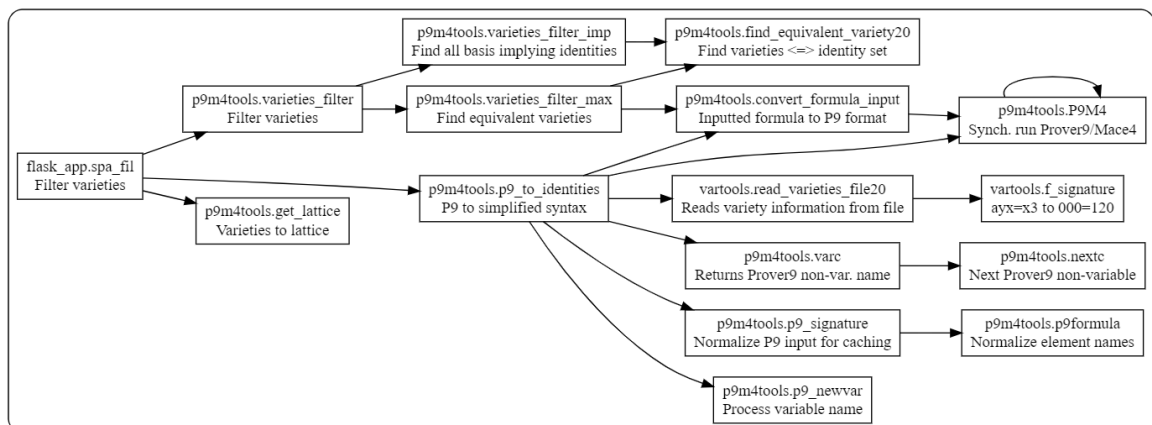

Figure 7: Function Dependency Graph: Variety basis which imply identities

## 2.9 Obtaining lattices of varieties

A tool was developed to obtain a lattice of a set of varieties created with the filtering tool.

### Example:

Get only the varieties from the database whose semigroups are bands. These semigroups satisfy the identity  $x^2 = x$ .

By filling, in the “Filter varieties” screen, the “Goals:” input field with the following string:  $x * x = x$ . and clicking “Prover9” in the option “Varieties whose identity basis implies the user’s goals:”, the filtering tool returns the 15 varieties below:

Table 8: Band varieties in the database

Variety	Identity basis (apart from $xx = x$ )	Semigroups in this variety
(1,1)	$x = y$	The trivial semigroup
(2,2)	$xy = yx$	Semilattices
(2,3)	$xy = x$	Left-zero semigroups
(2,4)	$xy = y$	Right-zero semigroups
(3,7)	$xyz = xzy$	Left normal bands
(3,8)	$xyz = yxz$	Right normal bands
(3,10)	$xyx = xy$	Semilattices of left-zero semigroups
(3,13)	$xyx = yx$	Semilattices of right-zero semigroups
(4,32)	$xyzx = xzyx$	Normal bands
(4,34)	$xyxz = xyz$	Left quasi-normal bands
(4,44)	$xyzy = xzy$	Right quasi-normal bands
(4,48)	$xyx = x$	Rectangular bands
(5,101)	$xyxzx = xyzx$	Regular bands
(5,102)	$xyzxz = xyz$	Left semi-normal bands
(5,142)	$xyz = xzxyz$	Right semi-normal bands

The lattice tool can then display the lattice of these varieties. If we use “ $x*x = x.x*y = y*x$ .”, only varieties whose semigroups are commutative bands will be obtained (only 3 varieties).

## 2.10 Extending the database: Finding generators and identity basis of unknown varieties

Two algebras generate the same variety if and only they satisfy the same identities. Since checking whether or not a finite semigroup satisfies or violates some identities is a task achievable by a computer, a methodology was developed to:

- (a) Given a set of semigroups whose varieties do not coincide with the known varieties present in the database (by checking that these semigroups do not satisfy any identity basis in the database), organize these semigroups into distinct subsets of semigroups that satisfy the same identities. Each subset now represents now a candidate new variety (generated by all of the semigroups in each subset, since they satisfy the same identities);
- (b) Given a candidate new variety, find identities which are candidates to be in the identity basis of this variety.

At the beginning of this project, these two tasks seemed overwhelming. The first demands that the computer test a sufficient number of identities to get relevant results. In a preliminary evaluation, it was calculated the need to test, for order 6 semigroups, about  $7.7^9$  different identities. If we multiply this by the variable combinations we need to test and by the number of semigroup operation calculations which increase with the size of each word to test, it becomes rapidly impossible with current computer average CPU power. The second task has the same problem. Although the number of satisfied entities can be much smaller, they can still be many thousands, and we too need to greatly reduce these number in order to reach the candidate identities for the new variety. If we rely only on an automatic theorem prover like Prover9/Mace4, it will be also extremely expensive on CPU power.

An algorithm to achieve the desired goals was designed and implemented, with two variants:

Algorithm (A), in C-compiled Python, find sets of semigroups that satisfy the same identities, and also proposes candidate identities for identity basis of new proposed corresponding varieties. Relies on sets comparison to get suggestions about left terms on the candidate identities for the identity basis of new varieties, which increases speed over algorithm (B), which must analyse a greater number of candidate identities. For a order 6 semigroup, the maximum time to reach the results is 10 minutes on average personal computer.

Algorithm (B), also in C-compiled Python, only propose candidate identities for the identity bases of new variety generated by the given semigroup. This algorithm does not get the same identity hints referred above for algorithm (A), so has much more candidate identities to test and reduce, resulting in significantly higher computation times (hours). But in certain cases it can achieve different results for the candidate identities.

The results of these two algorithms are presented in Chapter 3. The following section depicts the identity testing part shared by Algorithms (A) and (B):

---

**Algorithm 5** Algorithm (A)/(B) - Identities test routine

---

**Input:**  $S$ : semigroups set,  $maxWordSize$ : maximum word size,  $maxVars$ : maximum number of variables

**Output:**  $distinctResults$ : all distinct word solutions,  $resultsSequence$ : for each semigroup in input set, its sequence of word solutions as IDs in  $distinctResults$

```

1: procedure FINDBASISN( $S$ ,  $maxWordSize$ ,  $maxVars$ )
2:    $distinctResults \leftarrow \{\}$ 
3:    $resultsSequence \leftarrow \{\}$ 
4:   for  $wordSize \leftarrow 1, maxWordSize$  do ▷ Loop word sizes
5:      $numVar \leftarrow maxVars(wordSize)$ 
6:     ▷ Loop all words by using the Cartesian Product
7:     for all  $word \in X_{i=1}^{wordSize}[x_0, \dots, x_{numVar}]$  do
8:       for all  $s \in S$  do ▷ Loop all semigroups of input set
9:          $result \leftarrow \emptyset$ 
10:        ▷ Loop all variable values
11:        for all  $variables \in X_{i=1}^{wordSize}[0, \dots, numVar]$  do
12:           $result \leftarrow result + s[word, variables]$ 
13:        end for
14:        ▷ If necessary,  $result$  is extended to maximum size
15:        if  $numVar < numVarMax$  then
16:           $multiplier \leftarrow Order(s)^{numVarMax - numVar}$ 
17:          for  $i \leftarrow Size(results), -1, -1$  do
18:            for  $j \leftarrow 0, multiplier$  do
19:               $result(i * multiplier + j) \leftarrow result(i)$ 
20:            end for
21:          end for
22:        end if
23:
24:        if  $result \notin distinctResults$  then
25:          Insert  $ZIP(result)$  into hash  $distinctResults$ 
26:        end if
27:        if  $distinctResults.index \notin resultsSequence(s)$  then
28:          Insert  $distinctResults.index$  into hash  $resultsSequence(s)$ 
29:        end if
30:      end for
31:    end for
32:  end for
33:  return  $distinctResults, resultsSequence$ 
34: end procedure

```

---

The following figure illustrates the main libraries and functions involved in algorithm (A) implementation:

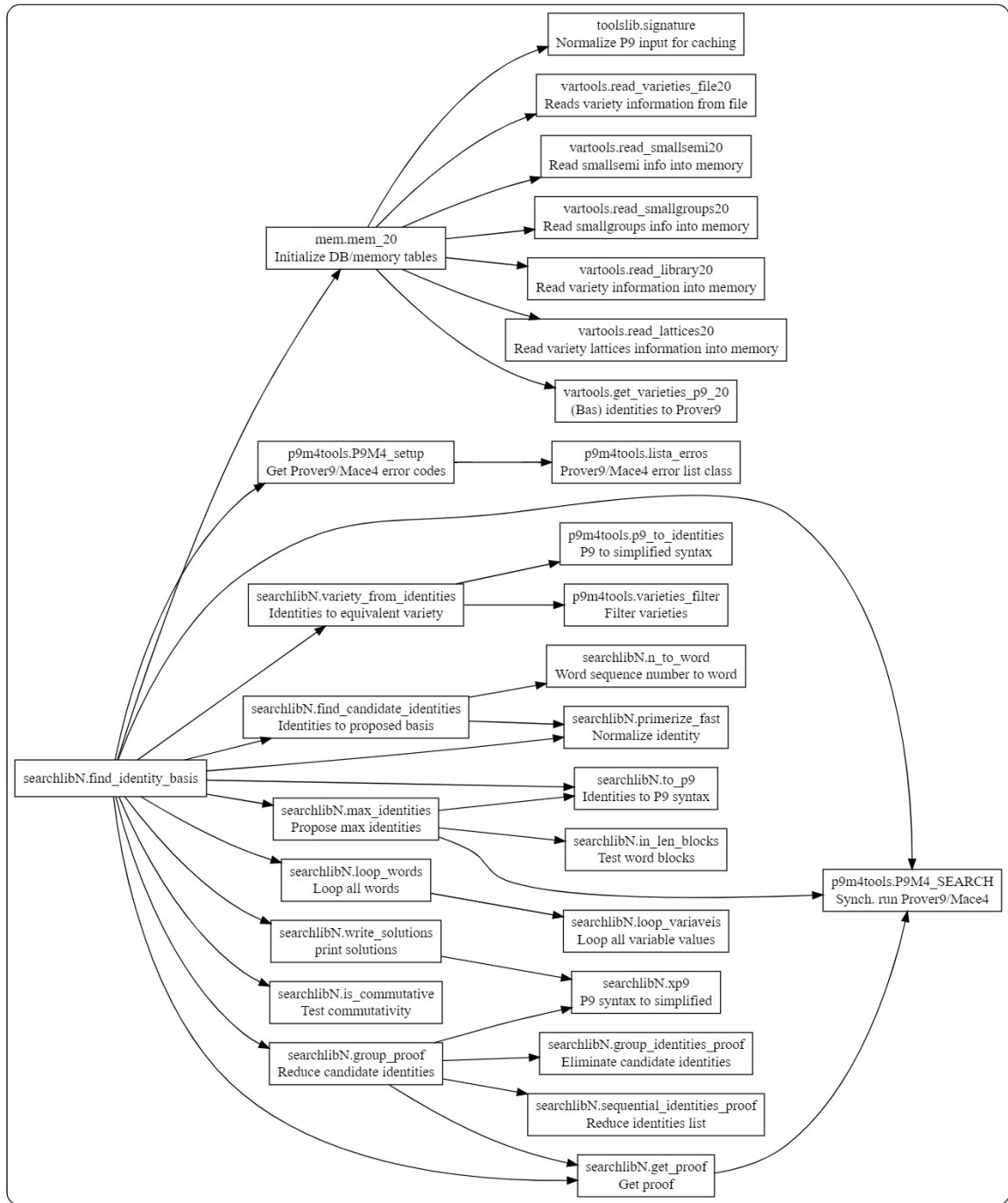

Figure 8: Function Dependency Graph: Extending the database



...Then the following HTML ready output, to be recorded into the site database is obtained:

```

3|1|0|Library ID|A.29.
3|1|1|Variety|<span class="math\_inline">\(\mathrm{V}(3,1)\)</span>
3|1|2|Primitive generator|<span class="math\_inline">\([111,111,112]\)</span>
3|1|3|Common generator|<span class="math\_inline">\(N_3 = \langle \mathsf{a} \mid \mathsf{a}^3 = 0 \rangle = \{0, \mathsf{a}, \mathsf{a}^2\}\)</span>
3|1|4|Prime decomposition|none
3|1|5|Identity basis|<span class="math\_inline">\(x^3 \approx xyz\)</span>,
<span class="math\_inline">\(xy \approx yx\)</span>
3|1|6|Identities defining maximal subvarieties|(1)<span
class="math\_inline">\(x^3 \approx x^2\)</span>
3|1|7|Maximal subvarieties|(1) <span class="math\_inline">\(\mathrm{V}(3,1)
\cap [x^3 \approx x^2] = \)</span>
<a href="http://sgv.pythonanywhere.com/var?id=V(4,3)">V(4,3)</a>
<span class="math\_inline">\( = \mathsf{var}\{G_4\}\)</span>
3|1|8|Other information on <span class="math\_inline">\(
\mathrm{V}(3,1)\)</span>|Self-dual
3|1|9|Other information on <span class="math\_inline">\(
\mathrm{V}(3,1)\)</span>|Cross with 4 subvarieties
3|1|10|References|J. Ara\uacuteco, J. P. Ara\uacuteco, P. J. Cameron,
E. W. H. Lee, J. Raminhos, A survey on varieties generated by
small semigroups and a companion website,
http://arxiv.org/abs/1911.05817

```

.....permitting the site to display the variety's information:

Variety ID:

Order:	3	Sequence:	1	Go!
--------	---	-----------	---	-----

<b>Variety</b>	V(3, 1)
<b>Identity basis</b>	$x^3 \approx xyz, xy \approx yx$ <input type="button" value="Prover9"/>
<b>Primitive generator</b>	[111, 111, 112]
<b>Common generator</b>	$N_3 = \langle a \mid a^3 = 0 \rangle = \{0, a, a^2\}$
<b>Prime decomposition</b>	none
<b>Identities defining maximal subvarieties</b>	(1) $x^3 \approx x^2$
<b>Maximal subvarieties</b>	(1) $V(3, 1) \cap [x^3 \approx x^2] = V(4, 3) = \text{var}\{G_4\}$
<b>Other information on V(3, 1)</b>	Self-dual
	Cross with 4 subvarieties
<b>References</b>	J. Araújo, J. P. Araújo, P. J. Cameron, E. W. H. Lee, J. Raminhos, A survey on varieties generated by small semigroups and a companion website, <a href="http://arxiv.org/abs/1911.05817">http://arxiv.org/abs/1911.05817</a> Variety 6.
<b>Some inclusions of varieties</b>	<p style="text-align: center;">Containing varieties</p> <p style="text-align: center;">Subvarieties</p> <p style="text-align: center;">Solid line: lower variety is a maximal subvariety of the upper one</p>

Figure 9: Site displaying a variety

...or the whole list of varieties:

Varieties in DB: 229													
Variety	Primitive Generator	Identity Basis	Common Generator	# max. subvar.									
V(1,1)	<table border="1"><tr><td>1</td></tr></table>	1	$x \approx y$	none	None								
1													
V(2,1)	<table border="1"><tr><td>1</td><td>1</td></tr><tr><td>1</td><td>1</td></tr></table>	1	1	1	1	$x^2 \approx xy$ $xy \approx yx$	$N_2 = \langle a \mid a^2 = 0 \rangle = \{0, a\}$	1					
1	1												
1	1												
V(2,2)	<table border="1"><tr><td>1</td><td>1</td></tr><tr><td>1</td><td>2</td></tr></table>	1	1	1	2	$x^2 \approx x$ $xy \approx yx$	$Sl_2 = \{0, 1\}$	1					
1	1												
1	2												
V(2,3)	<table border="1"><tr><td>1</td><td>1</td></tr><tr><td>2</td><td>2</td></tr></table>	1	1	2	2	$ax \approx a$	$LZ_2 = \langle a, b \mid a^2 = ab = a, b^2 = ba = b \rangle = \{a, b\}$	1					
1	1												
2	2												
V(2,4)	<table border="1"><tr><td>1</td><td>2</td></tr><tr><td>1</td><td>2</td></tr></table>	1	2	1	2	$xa \approx a$	$RZ_2 = \langle a, b \mid a^2 = ba = a, b^2 = ab = b \rangle = \{a, b\}$	1					
1	2												
1	2												
V(2,5)	<table border="1"><tr><td>1</td><td>2</td></tr><tr><td>2</td><td>1</td></tr></table>	1	2	2	1	$x^2a \approx a$ $xy \approx yx$	$Z_2 = \langle a \mid a^2 = 1 \rangle = \{a, 1\}$	1					
1	2												
2	1												
V(3,1)	<table border="1"><tr><td>1</td><td>1</td><td>1</td></tr><tr><td>1</td><td>1</td><td>1</td></tr><tr><td>1</td><td>1</td><td>2</td></tr></table>	1	1	1	1	1	1	1	1	2	$x^3 \approx xyz$ $xy \approx yx$	$N_3 = \langle a \mid a^3 = 0 \rangle = \{0, a, a^2\}$	1
1	1	1											
1	1	1											
1	1	2											
V(3,2)	<table border="1"><tr><td>1</td><td>1</td><td>1</td></tr><tr><td>1</td><td>1</td><td>1</td></tr><tr><td>1</td><td>1</td><td>3</td></tr></table>	1	1	1	1	1	1	1	1	3	$x^2a \approx xa$ $xy \approx yx$	none	2
1	1	1											
1	1	1											
1	1	3											
V(3,3)	<table border="1"><tr><td>1</td><td>1</td><td>1</td></tr><tr><td>1</td><td>1</td><td>1</td></tr><tr><td>1</td><td>2</td><td>3</td></tr></table>	1	1	1	1	1	1	1	2	3	$x^2a \approx xa$ $xy^2 \approx yx^2$	$J = \langle a, e \mid ae=0, ea=a, e^2=e \rangle = \{0, a, e\}$	1
1	1	1											
1	1	1											
1	2	3											
V(3,4)	<table border="1"><tr><td>1</td><td>1</td><td>1</td></tr><tr><td>1</td><td>1</td><td>1</td></tr><tr><td>3</td><td>3</td><td>3</td></tr></table>	1	1	1	1	1	1	3	3	3	$x^2 \approx xy$	none	2
1	1	1											
1	1	1											
3	3	3											
V(3,5)	<table border="1"><tr><td>1</td><td>1</td><td>1</td></tr><tr><td>1</td><td>1</td><td>2</td></tr><tr><td>1</td><td>1</td><td>3</td></tr></table>	1	1	1	1	1	2	1	1	3	$ax^2 \approx ax$ $x^2y \approx y^2x$	$\overleftarrow{J} = \langle a, e \mid ae=a, ea=0, e^2=e \rangle = \{0, a, e\}$	1
1	1	1											
1	1	2											
1	1	3											

Figure 10: Site displaying list of varieties

Besides the latex reading, the same tool calculates, by using the automated theorem prover Prover9/Mace4, all inclusions between varieties using their identity basis, to display in the site. All main project libraries and functions involved in this tool are presented in the following function dependency graph:

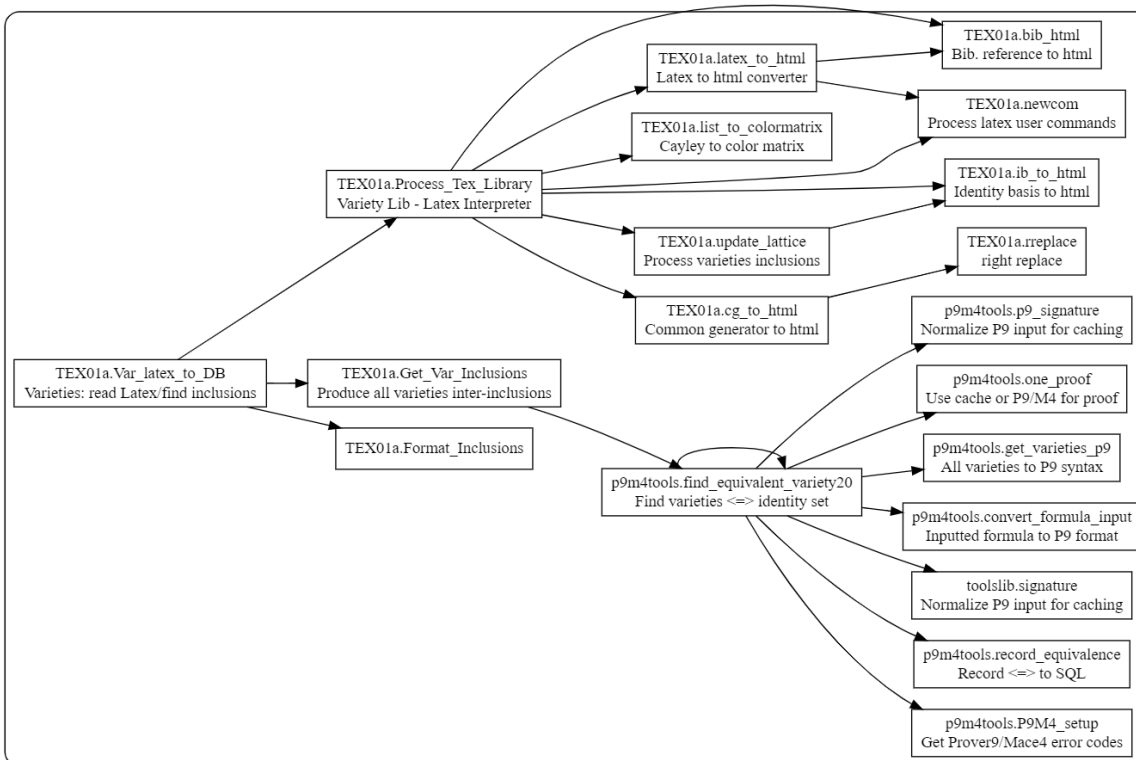

Figure 11: Function Dependency Graph: Latex reader/Inclusions finder

### 3 Open Problems

This chapter presents the results of running algorithms (A) and (B) against order 6 semigroups.

There are 28634 nonisomorphic semigroups of order 6, and from these, there are 2035 whose varieties do not coincide to any known variety generated by semigroups of order up to 5. Using the above referred algorithm (A), it was possible to divide these 2035 semigroups into 463 sets of semigroups that satisfy the same identities, corresponding to 414 new proposed varieties (since there are 45 known finitely-based and 4 known non-finitely based varieties generated by semigroups of order 6).

Additionally, the algorithms provide candidate identities for the identity basis for all these new varieties, or at least a candidate subset of the basis. Any enrichment of this candidate identities for the new varieties, resulting for optimizations in the algorithms, will be updated in the site. The current candidate identities and presented in this thesis, accompanied by all Cayley tables and the corresponding GAP smallsemi IDs, for each set of semigroups found.

The proofs of these new varieties represent open problems and a challenge to mathematicians.

The same methodology can be extended to find new candidate varieties generated by semigroups of order 7 or larger (within this work were found 73807 nonisomorphic semigroups of order 7 whose varieties do not coincide with known varieties stored in the site database).

Table 9: Open Problems

Id	Basis Proposal	Min.Lex.	GAP
PB[6,001]	(A)	[111111,111111,111111,111111,111211,112315]	(6,413)
	$xy^2 \approx zaz$	[111111,111111,111111,111112,111211,112315]	(6,414)
	(B)	[111111,111111,111111,111112,112143,111112]	(6,2416)
	$x^3 \approx yzy$	[111111,111111,111111,111112,112143,111122]	(6,2417)
	$x^3 \approx yzab$ $xyz \approx yxz$		
PB[6,002]	(Known basis)	[111111,111111,111111,111111,111211,113116]	(6,989)
	$x^2 \approx x^3$	[111111,111111,111111,111111,111211,113136]	(6,990)
	$xy^2 \approx yx^2$	[111111,111111,111111,111111,111211,113316]	(6,991)
	$xyz \approx xy^2z$	[111111,111111,111111,111111,111211,113336]	(6,992)
		[111111,111111,111111,111111,111455,112455]	(6,2909)
		[111111,111111,111111,111111,122255,122355]	(6,2917)
		[111111,111111,111111,111112,113151,111211]	(6,1052)
		[111111,111111,111111,111112,113153,111211]	(6,1053)
		[111111,111111,111111,111112,113155,113155]	(6,2930)
		[111111,111111,111111,111112,113155,113255]	(6,2931)
		[111111,111111,111111,111112,113353,111211]	(6,1054)
		[111111,111111,111111,111112,113355,113355]	(6,2932)
		[111111,111111,123333,123333,123333,123343]	(6,3059)
		[111111,111111,123333,123333,123334,123343]	(6,3061)
Note: Website W(6,1)			
PB[6,003]	(A)	[111111,111111,111111,111111,111212,112325]	(6,871)
	$xyx \approx xy^2$	[111111,111111,111111,111112,111212,112325]	(6,872)
	$xyz \approx yxz$	[111111,111111,111111,111122,111121,112234]	(6,2538)
	$x^4 \approx yzab$	[111111,111111,111111,111122,111122,112234]	(6,2539)
	(B)		
$xyx \approx xy^2$			
$xyz \approx yxz$			
$x^4 \approx yzab$			
PB[6,004]	(A)	[111111,111111,111111,111112,111113,112141]	(6,42)
	$x^2 \approx y^2z$		
	(B)		
$x^2 \approx y^2z$			
$xyz \approx zyx$			

Continued on next page

Table 9 – Continued from previous page

Id	Basis Proposal	Min.Lex	GAP
PB[6,005]	(A)	[111111,111111,111111,111112,111113,112142]	(6,338)
	$xy^2 \approx z^2a$	[111111,111111,111111,111112,111123,112141]	(6,481)
	(B)	[111111,111111,111111,111112,111123,112142]	(6,1485)
	$x^3 \approx y^2z$		
	$x^3 \approx yzab$ $xyz \approx zyx$		
PB[6,006]	(A)	[111111,111111,111111,111112,111124,112245]	(6,2579)
	$xy^2 \approx yxy$	[111111,111111,111112,111112,111123,112135]	(6,2579)
	$xyz \approx xzy$	[111111,111111,111112,111211,111123,112235]	(6,5117)
	$x^2y^2 \approx x^3y$	[111111,111111,111112,111212,111123,112135]	(6,5117)
PB[6,007]	(A)	[111111,111111,111111,111112,111151,112214]	(6,2800)
	$xy^2 \approx x^2y$	[111111,111111,111112,111112,111151,111214]	(6,2800)
	$xyz \approx xzy$	[111111,111111,111112,111211,111151,112213]	(6,5346)
	$xy^2 \approx y^2x$	[111111,111111,111112,111212,111151,112113]	(6,5346)
		[111111,111111,111112,111441,111441,112123]	(6,5465)
		[111111,111111,111112,111441,111442,112113]	(6,5465)
		[111111,122222,122222,122222,122223,122335]	(6,2844)
		[111111,122222,122222,122223,122223,122235]	(6,2844)
		[111111,122222,122222,122223,122232,122334]	(6,5365)
		[111111,122222,122222,122223,122233,122324]	(6,5365)
PB[6,008]	(A)	[111111,111111,111111,111112,112114,111113]	(6,413)
	$xyx \approx z^2a$	[111111,111111,111111,111112,112114,111123]	(6,414)
		[111111,111111,111111,111112,112124,111113]	(6,2416)
		[111111,111111,111111,111112,112124,111123]	(6,2417)
PB[6,009]	(A)	[111111,111111,111111,111112,112143,112141]	(6,583)
	$x^3 \approx yz^2$ $x^2y \approx yxy$	[111111,111111,111111,111112,112143,112142]	(6,2494)
PB[6,010]	(A)	[111111,111111,111111,111112,113151,111214]	(6,2797)
	$xyx \approx xy^2$	[111111,111111,111111,111112,113153,111214]	(6,2798)
	$xyz \approx yxz$	[111111,111111,123333,123333,123334,123345]	(6,5480)
	$x^3y \approx x^4y$		
	(B)		
	$xyx \approx xy^2$		
	$xyz \approx yxz$ $xyza \approx x^2yza$ $xyx \approx xy^2$ $xyz \approx yxz$ $xyza \approx x^2yza$		

Continued on next page

Table 9 – Continued from previous page

Id	Basis Proposal	Min.Lex	GAP
PB[6,011]	(A)	[111111,111111,111111,111112,121451,111113]	(6,2638)
	$xyx \approx xy^2$ $xy^2 \approx yxy$ $xyz \approx x^2yz$	[111111,111111,111111,111112,121452,111113]	(6,2639)
PB[6,012]	(B)		
	$xyx \approx xy^2$ $xyx \approx yx^2$ $xyz \approx x^2yz$		
PB[6,012]	(A)	[111111,111111,111111,111114,111121,113116]	(6,2604)
	$x^2y \approx x^3y$	[111111,111111,111111,111114,111121,113136]	(6,2605)
	$xyx \approx yxy$	[111111,111111,111111,111114,111124,113116]	(6,2605)
	$xy^2 \approx xy^3$	[111111,111111,111111,111114,111124,113136]	(6,2609)
	$x^2y^2 \approx xyx$	[111111,111111,111111,111211,112115,113116]	(6,2653)
	$xyxz \approx x^2yz$	[111111,111111,111111,111211,112215,113316]	(6,2654)
	(B)	[111111,111111,111111,112114,112124,113116]	(6,2654)
	$xyx \approx yxy$	[111111,111111,111333,121444,121444,121445]	(6,5858)
	$xyz \approx xy^2z$		
	PB[6,013]	(A)	[111111,111111,111111,111114,111121,113416]
$x^2y \approx x^3y$		[111111,111111,111111,111114,111121,113436]	(6,2607)
$xyz \approx yxz$		[111111,111111,111111,111114,111124,113446]	(6,2610)
$x^2yx \approx xyx$		[111111,111111,111113,111113,111121,113416]	(6,2667)
$xy^2x \approx x^2y^2$		[111111,111111,111113,111113,111123,113436]	(6,2669)
(B)		[111111,111111,111113,111113,111123,113446]	(6,2670)
$x^2y \approx x^3y$		[111111,111111,111333,123444,123444,123445]	(6,5859)
$xyx \approx x^2yx$		[111111,111222,111222,123444,123444,123445]	(6,5861)
$xyz \approx yxz$			
$x^2yzaz \approx xaz^2yx$			

Continued on next page

Table 9 – Continued from previous page

Id	Basis Proposal	Min.Lex	GAP
PB[6,014]	(Known basis)	[111111,111111,111111,111114,112111,111116]	(6,989)
	$x^2 \approx x^3$	[111111,111111,111111,111114,112114,111116]	(6,991)
	$x^2y \approx y^2x$	[111111,111111,111111,111144,111155,112155]	(6,2930)
	$xyz \approx xy^2z$	[111111,111111,111112,111141,111151,111141]	(6,990)
		[111111,111111,111112,111141,111151,112111]	(6,1052)
		[111111,111111,111112,111141,111151,112141]	(6,1053)
		[111111,111111,111112,111144,111155,111155]	(6,2909)
		[111111,111111,111112,111144,111155,112155]	(6,2931)
		[111111,111111,111113,111113,111213,111116]	(6,992)
		[111111,111111,111113,111123,111213,111116]	(6,1054)
		[111111,111111,111133,111133,111155,111255]	(6,2932)
		[111111,111122,111122,111123,111155,111155]	(6,2917)
		[111111,112222,113333,113333,113333,113343]	(6,3059)
		[111111,112222,113333,113333,113334,113343]	(6,3061)
Note: Website W(6,2)			
PB[6,015]	(A)	[111111,111111,111111,111114,112111,111416]	(6,1039)
	$x^2 \approx x^3$	[111111,111111,111111,111114,112114,111446]	(6,1044)
	$xy^2 \approx yxy$	[111111,111111,111111,111144,111455,112455]	(6,2938)
	$xyz \approx xzy$	[111111,111111,111112,111141,111454,111141]	(6,1044)
	(B)	[111111,111111,111112,111144,111455,111455]	(6,2938)
	$x^2 \approx x^3$	[111111,111111,111113,111113,111213,113336]	(6,1101)
	$xyz \approx xzy$	[111111,111122,111122,111122,122255,122355]	(6,3022)
	$xyz \approx yxz$	[111111,111122,111122,111123,122255,122255]	(6,3022)
	[111111,112222,123333,123333,123333,123343]	(6,3064)	
PB[6,016]	(A)	[111111,111111,111111,111114,112111,121156]	(6,1040)
	$x^2 \approx x^3$	[111111,111111,111111,111114,112111,122156]	(6,1042)
	$xyx \approx yxy$	[111111,111111,111112,111141,123151,111141]	(6,1098)
	$x^2y^2 \approx xyx$	[111111,111111,111112,111141,123152,111141]	(6,1099)
	$xyz^2 \approx xyzzy$		
	(B)		
$x^2 \approx x^3$			
$xyx \approx yxy$			
$xyx \approx x^2yx$			
$xyza \approx xy^2za$			

Continued on next page

Table 9 – Continued from previous page

Id	Basis Proposal	Min.Lex	GAP
PB[6,017]	(A)	[111111,111111,111111,111114,112111,121456]	(6,1041)
	$x^2 \approx x^3$	[111111,111111,111111,111114,112111,122456]	(6,1043)
	$xyx \approx yx^2$	[111111,111111,111111,111114,112114,121456]	(6,1045)
	$xy^2x \approx x^2y^2$	[111111,111111,111111,111114,112114,122456]	(6,1046)
	$xyzx \approx xzyx$	[111111,111111,111111,111124,112111,121456]	(6,1062)
	(B)	[111111,111111,111111,111124,112111,122456]	(6,1063)
	$x^2 \approx x^3$	[111111,111111,111112,111141,123454,111141]	(6,1100)
	$xyx \approx yx^2$	[111111,111111,111112,112141,123454,112141]	(6,1134)
	$x^2y^2 \approx xy^2x$	[111111,111111,111113,111113,111213,123356]	(6,1102)
	$xyza \approx yxza$		
PB[6,018]	(A)	[111111,111111,111111,111114,112121,111416]	(6,2612)
	$x^3 \approx x^4$	[111111,111111,111111,111114,112124,111446]	(6,2614)
	$xy^2 \approx yxy$	[111111,111111,111112,111141,111451,111112]	(6,2612)
	$xyz \approx xzy$	[111111,111111,111112,111141,111454,111142]	(6,2614)
	(B)	[111111,111111,111113,111113,111221,113316]	(6,2671)
	$x^2y \approx x^3y$	[111111,111111,111113,111113,111223,113336]	(6,2672)
	$xyz \approx xzy$	[111111,111111,111113,111123,111121,113316]	(6,2671)
	$xyz \approx yxz$	[111111,111111,111113,111123,111123,113336]	(6,2672)
		[111111,111111,111113,111211,111221,113116]	(6,5158)
		[111111,111111,111113,111211,111223,113136]	(6,5159)
		[111111,111111,111113,111213,111221,113316]	(6,5159)
		[111111,111111,111113,111213,111223,113336]	(6,5161)
		[111111,111111,111133,111211,113155,113255]	(6,5421)
		[111111,111111,111133,111212,113155,113155]	(6,5421)
		[111111,112222,123333,123333,123333,123344]	(6,5483)
		[111111,112222,123333,123333,123334,123334]	(6,5483)
	[111111,112222,123333,123333,123343,123344]	(6,9396)	
PB[6,019]	(A)	[111111,111111,111111,111122,111133,112141]	(6,583)
	$x^3 \approx y^2z$	[111111,111111,111111,111122,111133,112142]	(6,2494)
	$xyx \approx xy^2$		
	(B)		
$x^3 \approx y^2z$			
$x^3 \approx yzab$			
$xyx \approx xy^2$			

Continued on next page

Table 9 – Continued from previous page

Id	Basis Proposal	Min.Lex	GAP
PB[6,020]	(A) $xy^2 \approx x^2y$ $xyz \approx xzy$ $x^4 \approx yzab$ (B) $x^2y \approx xy^2$ $xyz \approx xzy$ $x^4 \approx yzab$	[111111,111111,111111,111122,111133,112244]	(6,2558)
PB[6,021]	(A) $x^2y \approx x^3y$ $xyx \approx yx^2$ $xyzx \approx xzyx$ (B) $x^2y \approx x^3y$ $xyx \approx yx^2$ $xyza \approx yxza$ $x^2y^2x \approx x^2y^3$	[111111,111111,111111,111124,112124,121456] [111111,111111,111111,111124,112124,122456] [111111,111111,111123,111123,111223,123356]	(6,2636) (6,2637) (6,2705)
PB[6,022]	(A) $x^2 \approx x^3$ $xyx \approx yx^2$ $xyzx \approx xzyx$ (B) $x^2 \approx x^3$ $xyx \approx yx^2$ $xyza \approx yxza$	[111111,111111,111111,111144,113456,133456] [111111,111122,111122,111122,122456,124456] [111111,111123,111123,111123,123256,123356] [111111,111123,111123,111123,123356,123256]	(6,3339) (6,3889) (6,3930) (6,3932)
PB[6,023]	(A) $x^2y \approx x^3y$ $xyx \approx xy^2$ $xy^2 \approx xy^3$ $xyzx \approx xzyx$ (B) $xyx \approx xy^2$ $xyz \approx xyxz$ $xyzx \approx xzyx$	[111111,111111,111111,111211,113151,666666] [111111,111111,111111,111211,113155,113166] [111111,111111,111111,111211,113351,666666] [111111,111111,111111,111211,113355,113366] [111111,111111,112111,444444,444444,444456] [111111,111111,112111,444444,444444,445456] [111111,111111,123133,444444,123133,123135] [111111,111111,123333,123333,123343,126666]	(6,5522) (6,5524) (6,5528) (6,5530) (6,9541) (6,9542) (6,9642) (6,9639)

Continued on next page

Table 9 – Continued from previous page

Id	Basis Proposal	Min.Lex	GAP
PB[6,024]	(A)	[111111,111111,111111,111211,113156,113156]	(6,5525)
	$x^2y \approx x^3y$	[111111,111111,111111,111211,113356,113356]	(6,5531)
	$xyz \approx yxz$	[111111,111111,123336,123336,123346,123336]	(6,9619)
	$x^2y^2 \approx xy^2$	[111116,111116,111116,111216,113156,111116]	(6,5550)
	(B)	[111116,111116,111116,111216,113356,111116]	(6,5560)
	$xyz \approx yxz$	[111116,111116,123336,123336,123346,111116]	(6,9633)
	$xyz \approx x^2yz$	[111155,111155,111155,111255,111155,113156]	(6,5554)
		[111155,111155,111155,111255,111155,113356]	(6,5564)
		[111155,111155,112155,111456,111155,111155]	(6,9544)
		[111155,122256,122256,122356,111155,111155]	(6,9662)
	[111444,111444,112444,111444,111444,111456]	(6,9547)	
PB[6,025]	(A)	[111111,111111,111111,111211,113156,113165]	(6,5380)
	$x^2y \approx x^4y$	[111111,111111,111111,111211,113356,113365]	(6,5382)
	$xyz \approx yxz$	[111111,111111,123336,123336,123346,126663]	(6,5498)
	$xy^3 \approx x^2yx$	[111111,111111,123355,123355,125533,125534]	(6,5509)
	(B)	[111116,111116,111116,111216,113156,666661]	(6,2847)
	$xyx \approx x^2y^3$	[111116,111116,111116,111216,113356,666661]	(6,2848)
	$xyz \approx yxz$	[111116,111116,123336,123336,123346,666661]	(6,5872)
	$xyz \approx x^3yz$	[111155,111155,111155,113455,555511,555512]	(6,2869)
		[111155,111155,112155,111456,555511,555511]	(6,2878)
		[111155,122256,122256,122356,555511,555511]	(6,5879)
	[111444,111444,113446,444111,444121,444111]	(6,2885)	
	[111444,111444,113455,444111,444111,444112]	(6,2886)	
PB[6,026]	(A)	[111111,111111,111111,111211,113156,113356]	(6,5526)
	$xyz \approx yxyz$		
	$xyzx \approx xzyx$		
	(B)		
	$xyx \approx yx^2$		
$xyz \approx xy^2z$			
$xyzx \approx xzyx$			
PB[6,027]	(A)	[111111,111111,111111,111211,113156,666666]	(6,5527)
	$x^2y \approx x^3y$	[111111,111111,111111,111211,113356,666666]	(6,5532)
	$xyx \approx xy^2$	[111111,111111,112111,111456,555555,555555]	(6,9539)
	$x^2yx \approx xyx$	[111111,111111,123336,123336,123346,666666]	(6,9643)
	(B)		
	$xyx \approx xy^2$		
$xyx \approx x^2yx$			
$xyz \approx xyxz$			

Continued on next page

Table 9 – Continued from previous page

Id	Basis Proposal	Min.Lex	GAP
PB[6,028]	(A)	[111111,111111,111111,111411,112111,666666]	(6,3362)
	$x^2 \approx x^3$	[111111,111111,111111,111414,112111,111616]	(6,3364)
	$xy^2 \approx x^2y$	[111111,111111,111111,111414,555555,112414]	(6,5894)
	$xyz \approx xzy$	[111111,111111,111111,111444,111555,112444]	(6,5912)
	(B)	[111111,111111,111111,112111,555555,555556]	(6,3379)
	$x^2 \approx x^3$	[111111,111111,111112,111411,555555,112111]	(6,3619)
	$xyz \approx xzy$	[111111,111111,111112,111411,555555,555555]	(6,6173)
	$xyz \approx x^2yz$	[111111,111111,111112,111414,555555,111414]	(6,6155)
		[111111,111111,111112,111414,555555,112414]	(6,6157)
		[111111,111111,111112,111441,111551,112111]	(6,3621)
		[111111,111111,111112,111444,111555,111444]	(6,5919)
		[111111,111111,111112,111444,111555,112444]	(6,6160)
		[111111,111111,111112,444444,444454,112111]	(6,3623)
		[111111,111111,111112,444444,444454,444444]	(6,6178)
		[111111,111111,111112,444444,444455,444455]	(6,6181)
		[111111,111111,113113,444444,444444,113123]	(6,9817)
		[111111,121222,333333,121222,121222,121242]	(6,4002)
		[111111,121222,333333,121222,121224,121242]	(6,4004)
		[111111,122222,122222,122222,122322,166666]	(6,3972)
		[111111,122222,122222,122223,155555,122322]	(6,3985)
	[111111,122222,122222,122223,155555,155555]	(6,6625)	

Continued on next page

Table 9 – Continued from previous page

Id	Basis Proposal	Min.Lex	GAP
PB[6,029]	(A)	[111111,111111,111111,111416,112111,111416]	(6,3364)
	$x^2 \approx x^3$	[111111,111111,111111,111446,112446,111446]	(6,5919)
	$x^2y \approx xy^2$	[111111,111111,111112,111451,111451,112111]	(6,3621)
	$xyz \approx yxz$	[111111,111111,111112,111454,111454,111454]	(6,5912)
	(B)	[111111,111111,111112,111454,111454,112454]	(6,6160)
	$x^2 \approx x^3$	[111111,122226,122226,122226,122326,122226]	(6,3972)
	$x^2y \approx xy^2$	[111111,122226,122226,122236,122326,122226]	(6,3985)
	$xyz \approx yxz$	[111111,122255,122255,122255,122255,122355]	(6,6625)
	$xyz \approx x^2yz$	[111116,111116,111116,111416,112116,111116]	(6,3362)
		[111116,111116,111116,111446,112446,111116]	(6,6155)
		[111116,111116,111126,111416,112116,111116]	(6,3619)
		[111116,111116,111126,111446,111446,111116]	(6,5894)
		[111116,111116,111126,111446,112446,111116]	(6,6157)
		[111116,122226,122226,122226,122326,111116]	(6,4002)
		[111116,122226,122226,122236,122326,111116]	(6,4004)
		[111155,111155,111155,111455,111155,112155]	(6,6173)
		[111155,111155,111155,112155,111155,111156]	(6,3379)
		[111155,111155,111255,112155,111155,111156]	(6,3623)
		[111155,111155,113355,113355,111155,111255]	(6,9817)
		[111444,111444,111444,111444,111454,112444]	(6,6178)
	[111444,111444,111444,111444,111455,112455]	(6,6181)	
PB[6,030]	(A)	[111111,111111,111111,111416,112111,111614]	(6,2958)
	$x^2 \approx x^4$	[111111,111111,111111,111446,112446,111664]	(6,5770)
	$xy^2 \approx yxy$	[111111,111111,111111,111455,111544,112544]	(6,5772)
	$xyz \approx xzy$	[111111,111111,111112,111454,111545,111454]	(6,5770)
	(B)	[111111,111111,111112,111455,111544,111544]	(6,5772)
	$x^2 \approx x^4$	[111111,122226,122226,122226,122326,166662]	(6,1265)
	$x^2y \approx yx^2$	[111111,122444,122444,144222,144222,144232]	(6,1359)
	$xyz \approx x^3yz$	[111111,122444,122444,144222,144222,145222]	(6,1360)
		[111111,122444,122445,144222,144222,144222]	(6,1360)
		[111116,111116,111116,111416,112116,666661]	(6,1236)
		[111116,111116,111116,111446,112446,666661]	(6,3069)
		[111116,111116,111126,111446,111446,666661]	(6,3069)
		[111116,122226,122226,122226,122326,666661]	(6,3065)
		[111444,111444,113444,444111,444111,444121]	(6,1318)
		[111444,111444,113444,444111,444111,454111]	(6,1322)
		[111444,111445,113444,444111,444111,444111]	(6,1322)
		[111444,122444,122444,444111,444111,445111]	(6,3131)
		[111444,122444,122445,444111,444111,444111]	(6,3131)

Continued on next page

Table 9 – Continued from previous page

Id	Basis Proposal	Min.Lex	GAP
PB[6,031]	(A)	[111111,111111,111111,111416,112111,666666]	(6,3367)
	$x^2 \approx x^3$	[111111,111111,111111,111446,112446,666666]	(6,5921)
	$x^2y \approx xyx$	[111111,111111,111112,111451,555555,112111]	(6,3622)
	$xyz \approx x^2yz$	[111111,111111,111112,111454,555555,111454]	(6,6161)
	(B)	[111111,111111,111112,111454,555555,112454]	(6,6163)
	$x^2 \approx x^3$	[111111,111111,111112,111455,555555,555555]	(6,6174)
	$x^2y \approx xyx$	[111111,122226,122226,122226,122326,666666]	(6,4008)
	$xyz \approx x^2yz$	[111111,122226,122226,122236,122326,666666]	(6,4010)
PB[6,032]	(A)	[111111,111111,111111,111416,112121,111614]	(6,5398)
	$x^3 \approx x^5$	[111111,111111,111112,111451,111541,111112]	(6,5398)
	$xy^2 \approx yxy$	[111111,111111,112111,111416,112121,111614]	(6,9352)
	$xyz \approx xzy$	[111111,111111,112111,111446,112446,111664]	(6,5875)
	(B)	[111111,111111,112111,111455,111544,112544]	(6,5882)
	$x^2y \approx yx^2$	[111111,111111,112112,111454,111545,111454]	(6,5875)
	$xyz \approx x^3yz$	[111111,111111,112112,111455,111544,111544]	(6,5882)
		[111111,122226,122226,122226,122336,166662]	(6,2865)
		[111111,122226,122226,122236,122336,166662]	(6,2865)
		[111111,122226,122226,122326,122336,166662]	(6,5308)
		[111111,122444,122444,144222,144222,144233]	(6,2901)
		[111111,122444,122444,144222,144223,144223]	(6,2901)
		[111111,122444,122444,144222,144232,144233]	(6,5322)
		[111116,111116,111116,111416,112126,666661]	(6,2849)
		[111116,111116,111126,111416,111126,666661]	(6,2849)
		[111116,111116,112116,111416,112126,666661]	(6,5300)
		[111116,111116,112116,111446,112446,666661]	(6,5490)
		[111116,111116,112126,111446,111446,666661]	(6,5490)
		[111116,122226,122226,122226,122336,666661]	(6,5484)
		[111116,122226,122226,122236,122236,666661]	(6,5484)
		[111116,122226,122226,122326,122336,666661]	(6,9397)
		[111444,111444,113444,444111,444111,444122]	(6,2887)
	[111444,111444,113444,444111,444112,444112]	(6,2887)	
	[111444,111444,113444,444111,444121,444122]	(6,5314)	

Continued on next page

Table 9 – Continued from previous page

Id	Basis Proposal	Min.Lex	GAP
PB[6,033]	(A)	[111111,111111,111111,112111,121451,666666]	(6,3368)
	$x^2 \approx x^3$	[111111,111111,111111,112111,121455,121466]	(6,3370)
	$xyx \approx xy^2$	[111111,111111,111111,112111,122451,666666]	(6,3374)
	$xyzx \approx xzyx$	[111111,111111,111111,112111,122455,122466]	(6,3376)
	(B)	[111111,111111,111112,123411,555555,555555]	(6,6175)
	$x^2 \approx x^3$	[111111,111111,111112,123412,555555,555555]	(6,6176)
	$xyx \approx xy^2$		
	$xyz \approx x^2yz$ $xyzx \approx xzyx$		
PB[6,034]	(A)	[111111,111111,111111,112111,121456,121456]	(6,3371)
	$x^2 \approx x^3$	[111111,111111,111111,112111,122456,122456]	(6,3377)
	$xyx \approx yx^2$	[111116,111116,111116,112116,121456,111116]	(6,3810)
	$xyz \approx x^2yz$	[111116,111116,111116,112116,122456,111116]	(6,3823)
	$xy^2z \approx xyxz$	[111155,111155,111155,112155,111155,121456]	(6,3816)
	(B)	[111155,111155,111155,112155,111155,122456]	(6,3829)
	$x^2 \approx x^3$	[111155,111155,111155,113456,111155,131155]	(6,6433)
	$xyx \approx yx^2$	[111155,111155,111155,122456,111155,112155]	(6,6440)
	$xyz \approx x^2yz$	[111444,111444,111444,111444,112444,121456]	(6,6438)
	$xyxz \approx xy^2z$	[111444,111444,111444,111444,112444,122456]	(6,6445)
PB[6,035]	(A)	[111111,111111,111111,112111,121456,121465]	(6,2960)
	$x^2 \approx x^4$	[111111,111111,111111,112111,122456,122465]	(6,2962)
	$xyx \approx yx^2$	[111116,111116,111116,112116,121456,666661]	(6,1237)
	$xyz \approx x^3yz$	[111116,111116,111116,112116,122456,666661]	(6,1238)
	$xy^2x \approx x^2y^2$	[111444,111444,113456,444111,444111,454111]	(6,1323)
	(B)	[111444,111444,123446,444111,444111,444121]	(6,1319)
	$x^2 \approx x^4$	[111444,111445,123454,444111,444111,444111]	(6,1349)
	$xyx \approx yx^2$ $xyx \approx x^2y^3$ $xyz \approx x^3yz$	[111444,111445,123455,444111,444111,444111]	(6,1351)
PB[6,036]	(A)	[111111,111111,111111,112111,121456,122456]	(6,3372)
	$x^2 \approx x^3$		
	$xyx \approx yx^2$		
	$xyz \approx x^2yz$		
	$xyzx \approx xzyx$		
	(B)		
	$x^2 \approx x^3$		
	$xyx \approx yx^2$ $xyz \approx x^2yz$ $xyza \approx yxza$		

Continued on next page

Table 9 – Continued from previous page

Id	Basis Proposal	Min.Lex	GAP
PB[6,037]	(A) $x^2 \approx x^3$ $xyx \approx xy^2$ $x^2yx \approx xyx$ (B) $x^2 \approx x^3$ $xyx \approx xy^2$ $xyz \approx x^2yz$	[111111,111111,111111,112111,121456,666666] [111111,111111,111111,112111,122456,666666] [111111,111111,111112,123455,555555,555555]	(6,3373) (6,3378) (6,6177)
PB[6,038]	(A) $x^2 \approx x^3$ $xyx \approx xy^2x$ $x^2yx \approx x^2y^2$ $xyx^2 \approx x^2yx$ (B) $x^2 \approx x^3$ $xyz \approx xy^2z$ $x^2yx \approx x^2y^2$ $x^2yx \approx yxyx$	[111111,111111,111111,112115,112215,113316]	(6,1075)
PB[6,039]	(Known basis) $x^2 \approx x^3$ $xyx \approx xyz$	[111111,111111,111111,112115,555555,666666] [111111,111111,111112,444444,555555,111141] [111111,111111,111112,444444,555555,112141] [111111,111111,111112,444444,555555,444414] [111111,111111,111112,444444,555555,444555] [111111,111111,111114,444444,112114,666666] [111111,111111,111124,444444,112114,666666] [111111,111111,111124,444444,444441,666666] [111111,111111,111124,444444,444444,666666] [111111,111111,333333,333312,555555,555555]	(6,3393) (6,3557) (6,3625) (6,6172) (6,6180) (6,3558) (6,3626) (6,6187) (6,6188) (6,9884)
PB[6,040]	(A) $x^2y \approx x^3y$ $xyx \approx xy^2x$ $xy^2 \approx xy^3$ $x^2yx \approx x^2y^2$ (B) $xyz \approx xy^2z$ $x^2yx \approx x^2y^2$ $x^2yx \approx yxyx$	[111111,111111,111111,112124,112124,113136]	(6,2664)

Continued on next page

CHAPTER 3 - OPEN PROBLEMS

Table 9 – Continued from previous page

Id	Basis Proposal	Min.Lex	GAP
PB[6,041]	(A) $xy \approx x^2y$ $xyzx \approx xzyx$ (B) $xy \approx x^2y$ $xyzx \approx xzyx$	[111111,111111,111111,113416,555555,133416] [111111,111111,123116,444444,444444,123126]	(6,7184) (6,10475)
PB[6,042]	(A) $xy \approx x^2y$ $xyx^2 \approx xyx$ $xyxz^2 \approx xyz^2$ (B) $xy \approx x^2y$ $xyzx \approx yxzx$ $xyzx \approx xyzyx$	[111111,111111,111111,113456,133456,666666]	(6,7216)
PB[6,043]	(A) $xyz \approx xzy$ $xyx \approx y^2x$ $x^4 \approx yzab$ (B) $x^2y \approx yxy$ $xyz \approx xzy$ $x^4 \approx yzab$	[111111,111111,111112,111112,111213,111214] [111111,111111,111112,111112,111213,111224] [111111,111111,111112,111112,111223,111214] [111111,111111,111112,111112,111223,111224]	(6,871) (6,872) (6,2538) (6,2539)
PB[6,044]	(A) $x^2y \approx xy^2$ $xyz \approx yxz$ $x^4 \approx yzab$ (B) $x^2y \approx xy^2$ $xyz \approx yxz$ $x^4 \approx yzab$	[111111,111111,111112,111112,111234,111234]	(6,2558)
PB[6,045]	(A) $xy \approx yx$ $x^4 \approx y^3$ (B) $xy \approx yx$ $x^3 \approx yzab$	[111111,111111,111112,111121,111213,112134] [111111,111111,111112,111121,111223,112134]	(6,880) (6,2556)

Continued on next page

Table 9 – Continued from previous page

Id	Basis Proposal	Min.Lex	GAP
PB[6,046]	(A) $xy \approx yx$ $x^4 \approx yzab$	[111111,111111,111112,111121,111234,112143] [111111,111111,111112,111122,111213,112234] [111111,111111,111112,111122,111223,112234]	(6,2222) (6,881) (6,2557)
	(B) $xy \approx yx$ $x^4 \approx yzab$		
PB[6,047]	(A) $x^2 \approx y^2$ $xyx \approx yxy$	[111111,111111,111112,111121,112114,111231]	(6,141)
	(B) $x^2 \approx y^2$ $xyx \approx yxy$ $xyz \approx zyx$		
PB[6,048]	(A) $xyx \approx yxy$ $xy^2 \approx z^2a$	[111111,111111,111112,111121,112114,111232] [111111,111111,111112,111121,112124,111232]	(6,659) (6,1865)
	(B) $x^3 \approx y^2z$ $x^3 \approx yzab$ $xyx \approx yxy$ $xyz \approx zyx$		
PB[6,049]	(A) $xy \approx yx$ $x^3y^2 \approx x^4y$	[111111,111111,111112,111123,111234,112345]	(6,2582)
	(B) $xy \approx yx$ $x^2yza \approx xy^2za$ $x^6 \approx xyzabc$		
PB[6,050]	(A) $xyz \approx xzy$ $xyx \approx y^2x$	[111111,111111,111112,111141,111151,112113] [111111,111111,111112,111141,111151,112143] [111111,112222,113333,113333,113334,113345]	(6,2797) (6,2798) (6,5480)
	(B) $x^2y \approx yxy$ $xyz \approx xzy$ $xyza \approx xy^2za$		

Continued on next page

CHAPTER 3 - OPEN PROBLEMS

Table 9 – Continued from previous page

Id	Basis Proposal	Min.Lex	GAP
PB[6,051]	(A) $xy \approx yx$ $x^4y \approx x^3y$	[111111,111111,111112,111141,111451,112113] [111111,111111,111112,111141,111454,112143] [111111,112222,123333,123333,123334,123345]	(6,2802) (6,2803) (6,5487)
	(B) $xy \approx yx$ $x^2yz \approx x^3yz$		
PB[6,052]	(A) $x^2y \approx x^3y$ $xyx \approx yxy$	[111111,111111,111112,111141,123153,111112] [111111,111111,111112,111141,123153,111142]	(6,2675) (6,2677)
	(B) $x^2y \approx x^3y$ $xyx \approx yxy$ $xyx \approx x^2yx$ $xyza \approx xy^2za$		
PB[6,053]	(A) $x^2y \approx x^3y$ $xyx \approx yx^3$	[111111,111111,111112,111141,123453,111112] [111111,111111,111112,112142,123453,111112] [111111,111111,111113,111123,111123,123446]	(6,2676) (6,2702) (6,2680)
	(B) $x^2y \approx x^3y$ $xyx \approx xyx^2$ $xyxy \approx xy^2x$ $xyza \approx yxza$		
PB[6,054]	(A) $x^2 \approx x^3$ $xyx \approx x^2yx$ $x^2y^2 \approx xyx^2$	[111111,111111,111112,111144,123155,123155]	(6,2979)
	(B) $x^2 \approx x^3$ $xyx \approx x^2yx$ $x^2y^2 \approx xyx^2$ $x^2y^2 \approx yx^2y$ $xyza \approx xy^2za$		

Continued on next page

Table 9 – Continued from previous page

Id	Basis Proposal	Min.Lex	GAP
PB[6,055]	(A) $x^2 \approx x^3$ $xyx \approx x^2yx$ $x^2y^2 \approx xyxy$ $xy^2z \approx yxyz$ $xyzy \approx yxzy$ (B) $x^2 \approx x^3$ $xyx \approx x^2yx$ $x^2y^2 \approx xy^2x$ $xyza \approx yxza$	[111111,111111,111112,111144,123455,123455] [111111,111111,111112,112144,123455,123455] [111111,111122,111122,111123,123455,123455]	(6,2980) (6,2986) (6,3032)
PB[6,056]	(A) $xy \approx yx$ $x^2y^2 \approx x^3y$ (B) $xy \approx yx$ $x^2yz \approx xy^2z$ $xyzab \approx x^2yzab$	[111111,111111,111112,111213,111151,112314] [111111,122222,122222,122223,122234,122345]	(6,5368) (6,5371)
PB[6,057]	(A) $xyz \approx xzy$ $x^2y^2 \approx x^3y$ (B) $xyz \approx xzy$ $x^2yz \approx xy^2z$ $x^5 \approx xyzab$	[111111,111111,111112,111213,555555,112314]	(6,5369)
PB[6,058]	(A) $xy^2 \approx x^2y$ $xyz \approx xzy$ (B) $x^2y \approx xy^2$ $xyz \approx xzy$ $xyza \approx x^2yza$	[111111,111111,111112,111411,555555,112113] [111111,111111,111112,111441,111551,112113] [111111,111111,111112,444444,444454,112113] [111111,121222,333333,121222,121224,121245] [111111,122222,122222,122223,155555,122324]	(6,5680) (6,5682) (6,5684) (6,5724) (6,5714)
PB[6,059]	(A) $x^2y \approx xy^2$ $xyz \approx yxz$ (B) $x^2y \approx xy^2$ $xyz \approx yxz$ $xyza \approx x^2yza$	[111111,111111,111112,111451,111451,112113] [111111,122226,122226,122236,122346,122226] [111116,111116,111126,111416,112136,111116] [111116,122226,122226,122236,122346,111116] [111155,111155,111255,112355,111155,111156]	(6,5682) (6,5714) (6,5680) (6,5724) (6,5684)

Continued on next page

Table 9 – Continued from previous page

Id	Basis Proposal	Min.Lex	GAP
PB[6,060]	(A)	[111111,111111,111112,111451,111541,112111]	(6,3013)
	$x^2 \approx x^4$	[111111,111111,111112,111454,111545,112454]	(6,5790)
	$xy \approx yx$	[111111,111111,111112,111455,111544,112544]	(6,5791)
	$xy^3 \approx x^3y$	[111111,122226,122226,122236,122326,166662]	(6,1266)
		[111111,122444,122444,144222,144223,144232]	(6,1361)
		[111111,122444,122445,144222,144222,145222]	(6,1362)
		[111116,111116,111126,111416,112116,666661]	(6,1250)
		[111116,111116,111126,111446,112446,666661]	(6,3078)
		[111116,122226,122226,122236,122326,666661]	(6,3067)
		[111444,111444,113444,444111,444112,444121]	(6,1336)
		[111444,111445,113444,444111,444111,454111]	(6,1356)
	[111444,122444,122445,444111,444111,445111]	(6,3140)	
PB[6,061]	(A)	[111111,111111,111112,111451,111541,112113]	(6,5466)
	$xy \approx yx$	[111111,122226,122226,122236,122346,166662]	(6,2867)
	$x^4 \approx x^6$	[111111,122444,122445,144222,144222,145223]	(6,2903)
	$xy^3 \approx x^3y$	[111116,111116,111126,111416,112136,666661]	(6,2862)
		[111116,122226,122226,122236,122346,666661]	(6,5488)
	[111444,111445,113444,444111,444111,454112]	(6,2898)	
PB[6,062]	(A)	[111111,111111,111112,111451,555555,112113]	(6,5683)
	$x^2y \approx xyx$ $xy^2 \approx x^2y$	[111111,122226,122226,122236,122346,666666]	(6,5733)
PB[6,063]	(B)		
	$x^2y \approx xyx$ $x^2y \approx xy^2$ $xyz \approx x^2yza$		
	(A)	[111111,111111,111112,123413,555555,111112]	(6,5577)
	$x^2y \approx x^3y$ $xy^2 \approx x^2y^2$ $xyx \approx xy^3$ $xyzx \approx xzyx$	[111111,111111,111112,123443,123553,111112]	(6,5579)
	(B)		
	$xyx \approx xyxy$ $xyz \approx x^2yz$ $xyzx \approx xzyx$		
PB[6,064]	(A)	[111111,111111,111112,123414,555555,123414]	(6,6165)
	$x^2 \approx x^3$ $xyx \approx x^2yx$ $xy^2 \approx x^2y^2$ $xyz^2 \approx xzy^2$	[111111,111111,111112,123444,123555,123444]	(6,6167)

Continued on next page

Table 9 – Continued from previous page

Id	Basis Proposal	Min.Lex	GAP
PB[6,065]	(A) $x^2y \approx x^3y$ $xyx \approx x^2yx$ $xy^2 \approx yx^2$ (B) $xy^2 \approx yx^2$ $xyz \approx x^2yz$	[111111,111111,111112,123444,123444,123445]	(6,5854)
PB[6,066]	(A) $x^2y \approx x^3y$ $xy^2 \approx x^2y^2$ $xyx \approx yxyx$ $xy^2z \approx xyxz$ (B) $xyx \approx yx^3$ $xyz \approx x^2yz$ $xyxz \approx xy^2z$	[111111,111111,111112,123453,123453,111112] [111116,111116,111126,123436,111126,111116] [111155,111155,111255,111255,111155,123356]	(6,5580) (6,5635) (6,5637)
PB[6,067]	(A) $x^2y \approx x^4y$ $xy^2 \approx x^3y^2$ $xyx \approx y^2xyx$ $xyxy \approx xy^2x$	[111111,111111,111112,123453,123543,111112] [111116,111116,111126,123436,111126,666661] [111444,111444,123455,444111,444112,444112]	(6,5427) (6,2852) (6,2890)
PB[6,068]	(A) $x^2y \approx x^3y$ $xy^2 \approx x^2y^2$ $xyx \approx xy^3$ (B) $xyx \approx xyxy$ $xyz \approx x^2yz$	[111111,111111,111112,123453,555555,111112]	(6,5581)
PB[6,069]	(A) $x^2 \approx x^3$ $xyx \approx x^2yx$ $xy^2 \approx yxy^2$ $xy^2z \approx xyxz$ (B) $x^2 \approx x^3$ $xy^2 \approx yx^2y$ $xyz \approx x^2yz$ $xyxz \approx xy^2z$	[111111,111111,111112,123454,123454,123454] [111116,111116,111126,123446,123446,111116] [111155,111155,123356,123356,111155,111255]	(6,6169) (6,6510) (6,9924)

Continued on next page

Table 9 – Continued from previous page

Id	Basis Proposal	Min.Lex	GAP
PB[6,070]	(A) $x^2 \approx x^4$ $xyx \approx x^3yx$ $xy^2 \approx y^2xy^2$ $xyx^2 \approx xy^3$	[111111,111111,111112,123454,123545,123454] [111111,111111,111112,123455,123544,123544] [111116,111116,111126,123446,123446,666661] [111444,122456,122456,444111,444111,445111]	(6,5793) (6,5794) (6,3079) (6,3141)
	(B) $x^2 \approx x^4$ $xy^2 \approx x^2y^2x$ $xy^2 \approx yx^3y$ $xyz \approx x^3yz$		
PB[6,071]	(A) $x^2 \approx x^3$ $xyx \approx x^2yx$ $xyx^2 \approx xy^2$	[111111,111111,111112,123454,555555,123454]	(6,6171)
	(B) $x^2 \approx x^3$ $xy^2 \approx xyx^2$ $xyz \approx x^2yz$		
PB[6,072]	(A) $xyx \approx xy^2$ $x^4 \approx x^2yz$	[111111,111111,111112,444444,555555,112143]	(6,5686)
	(B) $xyx \approx xy^2$ $xyx^2 \approx xyza$		
PB[6,073]	(A) $xy^2 \approx xy^3$ $xyz \approx xzy$ $xyx \approx xyx^2$ $xy^2x \approx y^2x^2$	[111111,111111,111113,111114,111121,111416] [111111,111111,111113,111114,111121,113316] [111111,111111,111113,111114,111123,111416] [111111,111111,111113,111114,111123,113136] [111111,111111,111113,111114,111123,113336]	(6,2606) (6,2667) (6,2607) (6,2610) (6,2669)
	(B) $x^2y \approx x^3y$ $xy^2 \approx xy^3$ $xyz \approx xzy$ $x^2y^2 \approx yx^2y$	[111111,111111,111113,111114,111123,114446] [111111,111222,111333,113444,113444,113445] [111111,111222,111333,122444,122444,122445]	(6,2670) (6,5859) (6,5861)

Continued on next page

Table 9 – Continued from previous page

Id	Basis Proposal	Min.Lex	GAP
PB[6,074]	(A)	[111111,111111,111113,111114,111135,123156]	(6,2737)
	$x^3 \approx x^4$	[111111,111111,111113,111114,111135,123356]	(6,2738)
	$xyxz \approx x^2yz$	[111111,111111,111113,111334,111335,123446]	(6,5217)
	$xy^2x \approx x^2y^2$	[111111,111112,111112,111114,111125,123156]	(6,2738)
	$xyzx \approx xzyx$	[111111,111112,111112,111114,111125,123256]	(6,2750)
	$xy^2x \approx y^2x^2$	[111111,111112,111112,111224,111225,123446]	(6,5228)
		[111111,111112,111113,111224,111224,121456]	(6,5217)
		[111111,111112,111113,111224,111224,122456]	(6,5228)
	[111111,111112,112223,112223,112225,123436]	(6,9319)	
PB[6,075]	(A)	[111111,111111,111113,111114,111311,121116]	(6,1040)
	$x^2 \approx x^3$	[111111,111111,111113,111114,111311,121126]	(6,1098)
	$xyx \approx yxy$	[111111,111111,111113,111114,111313,121116]	(6,1042)
	$x^2y^2 \approx xyx$	[111111,111111,111113,111114,111313,121126]	(6,1099)
	$xyxz \approx x^2yz$		
	(B)		
	$x^2 \approx x^3$		
	$xyx \approx yxy$		
	$xyx \approx x^2yx$		
	$xyzza \approx xyz^2a$		
PB[6,076]	(A)	[111111,111111,111113,111114,111315,123456]	(6,1118)
	$x^2 \approx x^3$	[111111,111112,111112,111114,111215,123456]	(6,1170)
	$xyx \approx yx^2$	[111111,111112,111112,111114,144115,123456]	(6,1176)
	$xyxz \approx x^2yz$	[111111,111112,111113,112114,112114,123456]	(6,1193)
	$xy^2x \approx x^2y^2$		
	(B)		
	$x^2 \approx x^3$		
	$xyx \approx yx^2$		
	$x^2y^2 \approx xy^2x$		
	$x^2yz \approx xyxz$		
PB[6,077]	(A)	[111111,111111,111113,111114,111321,111116]	(6,2638)
	$x^2y \approx xyx$	[111111,111111,111113,111114,111323,111116]	(6,2639)
	$xyz \approx xyz^2$		
	$xyx \approx y^2x$		
	(B)		
	$x^2y \approx xyx$		
	$x^2y \approx yxy$		
	$xyz \approx xyz^2$		

Continued on next page

CHAPTER 3 - OPEN PROBLEMS

Table 9 – Continued from previous page

Id	Basis Proposal	Min.Lex	GAP
PB[6,078]	(A) $xyx \approx yxy$ $xy^2 \approx xy^3$	[111111,111111,111113,111114,111334,121116] [111111,111111,111113,111114,111334,121126]	(6,2675) (6,2677)
	(B) $xyx \approx yxy$ $xyx \approx x^2yx$ $xy^2 \approx xy^3$ $xyza \approx xyz^2a$		
PB[6,079]	(A) $xy^2 \approx xy^3$ $xyxz \approx x^2yz$ $xy^2x \approx x^2y^2$	[111111,111111,111113,111114,111335,121446] [111111,111112,111112,111114,144145,123126]	(6,2683) (6,2706)
	(B) $xy^2 \approx xy^3$ $xyza \approx xzya$ $x^3y^2 \approx yx^2y^2$ $x^2yzy \approx xy^2zx$		
PB[6,080]	(A) $x^3 \approx x^4$ $xyx \approx yx^2$ $xyxz \approx x^2yz$ $xy^2x \approx x^2y^2$	[111111,111111,111113,111114,111335,123456] [111111,111111,111113,111134,111135,123456] [111111,111111,111113,111134,111135,123456] [111111,111112,111112,111114,111225,123456] [111111,111112,111112,111114,144145,123456]	(6,2741) (6,2742) (6,5211) (6,2753) (6,2760)
	(B) $x^3 \approx x^4$ $xyx \approx yx^2$ $x^2y^2 \approx xy^2x$ $x^2yz \approx yxz$	[111111,111112,111112,111124,111125,123456] [111111,111112,111112,111214,111225,123456] [111111,111112,111113,112224,112224,123456] [111111,111112,111123,111123,111125,123456] [111111,111112,111223,111224,111224,123456] [111111,111112,112113,112224,112224,123456] [111111,111112,112123,112224,112123,123456]	(6,2754) (6,5222) (6,5247) (6,2764) (6,5248) (6,9306) (6,9307)
	(A) $x^2y \approx x^3y$ $x^2y^2 \approx xyxy$ $xyzx \approx xzyx$ $xy^2x \approx y^2x^2$	[111111,111111,111113,111124,111124,121456] [111111,111111,111123,111124,111123,123356]	(6,2683) (6,2706)

Continued on next page

Table 9 – Continued from previous page

Id	Basis Proposal	Min.Lex	GAP
PB[6,082]	(A)	[111111,111111,111113,111134,111345,123456]	(6,2808)
	$xyz \approx yxz$	[111111,111112,111112,111124,111245,123456]	(6,2810)
	$x^4 \approx x^5$	[111111,111112,111123,111123,112235,123456]	(6,2814)
	$xy^2x \approx x^2y^2$	[111111,111112,111223,112334,112334,123456]	(6,5269)
	(B)		
	$xyz \approx yxz$ $x^4 \approx x^5$ $x^2y^2 \approx xy^2x$ $x^2yzaz \approx xyz^2ax$		
PB[6,083]	(A)	[111111,111111,111113,111211,113151,111116]	(6,5547)
	$x^2y \approx x^3y$	[111111,111111,111113,111213,113351,111116]	(6,5557)
	$xyx \approx yxy$	[111111,111112,123331,123331,123341,111116]	(6,9631)
	$xy^2 \approx xy^3$	[111111,111222,123111,111444,111444,111445]	(6,9631)
	$x^2y^2 \approx xyx$		
PB[6,084]	(A)	[111111,111111,111113,111211,113153,111116]	(6,5548)
	$x^2y \approx x^3y$	[111111,111111,111113,111213,113353,111116]	(6,5558)
	$xyx \approx yxy$	[111111,111112,123332,123332,123342,111116]	(6,9632)
	$xy^2 \approx xy^3$	[111111,111222,123222,111444,111444,111445]	(6,9632)
	(B)		
	$x^2y \approx x^3y$		
	$xyx \approx yxy$ $xyx \approx x^2yx$ $xy^2 \approx xy^3$		
PB[6,085]	(A)	[111111,111111,111113,111211,113155,113156]	(6,5549)
	$x^2y \approx x^3y$	[111111,111111,111113,111213,113355,113356]	(6,5559)
	$xyx \approx yx^2$	[111111,111112,123333,123333,123343,123336]	(6,9618)
	$x^2yx \approx xyx$	[111111,111222,123333,123444,123444,123445]	(6,9656)
	$xy^2x \approx x^2y^2$		
	(B)		
	$x^2y \approx x^3y$		
	$xyx \approx yx^2$ $xyx \approx x^2yx$ $x^2y^2 \approx xy^2x$		

Continued on next page

Table 9 – Continued from previous page

Id	Basis Proposal	Min.Lex	GAP
PB[6,086]	(A)	[111111,111111,111113,111211,555555,111116]	(6,5550)
	$xy^2 \approx xy^3$	[111111,111111,111113,111211,555555,555556]	(6,5554)
	$xyz \approx xzy$	[111111,111111,111113,111213,555555,111116]	(6,5560)
	$xyx \approx xy^2x$	[111111,111111,111113,111213,555555,555556]	(6,5564)
	(B)	[111111,111111,111133,111211,111155,111166]	(6,5525)
	$xyz \approx xzy$	[111111,111111,111133,111233,111155,111166]	(6,5531)
	$xyz \approx xy^2z$	[111111,111111,112111,111411,555555,555655]	(6,9544)
		[111111,111111,112111,444444,444445,444446]	(6,9547)
		[111111,111222,333333,111444,111444,111445]	(6,9633)
		[111111,111222,333333,333444,333444,333445]	(6,9662)
	[111111,112222,113333,113333,113343,116666]	(6,9619)	
PB[6,087]	(A)	[111111,111111,111113,111211,555555,111156]	(6,5551)
	$x^2y \approx xyx$	[111111,111111,111113,111213,555555,111156]	(6,5561)
	$xyz \approx xyz^2$	[111111,111111,112111,111455,555555,555655]	(6,9545)
	(B)	[111111,111222,333333,113444,113444,113445]	(6,9638)
	$x^2y \approx xyx$ $xyz \approx xy^2z$		
PB[6,088]	(A)	[111111,111111,111113,111211,555555,113116]	(6,5552)
	$xy^2 \approx xy^3$	[111111,111111,111113,111213,555555,113316]	(6,5562)
	$xyz \approx xzy$	[111111,111111,111133,111211,113155,113166]	(6,5570)
	$xyx \approx xyx^2$	[111111,111111,111133,111233,113355,113366]	(6,5572)
	(B)	[111111,111111,112111,444444,444445,444456]	(6,9548)
	$x^2y \approx x^3y$	[111111,111222,333333,121444,121444,121445]	(6,9653)
	$xy^2 \approx xy^3$ $xyz \approx xzy$	[111111,112222,123333,123333,123343,126666]	(6,9647)
PB[6,089]	(A)	[111111,111111,111113,111211,555555,113156]	(6,5553)
	$x^2y \approx xyx$	[111111,111111,111113,111213,555555,113356]	(6,5563)
	$xy^2 \approx xy^3$	[111111,111111,112111,111456,555555,555655]	(6,9546)
	$xyx \approx xyx^2$	[111111,111222,333333,123444,123444,123445]	(6,9657)
	(B)		
	$x^2y \approx xyx$ $x^2y \approx x^3y$ $xy^2 \approx xy^3$		

Continued on next page

Table 9 – Continued from previous page

Id	Basis Proposal	Min.Lex	GAP
PB[6,090]	(A) $x^3 \approx x^4$ $xyz \approx x^2yz$ $xy^2x \approx x^2y^2$ $xyzx \approx xzyx$ (B) $x^3 \approx x^4$ $x^2yx \approx x^3yx$ $x^2y^2 \approx xy^2x$ $xyza \approx xzya$ $x^2yzy \approx xy^2zx$	[111111,111111,111113,111314,555555,123416] [111111,111111,111133,111344,123455,123466] [111111,111112,111112,111214,555555,123416] [111111,111112,112123,444444,112123,123156] [111111,111122,111122,111244,123455,123466] [111111,111122,112233,112233,123455,123466]	(6,5613) (6,5659) (6,5621) (6,9450) (6,5668) (6,9466)
PB[6,091]	(Known basis) Lee and Zhang [48, Proposition 11.1]	[111111,111111,111113,111314,555555,123456] [111111,111111,123456,444444,445444,446445] [111111,111112,111112,111214,555555,123456] [111111,111112,112123,444444,112123,123456] Note: Lee and Zhang [48]	(6,5614) (6,9582) (6,5622) (6,9451)
PB[6,092]	(A) $x^2 \approx x^3$ $xyx \approx xy^2$ $xyz \approx xyz$ (B) $x^2 \approx x^3$ $xyx \approx xy^2$ $xyz \approx xyz$ $x^2yzx \approx x^2zyx$	[111111,111111,111114,444444,121151,666666] [111111,111111,111114,444444,122151,666666] [111111,111111,123111,444444,444441,666666] [111111,111111,123111,444444,444666,666666] [111111,111111,123112,444444,555555,444414] [111111,111111,123112,444444,555555,444555] [111111,111111,123113,444444,555555,123143] [111111,111111,123333,123335,125555,126666]	(6,7541) (6,7542) (6,10417) (6,10646) (6,10418) (6,10647) (6,10244) (6,10298)
PB[6,093]	(A) $x^2y \approx x^3y$ $xyx \approx x^2yx$ $xy^2 \approx x^2y^2$ $xyx^2 \approx xyxy$	[111111,111111,111122,123434,111122,123434]	(6,5441)
PB[6,094]	(A) $x^2y \approx x^3y$ $x^2yx \approx xyx^2$ $xyxy \approx yx^2y$ (B) $x^2y \approx x^3y$ $x^2yx \approx xyx^2$ $xyxz \approx yx^2z$ $x^2y^2x \approx x^2y^3$	[111111,111111,111123,123434,111123,123456]	(6,5595)

Continued on next page

CHAPTER 3 - OPEN PROBLEMS

Table 9 – Continued from previous page

Id	Basis Proposal	Min.Lex	GAP
PB[6,095]	(A) $x^2 \approx x^3$ $xyx \approx x^2yx$ $x^2y^2 \approx xyxy$ $xy^2z \approx yxyz$ (B) $x^2 \approx x^3$ $xyx \approx x^2yx$ $x^2y^2 \approx xy^2x$ $xyxz \approx yx^2z$	[111111,111111,111123,123444,123444,123456]	(6,6183)
PB[6,096]	(A) $x^2y \approx x^3y$ $x^2y^2 \approx xyxy$ $xyzx \approx xzyx$ (B) $x^2y \approx x^3y$ $xyza \approx xzya$ $x^2y^2x \approx x^2y^3$	[111111,111111,111123,444444,111123,123156] [111111,111111,111233,111233,123455,123466]	(6,5596) (6,5603)
PB[6,097]	(Known basis) Lee and Zhang [48, Proposition 12.1]	[111111,111111,111123,444444,111123,123456] Note: Lee and Zhang [48]	(6,5597)
PB[6,098]	(A) $x^2y \approx x^3y$ $xyxy \approx yx^2y$ $xyzx \approx xzyx$	[111111,111111,111124,112124,111124,125456]	(6,2708)
PB[6,099]	(A) $x^2 \approx x^3$ $xyx \approx xyx^2$ $x^2yx \approx x^2y^2$ $xyxy \approx x^2yx$ (B) $x^2 \approx x^3$ $xyx \approx xyx^2$ $x^2yx \approx yx^2y$ $xyza \approx xyz^2a$	[111111,111111,111133,111144,121155,121355]	(6,2979)

Continued on next page

Table 9 – Continued from previous page

Id	Basis Proposal	Min.Lex	GAP
PB[6,100]	(A)	[111111,111111,111133,111144,121456,121465]	(6,3001)
	$x^2 \approx x^4$	[111111,111111,111133,111144,123356,123365]	(6,3003)
	$xyx \approx x^3yx$	[111111,111122,111122,111144,123156,123165]	(6,3003)
	$xyxz \approx x^2yz$	[111111,111122,111122,111144,123256,123265]	(6,3037)
	$xy^2x \approx x^2y^2$	[111116,111116,111136,111146,121456,666661]	(6,1247)
	$xyzx \approx xzyx$	[111116,111116,111136,111146,123356,666661]	(6,1248)
	$xy^2x \approx y^2x^2$	[111116,111126,111126,111146,123156,666661]	(6,1248)
	(B)	[111116,111126,111126,111146,123256,666661]	(6,1256)
	$x^2 \approx x^4$	[111155,111155,111355,121456,555511,555611]	(6,1289)
	$xyx \approx x^3yx$	[111155,111155,111355,123455,555511,555611]	(6,1290)
	$xyza \approx xzya$	[111155,111255,111255,123455,555511,555611]	(6,1297)
	$x^2yza^2 \approx azaxayax$	[111155,111255,111355,113456,555511,555511]	(6,1290)
		[111155,111255,111355,122456,555511,555511]	(6,1297)
		[111444,111444,123446,444111,445111,446111]	(6,1333)
		[111444,111444,123455,444111,445111,446111]	(6,1334)
		[111444,112444,113456,444111,444111,446111]	(6,1333)
		[111444,112444,113456,444111,445111,445111]	(6,1334)
		[111444,112444,123446,444111,445111,444111]	(6,1342)
		[113333,123356,331111,341111,331111,361111]	(6,1387)
		[113333,123356,331111,341111,351111,351111]	(6,1388)
	[113333,123446,331111,341111,351111,331111]	(6,1388)	
	[113333,123446,331111,341111,351111,341111]	(6,1395)	
PB[6,101]	(A)	[111111,111111,111133,111144,123456,124365]	(6,3006)
	$x^2 \approx x^4$	[111111,111111,111134,111143,123456,123465]	(6,3008)
	$xyx \approx x^3yx$	[111111,111123,111132,111123,123456,123465]	(6,3040)
	$xy^2x \approx x^2y^2$		
	$xy^2z \approx y^2xz$		
PB[6,102]	(A)	[111111,111111,111133,111211,111155,113156]	(6,5549)
	$x^2y \approx xyx$	[111111,111111,111133,111233,111155,113356]	(6,5559)
	$xy^2 \approx xy^3$	[111111,112222,113333,113333,113343,123336]	(6,9618)
	$xyx \approx xyx^2$	[111111,112222,113333,123444,123444,123445]	(6,9656)
	$xy^2x \approx y^2x^2$		
	(B)		
	$x^2y \approx xyx$		
$x^2y \approx x^3y$			
$xy^2 \approx xy^3$			
$x^2y^2 \approx yx^2y$			

Continued on next page

Table 9 – Continued from previous page

Id	Basis Proposal	Min.Lex	GAP
PB[6,103]	(A)	[111111,111111,111133,111211,111156,111156]	(6,5524)
	$x^2y \approx yxy$	[111111,111111,111133,111233,111156,111156]	(6,5530)
	$xy^2 \approx xy^3$	[111111,112222,113336,113336,113346,113336]	(6,9639)
	$x^2y^2 \approx x^2y$	[111116,111116,111136,111216,111156,111116]	(6,5522)
	$xyxz \approx x^2yz$	[111116,111116,111136,111236,111156,111116]	(6,5528)
	(B)	[111116,112226,113336,113336,113346,111116]	(6,9642)
	$x^2y \approx yxy$	[111444,111444,112444,111444,111445,111446]	(6,9541)
	$xyz \approx xy^2z$ $x^2yz \approx xyxz$	[111444,111444,112445,111444,111445,111446]	(6,9542)
PB[6,104]	(A)	[111111,111111,111133,111211,111156,111165]	(6,5380)
	$xy^2 \approx xy^4$	[111111,111111,111133,111233,111156,111165]	(6,5382)
	$xyz \approx xzy$	[111111,112222,113336,113336,113346,116663]	(6,5498)
	$xyx \approx y^3x^2$	[111111,112222,113355,113355,115533,115534]	(6,5509)
		[111116,111116,111136,111216,111156,666661]	(6,2847)
		[111116,111116,111136,111236,111156,666661]	(6,2848)
		[111116,112226,113336,113336,113346,666661]	(6,5872)
		[111155,111155,111355,111455,555511,555512]	(6,2869)
		[111155,111155,112155,111455,555511,555611]	(6,2878)
		[111155,122255,122255,122355,555511,566611]	(6,5879)
		[111444,111444,113444,444111,444121,446111]	(6,2885)
	[111444,111444,113444,444111,445111,445112]	(6,2886)	
PB[6,105]	(A)	[111111,111111,111133,111211,113156,113156]	(6,5570)
	$x^2y \approx x^3y$	[111111,111111,111133,111233,113356,113356]	(6,5572)
	$xyz \approx yxz$	[111111,112222,123336,123336,123346,123336]	(6,9647)
	$x^2yx \approx xyx$	[111116,111116,111136,111216,113156,111116]	(6,5552)
	(B)	[111116,111116,111136,111236,113356,111116]	(6,5562)
	$x^2y \approx x^3y$	[111116,112226,123336,123336,123346,111116]	(6,9653)
	$xyx \approx x^2yx$	[111444,111444,112444,111444,111445,111456]	(6,9548)
	$xyz \approx yxz$		

Continued on next page

Table 9 – Continued from previous page

Id	Basis Proposal	Min.Lex	GAP
PB[6,106]	(A)	[111111,111111,111133,111211,113156,113165]	(6,5422)
	$xy \approx yx$	[111111,111111,111133,111233,113356,113365]	(6,5425)
	$x^4y \approx x^2y$	[111111,112222,123336,123336,123346,126663]	(6,5499)
	(B)	[111111,112222,123355,123355,125533,125534]	(6,5510)
	$xy \approx yx$	[111116,111116,111136,111216,113156,666661]	(6,2850)
	$x^2y \approx x^4y$	[111116,111116,111136,111236,113356,666661]	(6,2851)
		[111116,112226,123336,123336,123346,666661]	(6,5873)
		[111155,111155,111355,113455,555511,555512]	(6,2870)
		[111155,111155,112155,111456,555511,555611]	(6,2879)
		[111155,122256,122256,122356,555511,566611]	(6,5880)
	[111444,111444,113446,444111,444121,446111]	(6,2888)	
	[111444,111444,113455,444111,445111,445112]	(6,2889)	
PB[6,107]	(A)	[111111,111111,111133,111213,111155,111166]	(6,5526)
	$x^2y \approx xyx$		
	$xyz \approx xyz^2$		
	$x^2yz \approx x^2zy$		
	(B)		
$x^2y \approx xyx$			
$xyz \approx xy^2z$			
$x^2yz \approx x^2zy$			
PB[6,108]	(A)	[111111,111111,111133,111344,123456,123465]	(6,5453)
	$x^3 \approx x^5$	[111111,111122,111122,111244,123456,123465]	(6,5457)
	$xyz \approx yxz$	[111111,111122,112233,112233,123456,123465]	(6,9383)
	$xy^2x \approx x^2y^2$	[111116,111116,111136,111346,123456,666661]	(6,2856)
	(B)	[111116,111126,111126,111246,123456,666661]	(6,2858)
	$x^3 \approx x^5$	[111116,111126,112236,112236,123456,666661]	(6,5305)
	$xyz \approx yxz$	[111155,111155,111355,123456,555511,555613]	(6,2872)
	$x^2y^2 \approx xy^2x$	[111155,111255,111255,123456,555511,555612]	(6,2874)
	$x^2yzay \approx xy^2zax$	[111155,111255,112355,123456,555511,555511]	(6,2881)
	$x^2yzaz \approx xyz^2ax$	[111444,112444,123456,444111,444111,446112]	(6,2894)
	[111444,112444,123456,444111,445122,445122]	(6,5319)	

Continued on next page

Table 9 – Continued from previous page

Id	Basis Proposal	Min.Lex	GAP	
PB[6,109]	(A)	[111111,111111,111133,444444,111155,123156]	(6,7628)	
	$x^2 \approx x^3$	[111111,111111,111133,444444,121155,123156]	(6,7653)	
	$xyx \approx x^2yx$	[111111,111111,111333,111444,111555,123446]	(6,7682)	
	$xyxz \approx x^2yz$	[111111,111111,111333,111444,123455,123466]	(6,7688)	
	$xy^2x \approx x^2y^2$	[111111,111111,111333,121444,121555,123446]	(6,7715)	
	$xyz^2y \approx xz^2y^2$	[111111,111111,111333,121444,123455,123466]	(6,7718)	
	(B)	[111111,111122,111122,444444,111155,123156]	(6,8332)	
	$x^2 \approx x^3$	[111111,111222,111222,111444,111555,123446]	(6,8029)	
	$xyx \approx x^2yx$	[111111,111222,111222,111444,123455,123466]	(6,8415)	
	$x^2y^2 \approx xy^2x$	[111111,111222,333333,111444,111444,121456]	(6,11425)	
	$x^2yz \approx xyxz$	[111111,112222,113333,113333,115555,123436]	(6,10934)	
	$xy^2z^2 \approx xzy^2z$	[111111,112222,113333,113333,123455,123466]	(6,11222)	
	PB[6,110]	(A)	[111111,111111,111133,444444,121156,121156]	(6,7655)
		$x^2 \approx x^3$	[111111,111111,123116,444444,445445,123116]	(6,10616)
$xyx \approx x^2yx$		[111116,111116,111336,121446,121556,111116]	(6,7655)	
$xyx \approx xy^2x$		[111155,112255,113356,114456,111155,111155]	(6,10616)	
$xyxz \approx x^2yz$				
$xyzx \approx xzyx$				
(B)				
$x^2 \approx x^3$				
$xyx \approx x^2yx$				
$xyz \approx xy^2z$				
$x^2yz \approx xyxz$				
$xyzy \approx xzy^2$				
PB[6,111]	(A)	[111111,111111,111133,444444,121156,121165]	(6,6222)	
	$x^2 \approx x^4$	[111111,111111,123116,444444,445445,126113]	(6,9873)	
	$xyx \approx x^3yx$	[111116,111116,111336,121446,121556,666661]	(6,4058)	
	$xyx \approx xy^3x$	[111155,111155,123355,124455,555511,556611]	(6,4162)	
	$xyxz \approx x^2yz$	[111155,112255,113356,114456,555511,555511]	(6,4164)	
	$xy^2x \approx x^2y^2$	[111444,122446,133446,444111,455111,444111]	(6,4270)	
	$xyzx \approx xzyx$			
	(B)			
	$x^2 \approx x^4$			
	$xyx \approx x^2y^3$			
$xyz \approx xy^3z$				
$xyzy \approx xzy^2$				

Continued on next page

Table 9 – Continued from previous page

Id	Basis Proposal	Min.Lex	GAP
PB[6,112]	(A) $x^2 \approx x^3$ $xyx \approx x^2yx$ $xyx \approx xy^2x$ $xyxz \approx x^2yz$ (B) $x^2 \approx x^3$ $xyx \approx x^2yx$ $xyz \approx xy^2z$ $x^2yz \approx xyxz$	[111111,111111,111133,444444,121456,121456] [111111,111111,123446,444444,445445,123446]	(6,7659) (6,10620)
PB[6,113]	(A) $x^2 \approx x^4$ $xyx \approx x^3yx$ $xyx \approx xy^3x$ $xyxz \approx x^2yz$ $xy^2x \approx x^2y^2$	[111111,111111,111133,444444,121456,121465] [111111,111111,123446,444444,445445,126443]	(6,6225) (6,9878)
PB[6,114]	(A) $x^2 \approx x^4$ $xyx \approx x^3yx$ $xyxz \approx x^2yz$ $xy^2x \approx x^2y^2$ $xyzx \approx xzyx$ (B) $x^2 \approx x^4$ $xyx \approx x^3yx$ $x^2y^2 \approx xy^2x$ $xyza \approx xzya$	[111111,111111,111133,444444,123156,123165] [111111,111122,111122,444444,123156,123165] [111116,111116,111336,123446,123556,666661] [111116,111226,111226,123446,123556,666661] [111155,111155,123356,124456,555511,556611] [111155,112255,123356,124456,555511,555511] [111444,122456,133456,444111,444111,466111] [111444,122456,133456,444111,455111,455111]	(6,6234) (6,6502) (6,4061) (6,4096) (6,4166) (6,4205) (6,4273) (6,4302)
PB[6,115]	(A) $x^2 \approx x^4$ $xyx \approx x^3yx$ $xyxz \approx x^2yz$ $xy^2x \approx x^2y^2$ (B) $x^2 \approx x^4$ $xyx \approx x^3yx$ $x^2y^2 \approx xy^2x$ $x^2yz \approx xyxz$	[111111,111111,111133,444444,123456,123465] [111111,111111,123456,124356,555555,556655] [111111,111122,111122,444444,123456,123465]	(6,6239) (6,9880) (6,6506)

Continued on next page

CHAPTER 3 - OPEN PROBLEMS

Table 9 – Continued from previous page

Id	Basis Proposal	Min.Lex	GAP
PB[6,116]	(A)	[111111,111111,111134,444444,121156,666666]	(6,7675)
	$x^2 \approx x^3$	[111111,111111,123116,444444,445441,666666]	(6,10425)
	$xyx \approx xyx^2$	[111111,111111,123444,444444,445666,666666]	(6,10644)
	$x^2yx \approx x^2y^2$	[111111,111111,123444,444444,555555,556444]	(6,10642)
	$xy^2z \approx xyz$		
	(B)		
	$x^2 \approx x^3$		
	$xyx \approx xyxy$		
	$xyz \approx xy^2z$		
PB[6,117]	(A)	[111111,111111,111134,444444,123456,666666]	(6,7676)
	$x^2 \approx x^3$	[111111,111111,123456,444444,445441,666666]	(6,10426)
	$xyx \approx xyx^2$	[111111,111111,123456,444444,445666,666666]	(6,10643)
	$xyxy \approx xy^2x$	[111111,111123,333333,111123,123456,666666]	(6,8500)
	$x^2yxz \approx x^2yz$		
PB[6,118]	(A)	[111111,111111,111233,111233,123456,123456]	(6,5604)
	$x^2y \approx x^3y$	[111116,111116,111236,111236,123456,111116]	(6,5640)
	$xyz \approx yxz$	[111444,111444,112445,111444,112445,123456]	(6,9589)
PB[6,119]	(A)	[111111,111111,111233,111233,123456,123465]	(6,5449)
	$x^2y \approx x^4y$	[111116,111116,111236,111236,123456,666661]	(6,2854)
	$xyz \approx yxz$	[111444,111444,123456,444111,445112,445112]	(6,2892)
	(B)		
	$x^2y \approx x^4y$		
	$xyz \approx yxz$		
	$x^2y^2x \approx x^3y^4$		

Continued on next page

Table 9 – Continued from previous page

Id	Basis Proposal	Min.Lex	GAP
PB[6,120]	(A)	[111111,111111,111333,111444,123456,123465]	(6,6282)
	$x^2 \approx x^4$	[111111,111111,111333,111446,123456,111664]	(6,6246)
	$xyx \approx x^3yx$	[111111,111111,111333,121444,123456,123465]	(6,6284)
	$xyxz \approx x^2yz$	[111111,111111,111333,121446,123456,121664]	(6,6269)
	$xy^2x \approx x^2y^2$	[111111,111222,111222,111444,123456,123465]	(6,6524)
	$xy^2x \approx y^2x^2$	[111111,111222,111222,111446,123456,111664]	(6,6385)
	(B)	[111111,112222,113333,113333,123456,123465]	(6,9915)
	$x^2 \approx x^4$	[111111,112222,113336,113336,123456,116663]	(6,6858)
	$xyx \approx x^3yx$	[111111,112222,113355,123456,115533,115533]	(6,7001)
	$x^2y^2 \approx xy^2x$	[111116,111116,111336,111446,123456,666661]	(6,4053)
	$x^2y^2 \approx yx^2y$	[111116,111116,111336,121446,123456,666661]	(6,4059)
	$x^2yz \approx xyxz$	[111116,111226,111226,111446,123456,666661]	(6,4079)
		[111116,112226,113336,113336,123456,666661]	(6,6806)
		[111155,111155,113355,123456,555511,556611]	(6,4157)
		[111155,111155,123355,123456,555511,556611]	(6,4163)
		[111155,112255,113355,123456,555511,555511]	(6,4189)
		[111155,112255,113356,123456,555511,555511]	(6,4198)
		[111155,122255,122255,123456,555511,566611]	(6,6950)
		[111444,122444,123456,444111,444111,466111]	(6,4265)
		[111444,122444,123456,444111,455111,455111]	(6,4288)
	[111444,122446,123456,444111,455111,444111]	(6,4271)	
PB[6,121]	(A)	[111111,111111,111333,121456,121564,121645]	(6,9095)
	$x^2 \approx x^5$	[111156,111156,111356,121456,555561,666615]	(6,9105)
	$xyx \approx y^4x^2$	[111446,111446,123446,444661,445661,666114]	(6,14976)
	$xyxz \approx x^2yz$	[111446,112446,113456,444661,444661,666114]	(6,14976)
	$xy^2x \approx x^2y^2$	[113336,123356,336661,346661,336661,661113]	(6,15941)
		[113355,123356,335511,345511,551133,551133]	(6,15951)
PB[6,122]	(A)	[111111,111111,111333,123456,123564,123645]	(6,9096)
	$x^2 \approx x^5$	[111111,111222,111222,123456,123564,123645]	(6,9098)
	$xyz \approx yxz$	[111156,111156,111356,123456,555561,666615]	(6,9106)
	$xy^2x \approx x^2y^2$	[111156,111256,111256,123456,555561,666615]	(6,9108)
		[111446,111446,123456,444661,445661,666114]	(6,14978)
		[111446,112446,123456,444661,444661,666114]	(6,14980)
		[113336,123456,336661,336661,356661,661113]	(6,15942)
		[113336,123456,336661,346661,346661,661113]	(6,15944)
		[113355,123456,335511,335511,551133,561133]	(6,15952)

Continued on next page

CHAPTER 3 - OPEN PROBLEMS

Table 9 – Continued from previous page

Id	Basis Proposal	Min.Lex	GAP
PB[6,123]	(A)	[111111,111111,112111,111416,555555,111416]	(6,9677)
	$xyxz \approx xyz$	[111111,111111,112111,444444,444456,444456]	(6,9696)
	$xyzy \approx xzy$	[111111,121226,333333,121226,121246,121226]	(6,9776)
		[111116,111116,112116,111446,111556,111116]	(6,9677)
		[111116,122226,122226,122326,155556,111116]	(6,9776)
		[111444,111444,112444,111444,111455,111466]	(6,9696)
PB[6,124]	(A)	[111111,111111,112111,111416,555555,111614]	(6,9531)
	$xy^2 \approx x^3y^2$	[111111,111111,112111,444444,444456,444465]	(6,9551)
	$xyz \approx xzy$	[111111,121226,333333,121226,121246,161662]	(6,5744)
	$xyx \approx xy^3x$	[111111,121255,333333,121255,151522,151524]	(6,5758)
	(B)	[111116,111116,112116,111446,111556,666661]	(6,5736)
	$xyz \approx xzy$	[111116,122226,122226,122326,155556,666661]	(6,9649)
	$xyz \approx x^3yz$	[111155,111155,113355,114455,555511,555512]	(6,5750)
PB[6,125]	(A)	[111111,111111,112111,111456,111456,666666]	(6,9689)
	$x^2y \approx xy^2$	[111111,122256,122256,122356,122256,666666]	(6,9777)
	$xyxz \approx xyz$		
	(B)		
	$x^2y \approx xy^2$		
	$xyz \approx xyxz$		
PB[6,126]	(A)	[111111,111111,112111,111456,111546,666666]	(6,9534)
	$x^2y \approx xyx$	[111111,122256,122256,122356,155526,666666]	(6,5746)
	$xyz \approx x^3yz$	[111111,122446,122446,144226,144236,666666]	(6,5760)
PB[6,127]	(A)	[111111,111111,112111,111456,111564,111645]	(6,9800)
	$xy \approx yx$	[111111,122256,122256,122356,155562,166625]	(6,9804)
	$x^3 \approx x^6$	[111111,123355,135522,135522,152233,152234]	(6,15954)
	$xy^4 \approx x^4y$	[111156,111156,112156,111456,555561,666615]	(6,9802)
	(B)	[111156,122256,122256,122356,555561,666615]	(6,9805)
	$xy \approx yx$	[113355,123355,335511,335511,551133,551134]	(6,15955)
	$xyz \approx x^4yz$		
PB[6,128]	(A)	[111111,111111,112111,111456,555555,555614]	(6,9535)
	$x^2y \approx x^4y$	[111111,122256,122256,122356,555555,566612]	(6,5747)
	$xyx \approx x^3yx$	[111111,122446,122446,644221,644231,666666]	(6,5761)
	$xy^2 \approx x^3y^2$		
	$xyx^2 \approx x^3y$		
	(B)		
$x^2y \approx x^2yx^2$			
	$xyz \approx x^3yz$		

Continued on next page

Table 9 – Continued from previous page

Id	Basis Proposal	Min.Lex	GAP
PB[6,129]	(A)	[111111,111111,112114,444444,111151,666666]	(6,9699)
	$x^2y \approx x^3y$	[111111,111111,112114,444444,444454,666666]	(6,9700)
	$xyx \approx xy^2$	[111111,111111,112144,444444,555555,555556]	(6,9702)
	$xy^2 \approx xy^3$	[111111,121122,333333,444444,121122,121325]	(6,9787)
	$x^2yx \approx x^2y$	[111111,122222,122222,122325,155555,166666]	(6,9753)
PB[6,130]	(A)	[111111,111111,113136,444444,113456,113166]	(6,12178)
	$xy \approx x^2y$	[111111,111111,113356,113456,113556,666666]	(6,12315)
	$xy \approx xy^2$	[111111,111111,113456,444444,445456,446456]	(6,12351)
	$xyxzx \approx xyzx$	[111111,121226,333333,121226,123256,121266]	(6,14203)
	(B)	[111111,121226,333333,123446,123446,121666]	(6,14594)
	$xy \approx x^2y$	[111111,122256,122256,122456,122556,666666]	(6,14204)
	$xy \approx xy^2$	[111111,122256,123356,123356,125556,666666]	(6,14604)
	$xyxz \approx xyzxz$	[111116,111116,113336,113456,115556,111616]	(6,12178)
		[111116,111116,113336,113456,115556,116666]	(6,12315)
		[111116,122226,122226,122456,155556,111616]	(6,14203)
		[111116,122226,122226,122456,155556,166666]	(6,14204)
		[111116,122226,123356,123356,155556,116616]	(6,14594)
		[111116,122226,123356,123356,155556,166666]	(6,14604)
		[111155,111155,113456,444466,115155,446466]	(6,14052)
		[111155,122255,123455,144455,115155,115155]	(6,12351)
	[111155,122456,122456,444466,155155,466466]	(6,14607)	
PB[6,131]	(A)	[111111,111111,113136,444444,123456,113166]	(6,12185)
	$xy \approx x^2y$	[111111,111111,113356,123456,113556,666666]	(6,12324)
	$xyx^2 \approx xyx$	[111111,111111,123136,444444,123456,123166]	(6,12392)
	$xyxzx \approx xyzx$	[111111,111111,123356,123456,123556,666666]	(6,12462)
	(B)	[111111,111111,123456,444444,445456,446456]	(6,12492)
	$xy \approx x^2y$	[111111,121226,333333,121226,123456,121266]	(6,14252)
	$xyx \approx xyx^2$	[111111,122256,122256,123456,122556,666666]	(6,14253)
	$xyzx \approx xyzxz$	[111116,111116,113336,114446,123456,111166]	(6,12774)
		[111116,111116,113336,114446,123456,116666]	(6,12885)
		[111116,111116,123336,123456,125556,111616]	(6,13664)
		[111116,111116,123336,123456,125556,116666]	(6,13685)
		[111116,122226,122226,123456,155556,111616]	(6,14222)
		[111116,122226,122226,123456,155556,166666]	(6,14223)
		[111155,111155,123456,444466,115155,446466]	(6,14080)
		[111155,122255,123456,144455,115155,115155]	(6,13136)
	[111155,122256,123456,144456,115155,115155]	(6,13698)	

Continued on next page

Table 9 – Continued from previous page

<b>Id</b>	<b>Basis Proposal</b>	<b>Min.Lex</b>	<b>GAP</b>
PB[6,132]	(Known basis) Lee and Zhang [48, Proposition 13.1]	[111111,111111,113156,121411,555555,556513]	(6,10203)
		[111111,111111,113333,114444,123456,124365]	(6,10409)
		[111111,111111,113356,123456,555555,556613]	(6,10218)
		[111111,111111,123333,123456,125555,125634]	(6,10410)
		[111111,111111,123456,124365,555555,666666]	(6,10411)
		[111111,111111,123456,444444,444444,456123]	(6,9882)
		[111111,122256,122256,123456,555555,566612]	(6,8921)
		[111111,122446,123456,644221,644221,666666]	(6,9062)
Note: Lee and Zhang [48]			
PB[6,133]	(Known basis) Lee and Zhang [48, Proposition 14.4]	[111111,111111,113156,444444,113656,666666]	(6,12198)
		[111111,111111,333333,333456,555555,553456]	(6,12526)
		[111111,121256,333333,121256,126256,666666]	(6,14467)
Note: Lee and Zhang [48]			
PB[6,134]	(A) $xy \approx x^4y$ $xyz \approx xzy$ (B) $xy \approx x^4y$ $xyz \approx xzy$	[111111,111111,113156,444444,115163,116135]	(6,14901)
		[111111,111111,333333,333456,333564,333645]	(6,14911)
		[111111,121256,333333,121256,151562,161625]	(6,14954)
		[111111,121446,333333,141662,141662,161224]	(6,15915)
		[111156,111156,113356,114456,555561,666615]	(6,14930)
		[111156,122256,122256,144456,555561,666615]	(6,14949)
[111446,122446,133446,444661,444661,666114]	(6,15930)		
PB[6,135]	(A) $xy \approx y^5x$ (B) $xy \approx yx$ $xy \approx x^5y$	[111111,111111,113456,114365,115643,116534]	(6,9403)
		[111111,122456,122456,144265,155642,166524]	(6,5327)
		[111111,123356,132265,132265,156632,165523]	(6,5331)
		[111111,123356,135562,135562,156623,162235]	(6,9338)
		[111456,111456,113456,444165,555641,666514]	(6,5324)
		[111456,122456,122456,444165,555641,666514]	(6,9400)
		[113356,123356,331165,331165,556631,665513]	(6,5328)
[113356,123356,335561,335561,556613,661135]	(6,9335)		
PB[6,136]	(A) $xy \approx x^4y$ $x^2y \approx yx$ (B) $xy \approx x^3yx$	[111111,111111,113456,114536,115346,666666]	(6,14906)
		[111111,122456,122456,144526,155246,666666]	(6,14958)
		[111111,123356,135526,135526,152236,666666]	(6,15920)
PB[6,137]	(Known basis) Lee and Zhang [48, Proposition 14.1]	[111111,111111,123156,444444,123656,666666]	(6,12399)
Note: Lee and Zhang [48]			

Continued on next page

Table 9 – Continued from previous page

Id	Basis Proposal	Min.Lex	GAP
PB[6,138]	(A)	[111111,111111,123156,444444,125163,126135]	(6,14907)
	$xy \approx x^4y$	[111156,111156,123356,124456,555561,666615]	(6,14933)
	$xy^2x \approx x^2y^2$	[111446,122456,133456,444661,444661,666114]	(6,15933)
	$xyzx \approx xzyx$		
PB[6,139]	(A)	[111111,111111,123356,123356,123356,123556]	(6,10348)
	$xy \approx x^2y$	[111156,111156,111156,113456,111156,151156]	(6,8218)
	$xyzy \approx yxzy$	[111156,111156,111156,122456,111156,115156]	(6,8225)
	(B)	[111156,111156,123356,123356,111156,111556]	(6,11285)
	$xy \approx x^2y$	[111446,111446,111446,111446,113456,141446]	(6,8224)
	$xyz^2 \approx yxz^2$	[111446,111446,111446,111446,122456,114446]	(6,8229)
		[111446,111446,111446,116446,126456,111446]	(6,8236)
		[111446,111446,113456,111446,111446,141446]	(6,10985)
		[111446,111446,113456,161446,161446,111446]	(6,11117)
		[111446,111446,123446,111446,111446,111416]	(6,10979)
		[111446,111446,123446,111466,111466,111466]	(6,11127)
		[111446,122456,122456,111446,111446,114446]	(6,11397)
		[111446,122456,122456,116446,116446,111446]	(6,11405)
		[113336,113336,113366,123466,113366,113366]	(6,11120)
		[113336,123356,113636,113636,113636,113636]	(6,10977)
		[113336,123446,113366,113366,113366,113366]	(6,10978)
PB[6,140]	(A)	[111111,111111,123456,124365,125643,126534]	(6,9404)
	$xy \approx x^5y$	[111456,111456,123456,444165,555641,666514]	(6,5325)
	$xyx \approx yx^2$	[113356,123456,331165,331165,556631,665513]	(6,5329)
	$xy^2x \approx x^2y^2$	[113356,123456,335561,335561,556613,661135]	(6,9336)
PB[6,141]	(A)	[111111,111111,123456,124536,125346,666666]	(6,14910)
$xy \approx x^4y$			
$xy^2x \approx x^2y^2$			
PB[6,142]	(A)	[111111,111112,111112,111234,111234,123456]	(6,5352)
	$x^3 \approx x^4$		
	$xyz \approx yxz$		
	$x^2y^3x \approx x^3y^3$		
	(B)		
	$x^3 \approx x^4$		
$xyz \approx yxz$			
$x^3y^3 \approx x^2y^3x$			

Continued on next page

Table 9 – Continued from previous page

Id	Basis Proposal	Min.Lex	GAP
PB[6,143]	(A)	[111111,111112,111113,111114,111211,113116]	(6,1041)
	$x^2 \approx x^3$	[111111,111112,111113,111114,111211,113316]	(6,1045)
	$x^2y \approx xyx$	[111111,111112,111113,111114,111212,113116]	(6,1043)
	$x^2yz \approx x^2zy$	[111111,111112,111113,111114,111212,113316]	(6,1046)
	$xy^2x \approx y^2x^2$	[111111,111112,111113,111114,111213,113136]	(6,1100)
	(B)	[111111,111112,111113,111114,111213,113336]	(6,1102)
	$x^2 \approx x^3$	[111111,111112,111113,111121,112115,113116]	(6,1062)
	$x^2y \approx xyx$	[111111,111112,111113,111122,112115,113116]	(6,1063)
	$x^2y^2 \approx yx^2y$	[111111,111112,111113,111123,112215,113316]	(6,1134)
	$xyza \approx xyaz$		
PB[6,144]	(A)	[111111,111112,111113,111114,111215,121456]	(6,1118)
	$x^2 \approx x^3$	[111111,111112,111113,111114,111215,122456]	(6,1170)
	$x^2y \approx xyx$	[111111,111112,111113,111114,112215,123356]	(6,1193)
	$xyz^2 \approx xz^2y$	[111111,111112,111113,112114,112115,123446]	(6,1176)
	$xy^2x \approx y^2x^2$		
	(B)		
	$x^2 \approx x^3$		
	$x^2y \approx xyx$		
$x^2y^2 \approx yx^2y$			
$xy^2z \approx xzy^2$			
PB[6,145]	(A)	[111111,111112,111113,111114,111224,113116]	(6,2676)
	$xyx \approx x^3y$	[111111,111112,111113,111114,111224,113336]	(6,2680)
	$xy^2 \approx xy^3$	[111111,111112,111113,112114,112224,113116]	(6,2702)
	(B)		
	$xyx \approx x^3y$		
	$xy^2 \approx xy^3$		
	$xyxy \approx yx^2y$		
$xyza \approx xyaz$			

Continued on next page

Table 9 – Continued from previous page

Id	Basis Proposal	Min.Lex	GAP	
PB[6,146]	(A)	[111111,111112,111113,111114,111225,121456]	(6,2742)	
	$x^3 \approx x^4$	[111111,111112,111113,111114,111225,122456]	(6,2754)	
	$x^2y \approx xyx$	[111111,111112,111113,111114,112225,123356]	(6,2764)	
	$xyz^2 \approx xz^2y$	[111111,111112,111113,111124,111125,121456]	(6,2741)	
	$xy^2x \approx y^2x^2$	[111111,111112,111113,111124,111125,122456]	(6,2753)	
	(B)	[111111,111112,111113,111214,111225,121456]	(6,5211)	
	$x^3 \approx x^4$	[111111,111112,111113,111214,111225,122456]	(6,5222)	
	$x^2y \approx xyx$	[111111,111112,111113,112224,112225,123446]	(6,5248)	
	$x^2y^2 \approx yx^2y$	[111111,111112,111123,111124,111125,123356]	(6,2760)	
	$xy^2z \approx xzy^2$	[111111,111112,111223,111224,111225,123446]	(6,5247)	
	$x^2yz^2a \approx zyaxxz$	[111111,111112,112113,112224,112225,123446]	(6,9307)	
			[111111,111112,112123,112224,112125,123436]	(6,9306)
	PB[6,147]	(A)	[111111,111112,111113,111121,112125,113136]	(6,2636)
		$x^2y \approx xyx$	[111111,111112,111113,111122,112125,113136]	(6,2637)
$xy^2 \approx xy^3$		[111111,111112,111113,111123,112225,113336]	(6,2705)	
$x^2yz \approx x^2zy$				
PB[6,148]	(A)	[111111,111112,111113,111124,111245,121456]	(6,2808)	
	$xyz \approx xzy$	[111111,111112,111113,111124,111245,122456]	(6,2810)	
	$x^4 \approx x^5$	[111111,111112,111123,111124,112235,123356]	(6,2814)	
	$xy^2x \approx y^2x^2$	[111111,111112,111223,112334,112335,123446]	(6,5269)	
PB[6,149]	(A)	[111111,111112,111113,111124,112245,123456]	(6,2812)	
	$x^2y \approx xyx$	[111111,111112,111123,111124,111245,123456]	(6,2812)	
	$xy^2 \approx yxy$	[111111,111112,111123,111214,112235,123456]	(6,5358)	
	$x^4 \approx x^5$	[111111,111112,111123,111224,112135,123456]	(6,5358)	
PB[6,150]	(Known basis)	[111111,111112,111113,111214,112111,121456]	(6,2771)	
	Lee and Zhang	[111111,111112,111113,111214,112111,122456]	(6,2772)	
	[48, Proposition 15.1]	[111111,111112,111113,111214,112112,121456]	(6,2772)	
		[111111,111112,111113,111214,112112,122456]	(6,2773)	
		[111111,111112,111113,111224,112224,121456]	(6,5240)	
		[111111,111112,111113,111224,112224,122456]	(6,5241)	
		[111111,111112,111121,111224,111225,123446]	(6,5240)	
		[111111,111112,111122,111224,111225,123446]	(6,5241)	
		[111111,111112,112125,112224,112225,123556]	(6,9313)	
		Note: Lee and Zhang [48]		
PB[6,151]	(Known basis)	[111111,111112,111113,111214,113151,121416]	(6,5625)	
	Lee and Zhang	[111111,111112,111131,111214,111151,123416]	(6,5625)	
	[48, Proposition 12.8]	Note: Lee and Zhang [48]		

Continued on next page

CHAPTER 3 - OPEN PROBLEMS

Table 9 – Continued from previous page

Id	Basis Proposal	Min.Lex	GAP
PB[6,152]	(Known basis) Lee and Zhang [48, Proposition 12.4]	[111111,111112,111113,111214,113153,121416] [111111,111112,111131,111214,111151,123436] Note: Lee and Zhang [48]	(6,5626) (6,5626)
PB[6,153]	(A) $x^3 \approx x^4$ $xyx \approx yx^2$ $xy^2x \approx x^2y^2$ (B) $x^3 \approx x^4$ $xyx \approx yx^2$ $x^2y^2 \approx xy^2x$	[111111,111112,111113,111214,113155,123456] [111111,111112,111113,111214,113355,123456] [111111,111112,111133,111344,123455,123456] [111111,111112,123333,123334,123345,123456] [111111,111122,111123,111244,123455,123456] [111111,111122,112233,112234,123455,123456]	(6,5627) (6,5628) (6,5663) (6,9624) (6,5671) (6,9469)
PB[6,154]	(A) $x^3 \approx x^4$ $xyz \approx xzy$ $xy^3x^2 \approx y^3x^3$ (B) $x^3 \approx x^4$ $xyz \approx xzy$ $x^3y^3 \approx yx^3y^2$	[111111,111112,111113,111224,111335,122446]	(6,5352)
PB[6,155]	(A) $x^2 \approx x^3$ $xyx \approx x^2yx$ $xy^2x \approx x^2y^2$ $xy^2x \approx y^2x^2$ $x^2yz^2 \approx x^2zyz$ (B) $x^2 \approx x^3$ $xyx \approx x^2yx$ $x^2y^2 \approx yx^2y$ $x^2yzy \approx x^2zy^2$ $xyzaxz \approx xzyzaxz$	[111111,111112,111113,112111,121455,121456] [111111,111112,111113,112111,122455,122456] [111111,111112,111113,112112,121455,121456] [111111,111112,111113,112112,122455,122456]	(6,3806) (6,3809) (6,3819) (6,3822)

Continued on next page

Table 9 – Continued from previous page

Id	Basis Proposal	Min.Lex	GAP
PB[6,156]	(A)	[111111,111112,111113,112111,555555,111116]	(6,3810)
	$x^2 \approx x^3$	[111111,111112,111113,112111,555555,555556]	(6,3816)
	$x^2y \approx xyx$	[111111,111112,111113,112112,555555,111116]	(6,3823)
	$xyz \approx xyz^2$	[111111,111112,111113,112112,555555,555556]	(6,3829)
	$xyzy \approx xz^2y$	[111111,111112,111121,444444,444445,111116]	(6,6433)
	(B)	[111111,111112,111121,444444,444445,444446]	(6,6438)
	$x^2 \approx x^3$	[111111,111112,111122,444444,444445,111116]	(6,6440)
	$x^2y \approx xyx$	[111111,111112,111122,444444,444445,444446]	(6,6445)
	$xyz \approx xyz^2$	[111111,111113,111331,111441,111551,111661]	(6,3371)
	$xy^2z \approx xzyz$	[111111,111122,111133,112122,111155,111166]	(6,3377)
PB[6,157]	(A)	[111111,111112,111113,112111,555555,111156]	(6,3811)
	$x^2 \approx x^3$	[111111,111112,111113,112112,555555,111156]	(6,3824)
	$x^2y \approx xyx$	[111111,111112,111121,444444,444445,111446]	(6,6434)
	$xyz \approx xyz^2$	[111111,111112,111122,444444,444445,111446]	(6,6441)
	(B)		
	$x^2 \approx x^3$		
PB[6,158]	(A)	[111111,111112,111113,112111,555555,121416]	(6,3812)
	$x^2 \approx x^3$	[111111,111112,111113,112111,555555,122416]	(6,3814)
	$xyx \approx x^2yx$	[111111,111112,111113,112112,555555,121416]	(6,3825)
	$xy^2x \approx x^2y^2$	[111111,111112,111113,112112,555555,122416]	(6,3827)
	$x^2yz^2 \approx x^2zyz$	[111111,111112,111121,444444,444445,123116]	(6,6435)
	$xyxz^2 \approx x^2yz^2$	[111111,111112,111121,444444,444445,123126]	(6,6436)
	(B)	[111111,111112,111122,444444,444445,123116]	(6,6442)
	$x^2 \approx x^3$	[111111,111112,111122,444444,444445,123126]	(6,6443)
	$xyx \approx x^2yx$	[111111,111113,111331,123441,123551,111661]	(6,3938)
	$xyxzx \approx xzxyx$	[111111,111113,111331,123443,123553,111661]	(6,3941)
	$xy^2z^2 \approx xzy^2z$	[111111,111122,111133,112122,121455,121466]	(6,3942)
	$x^2yzaz \approx xzyzazx$	[111111,111122,111133,112122,122455,122466]	(6,3947)
PB[6,159]	(Known basis)	[111111,111112,111113,112111,555555,121456]	(6,3813)
	Lee and Zhang	[111111,111112,111113,112111,555555,122456]	(6,3815)
	[48, Proposition 16.1]	[111111,111112,111113,112112,555555,121456]	(6,3826)
		[111111,111112,111113,112112,555555,122456]	(6,3828)
		[111111,111112,111121,444444,444445,123446]	(6,6437)
		[111111,111112,111122,444444,444445,123446]	(6,6444)
	Note: Lee and Zhang [48]		

Continued on next page

Table 9 – Continued from previous page

Id	Basis Proposal	Min.Lex	GAP
PB[6,160]	(A) $x^2 \approx x^3$ $x^2y \approx xyx$ $xyz^2 \approx xz^2y$ (B) $x^2 \approx x^3$ $x^2y \approx xyx$ $xy^2z \approx xzy^2$	[111111,111112,111113,112114,555555,123416] [111111,111122,111133,112144,123455,123466]	(6,3839) (6,3950)
PB[6,161]	(A) $xy^2 \approx xy^3$ $x^2yz \approx x^2zy$ (B) $xy^2 \approx xy^3$ $xyxz \approx xzxy$ $xyza \approx xyaz$ $x^3y^2 \approx yx^2y^2$	[111111,111112,111113,112115,112225,113336]	(6,2708)
PB[6,162]	(Known basis) Lee and Zhang [48, Proposition 17.1]	[111111,111112,111113,112121,112123,121446] [111111,111112,111113,112122,112123,122446] Note: Lee and Zhang [48]	(6,2778) (6,2779)
PB[6,163]	(Known basis) Lee and Zhang [48, Proposition 18.1]	[111111,111112,111113,112141,113151,121416] Note: Lee and Zhang [48]	(6,3841)
PB[6,164]	(Known basis) Lee and Zhang [48, Proposition 19.1]	[111111,111112,111113,112141,113151,122446] Note: Lee and Zhang [48]	(6,3842)
PB[6,165]	(A) $x^2 \approx x^3$ $xyx \approx x^2yx$ $xy^2x \approx yxyx$ $xyxzx \approx xzxyx$ $xy^2zx \approx xyxzy$ (B) $x^2 \approx x^3$ $xyx \approx x^2yx$ $xyxy \approx yx^2y$ $xyxzx \approx xzxyx$ $xyzxay \approx xyzyax$ $xyzxay \approx xzyaxy$	[111111,111112,111113,112142,113153,121416]	(6,3842)

Continued on next page

Table 9 – Continued from previous page

<b>Id</b>	<b>Basis Proposal</b>	<b>Min.Lex</b>	<b>GAP</b>
PB[6,166]	Inherently non-finitely based	[111111,111112,111113,112142,113153,122446] Note: $L_3$	(6,3843)
PB[6,167]	(A) $x^2y \approx x^2y^2$ $xyx \approx x^3y$ $xy^2 \approx xy^3$ $x^2yz \approx x^2zy$ (B) $xyx \approx x^3y$ $xyz \approx xyz^2$ $xy^2z \approx xzyz$	[111111,111112,111113,112213,555555,111116] [111111,111112,111113,112213,555555,555556] [111111,111122,111133,112233,111155,111166]	(6,5635) (6,5637) (6,5580)
PB[6,168]	(A) $x^2y \approx x^2y^2$ $xyx \approx x^3y$ $xy^2 \approx xy^3$ (B) $xyx \approx x^3y$ $xyz \approx xyz^2$	[111111,111112,111113,112213,555555,111156]	(6,5636)
PB[6,169]	(A) $xy^2 \approx xy^3$ $xyz \approx xzy$ (B) $xy^2 \approx xy^3$ $xyz \approx xzy$	[111111,111112,111113,112214,555555,113316] [111111,111112,112123,444444,444445,445456] [111111,111122,111133,112244,113355,113366]	(6,5640) (6,9589) (6,5604)
PB[6,170]	(A) $x^2y \approx xyx$ $xy^2 \approx xy^3$ (B) $x^2y \approx xyx$ $xy^2 \approx xy^3$	[111111,111112,111113,112214,555555,113356]	(6,5641)
PB[6,171]	(A) $x^3 \approx x^4$ $x^2y \approx xyx$ $xyz^2 \approx xz^2y$	[111111,111112,111113,112214,555555,123416] [111111,111112,111123,444444,111125,123156] [111111,111112,112113,112214,555555,123416] [111111,111122,111133,112244,123455,123466] [111111,111122,111233,111244,123455,123466] [111111,111122,112133,112244,123455,123466]	(6,5642) (6,5648) (6,9442) (6,5675) (6,5676) (6,9461)

Continued on next page

Table 9 – Continued from previous page

Id	Basis Proposal	Min.Lex	GAP
PB[6,172]	(A)	[111111,111112,111113,113411,121155,121156]	(6,7943)
	$x^2 \approx x^3$	[111111,111112,111113,113444,123454,113446]	(6,7972)
	$xyx \approx xyx^2$	[111111,111112,111113,122444,123454,122446]	(6,8020)
	$xy^2x \approx x^2y^2$	[111111,111112,111131,113441,123451,111116]	(6,8116)
	$xy^2x \approx y^2x^2$	[111111,111112,111131,113444,123454,113446]	(6,8119)
	$xyxzx \approx xyzx$	[111111,111112,111131,123414,111151,123416]	(6,8120)
	$xyxz^2 \approx xzyxz$	[111111,111112,111133,113411,121155,121156]	(6,8169)
		[111111,111112,123333,123334,123453,123336]	(6,10897)
	[111111,111112,123333,123343,123353,123436]	(6,10906)	
PB[6,173]	(A)	[111111,111112,111113,113411,555555,121116]	(6,7946)
	$x^2 \approx x^3$	[111111,111112,111113,113441,113551,121116]	(6,7962)
	$xyx \approx x^2yx$	[111111,111112,111131,444444,111151,123116]	(6,8131)
	$xy^2x \approx x^2y^2$	[111111,111112,111131,444444,123151,444446]	(6,8156)
	$xyzx \approx xzyx$	[111111,111112,111331,111441,111551,123116]	(6,7974)
		[111111,111112,111331,123441,123551,111116]	(6,8249)
		[111111,111112,123111,444444,444445,444456]	(6,11025)
		[111111,111122,111133,113411,121155,121166]	(6,8252)
PB[6,174]	(A)	[111111,111112,111113,113411,555555,121156]	(6,7947)
	$x^2 \approx x^3$	[111111,111112,111113,113451,555555,121116]	(6,7979)
	$xyx \approx x^2yx$	[111111,111112,111131,444444,111151,123416]	(6,8133)
	$xyxzx \approx xyzx$	[111111,111112,111131,444444,111451,123116]	(6,8139)
	$xy^2zx \approx x^2zyz$	[111111,111112,111131,444444,123454,444446]	(6,8158)
	(B)	[111111,111112,113111,444444,445444,121456]	(6,11066)
	$x^2 \approx x^3$	[111111,111112,113451,444444,444445,121116]	(6,11016)
	$xyx \approx x^2yx$	[111111,111112,123111,444444,444445,111456]	(6,11023)
	$xyzx \approx yxzx$	[111111,111112,123451,444444,445444,111116]	(6,11085)
	$x^2zyz \approx xy^2zx$		

Continued on next page

Table 9 – Continued from previous page

Id	Basis Proposal	Min.Lex	GAP
PB[6,175]	(A)	[111111,111112,111113,113413,121155,121156]	(6,7950)
	$x^2 \approx x^3$	[111111,111112,111131,113441,123452,111116]	(6,8117)
	$xyx \approx xyx^2$	[111111,111112,111131,123434,111151,123436]	(6,8121)
	$xyxy \approx xy^2x$	[111111,111112,111133,113433,121155,121156]	(6,8172)
	$xy^2x \approx yxyx$	[111111,111112,123333,123334,123454,123336]	(6,10898)
	$xyxzx \approx xyzx$	[111111,111112,123333,123343,123353,123446]	(6,10907)
	$xyzxz \approx xzyxz$		
	(B)		
	$x^2 \approx x^3$		
	$xyx \approx xyx^2$		
	$xyxy \approx xy^2x$		
	$xyzx \approx xyxzx$		
	$xyzaxz \approx zyaxz$		
	PB[6,176]	(A)	[111111,111112,111113,113413,555555,121116]
$x^2 \approx x^3$		[111111,111112,111113,113443,113553,121116]	(6,7966)
$xyx \approx x^2yx$		[111111,111112,111131,444444,111151,123136]	(6,8132)
$xyxy \approx xy^2x$		[111111,111112,111131,444444,123152,444446]	(6,8157)
$xyzx \approx xzyx$		[111111,111112,111331,111441,111551,123336]	(6,7980)
$xyz^2y \approx xzyzy$		[111111,111112,111331,123442,123552,111116]	(6,8251)
		[111111,111112,123112,444444,444445,444456]	(6,11030)
		[111111,111122,111133,113433,121155,121166]	(6,8254)
PB[6,177]	(A)	[111111,111112,111113,113413,555555,121156]	(6,7954)
	$x^2 \approx x^3$	[111111,111112,111113,113453,555555,121116]	(6,7984)
	$xyx \approx x^2yx$	[111111,111112,111131,444444,111151,123436]	(6,8134)
	$xy^2zx \approx xyxzy$	[111111,111112,111131,444444,111451,123136]	(6,8140)
		[111111,111112,123112,444444,444445,111456]	(6,11028)
		[111111,111112,123452,444444,445444,111116]	(6,11086)
PB[6,178]	(A)	[111111,111112,111113,113451,113451,121116]	(6,7974)
	$x^2 \approx x^3$	[111111,111112,111331,111451,111451,123116]	(6,7962)
	$xyx \approx x^2yx$	[111111,111112,111331,123451,123451,111116]	(6,8252)
	$x^2y^2 \approx xyxy$	[111111,111122,111133,113411,121156,121156]	(6,8249)
	$xy^2x \approx yxyx$	[111116,111126,111136,113416,121156,111116]	(6,8131)
	$xyzx \approx xzyx$	[111116,111126,111316,111416,123156,111116]	(6,7946)
	(B)	[111155,111255,111355,113455,111155,121156]	(6,8156)
	$x^2 \approx x^3$	[111444,112444,113444,111444,111445,121456]	(6,11025)
	$xyx \approx x^2yx$		
	$x^2y^2 \approx yx^2y$		
	$xyzx \approx xzyx$		
	$x^2y^2z \approx xy^2xz$		

Continued on next page

Table 9 – Continued from previous page

Id	Basis Proposal	Min.Lex	GAP
PB[6,179]	(A) $x^2 \approx x^3$ $xyx \approx x^2yx$ $xyxy \approx yx^2y$ $xyzx \approx xzyx$ (B) $x^2 \approx x^3$ $xyx \approx x^2yx$ $xyxy \approx yx^2y$ $xyzx \approx xzyx$	[111111,111112,111113,113451,113453,121116] [111111,111112,111331,123451,123452,111116]	(6,7975) (6,8253)
PB[6,180]	(A) $x^2 \approx x^4$ $xyx \approx x^3yx$ $xy^2x \approx x^2y^2$ $xyzx \approx xzyx$ $xy^2x \approx y^2x^2$	[111111,111112,111113,113451,113541,121116] [111111,111112,111331,111451,111541,123116] [111111,111112,111331,123451,123541,111116] [111111,111122,111133,113411,121156,121165] [111116,111126,111136,113416,121156,666661] [111116,111126,111316,111416,123156,666661] [111155,111255,113155,121456,555511,556511] [111155,111255,113156,121455,555511,556511] [111155,111255,123155,111456,555511,556511] [111155,111255,123156,111455,555511,556511] [111444,121444,113456,444111,445111,464111] [111444,121446,113454,444111,445111,446111]	(6,6369) (6,6369) (6,6462) (6,6462) (6,4076) (6,4076) (6,4185) (6,4185) (6,4187) (6,4187) (6,4286) (6,4286)
PB[6,181]	(A) $x^2 \approx x^3$ $xyx \approx y^2x^2$ $xyzx \approx xzyx$	[111111,111112,111113,113451,133451,111116]	(6,7976)
PB[6,182]	(A) $x^2 \approx x^3$ $xyx \approx x^2yx$ $xyxy \approx yx^2y$ $xyzx \approx xzyx$ $xy^2xz \approx xyxyz$ (B) $x^2 \approx x^3$ $xyx \approx x^2yx$ $xyxy \approx yx^2y$ $xyzx \approx xzyx$ $xyxyz \approx xy^2xz$	[111111,111112,111113,113453,113453,121116] [111111,111112,111331,111451,111451,123336] [111111,111112,111331,123452,123452,111116] [111111,111122,111133,113433,121156,121156] [111116,111126,111136,113436,121156,111116] [111116,111126,111316,111416,123356,111116] [111155,111255,111355,113455,111155,121256] [111444,112444,113444,111444,111445,122456]	(6,7980) (6,7966) (6,8254) (6,8251) (6,8132) (6,7953) (6,8157) (6,11030)

Continued on next page

Table 9 – Continued from previous page

Id	Basis Proposal	Min.Lex	GAP	
PB[6,183]	(A)	[111111,111112,111113,113453,113543,121116]	(6,6370)	
	$x^2 \approx x^4$	[111111,111112,111331,111451,111541,123336]	(6,6370)	
	$xyx \approx x^3yx$	[111111,111112,111331,123452,123542,111116]	(6,6463)	
	$xyxy \approx xy^2x$	[111111,111122,111133,113433,121156,121165]	(6,6463)	
	$xyzx \approx xzyx$	[111116,111126,111136,113436,121156,666661]	(6,4077)	
	$xy^2x \approx yxyx$	[111116,111126,111316,111416,123356,666661]	(6,4077)	
			[111155,111255,123255,111456,555511,555611]	(6,4188)
PB[6,184]	(A)	[111111,111112,111113,113453,133453,111116]	(6,7982)	
	$x^2 \approx x^3$			
	$xyx^2 \approx xyx$			
	$xyxz^2 \approx yxyz^2$			
PB[6,185]	(A)	[111111,111112,111113,113454,113454,113456]	(6,7682)	
	$x^2 \approx x^3$	[111111,111112,111113,122454,122454,122456]	(6,8029)	
	$xyx \approx x^2yx$	[111111,111112,111333,121454,121454,121456]	(6,7715)	
	$xy^2x \approx yxyx$	[111111,111112,123353,123354,123353,123356]	(6,10934)	
	$xyz^2 \approx xzyz$	[111111,111122,111133,113444,113456,113456]	(6,7688)	
	$xy^2xz \approx x^2y^2z$	[111111,111122,111133,122444,122456,122456]	(6,8415)	
			[111111,111122,111333,121444,121456,121456]	(6,7718)
			[111111,111122,123333,123344,123356,123356]	(6,11222)
			[111116,111126,111136,113446,113456,111116]	(6,7628)
			[111116,111126,111136,122446,122456,111116]	(6,8332)
			[111116,111126,111336,121446,121456,111116]	(6,7653)
			[111116,111126,123336,123346,123356,111116]	(6,11425)

Continued on next page

Table 9 – Continued from previous page

Id	Basis Proposal	Min.Lex	GAP
PB[6,186]	(A)	[111111,111112,111113,113454,113545,113456]	(6,6246)
	$x^2 \approx x^4$	[111111,111112,111113,122454,122545,122456]	(6,6385)
	$xyx \approx x^3yx$	[111111,111112,111333,121454,121545,121456]	(6,6269)
	$xy^2x \approx x^2y^2$	[111111,111112,123353,123354,125535,123356]	(6,6858)
	$xyz^2 \approx xzyz$	[111111,111112,123443,124334,124335,123446]	(6,7001)
	$xy^2x \approx y^2x^2$	[111111,111122,111133,113444,113456,113465]	(6,6282)
		[111111,111122,111133,122444,122456,122465]	(6,6524)
		[111111,111122,111333,121444,121456,121465]	(6,6284)
		[111111,111122,123333,123344,123356,123365]	(6,9915)
		[111116,111126,111136,113446,113456,666661]	(6,4053)
		[111116,111126,111136,122446,122456,666661]	(6,4079)
		[111116,111126,111336,121446,121456,666661]	(6,4059)
		[111116,111126,123336,123346,123356,666661]	(6,6806)
		[111155,111255,113356,113456,555511,555611]	(6,4157)
		[111155,111255,123355,123455,555511,555611]	(6,4189)
		[111155,111255,123355,123455,555511,556611]	(6,4198)
		[111155,112255,113356,113456,555511,555611]	(6,4163)
		[111155,122256,122356,122456,555511,555611]	(6,6950)
	[111444,122446,123446,444111,445111,446111]	(6,4265)	
	[111444,122446,123446,444111,455111,446111]	(6,4271)	
	[111444,122455,123455,444111,445111,446111]	(6,4288)	
PB[6,187]	(Known basis)	[111111,111112,111113,113454,133454,113456]	(6,7987)
	Lee and Zhang [48, Proposition 17.5]	[111111,111112,111113,113455,133455,133456] Note: Lee and Zhang [48]	(6,7991)
PB[6,188]	(Known basis)	[111111,111112,111121,123444,123445,123446]	(6,6432)
	Lee and Zhang [48, Proposition 20.1]	[111111,111112,111122,123444,123445,123446] Note: Lee and Zhang [48]	(6,6439)
PB[6,189]	(A)	[111111,111112,111123,111234,112345,123456]	(6,5370)
	$xy \approx yx$ $x^5 \approx x^6$		
	(B)		
	$xy \approx yx$ $x^5 \approx x^6$		
PB[6,190]	(Known basis) Lee and Li [43, Chapter 8]	[111111,111112,111123,123434,111125,123456] Note: Lee and Li [43]	(6,5647)

Continued on next page

Table 9 – Continued from previous page

<b>Id</b>	<b>Basis Proposal</b>	<b>Min.Lex</b>	<b>GAP</b>
PB[6,191]	(Known basis) Lee and Li [43, Chapter 9]	[111111,111112,111123,123444,123445,123456] Note: Lee and Li [43]	(6,6447)
PB[6,192]	(A) $xyz \approx xzy$ $x^4 \approx x^5$	[111111,111112,111123,444444,112135,123156] [111111,111122,111233,112344,123455,123466]	(6,5689) (6,5692)
PB[6,193]	(A) $x^2y \approx xyx$ $x^4 \approx x^5$	[111111,111112,111123,444444,112135,123456]	(6,5690)
PB[6,194]	(A) $x^3 \approx x^4$ $x^2y \approx xyx$ $xy^2x \approx y^2x^2$	[111111,111112,111133,111214,111155,123456] [111111,111112,111133,111234,111155,123456] [111111,111122,111133,111244,121455,123456] [111111,111122,111133,111244,122455,123456] [111111,111122,112233,112244,123355,123456] [111111,112222,113333,113334,113345,123456]	(6,5627) (6,5628) (6,5663) (6,5671) (6,9469) (6,9624)
PB[6,195]	(A) $x^2 \approx x^3$ $xyx \approx x^2yx$ $xy^2x \approx y^2x^2$ $xyxzx \approx xyzx$ $xy^2zx \approx x^2yzy$	[111111,111112,111133,121411,111155,113156] [111111,111112,111331,111441,123451,111116] [111111,111112,111331,121441,123451,111116] [111111,111112,111333,111444,121454,113446] [111111,111112,111333,111444,123454,111446] [111111,111122,111133,113411,111155,121156] [111111,111222,111223,111444,123454,111446] [111111,112222,113333,113334,113453,123336] [111111,112222,113333,113334,123453,113336]	(6,8116) (6,7943) (6,8169) (6,8119) (6,7972) (6,8120) (6,8020) (6,10906) (6,10897)
PB[6,196]	(A) $x^2 \approx x^3$ $xyx \approx x^2yx$ $xy^2x \approx yxyx$ $xyxzx \approx xyzx$ $xy^2zx \approx xyxzy$	[111111,111112,111133,121412,111155,113156] [111111,111112,111331,111441,123452,111116] [111111,111112,111331,121442,123452,111116] [111111,111122,111133,113433,111155,121156] [111111,112222,113333,113334,113454,123336] [111111,112222,113333,113334,123454,113336]	(6,8117) (6,7950) (6,8172) (6,8121) (6,10907) (6,10898)
PB[6,197]	(A) $x^2 \approx x^3$ $xyx \approx x^2yx$ $xyx \approx xyx^2$ $xy^2x \approx x^2y^2$ $xyxzx \approx xyzx$ $xy^2y \approx xz^2y^2$	[111111,111112,111133,444444,121155,123156] [111111,111112,111333,121444,121555,123446] [111111,111122,111333,121444,123455,123466] [111111,111122,123113,444444,111155,123156] [111111,111122,123313,124414,111155,123356] [111111,111222,123113,111444,111555,123446] [111111,111222,123133,111444,123455,123466]	(6,8206) (6,8264) (6,8486) (6,13340) (6,13376) (6,13411) (6,13610)

Continued on next page

Table 9 – Continued from previous page

Id	Basis Proposal	Min.Lex	GAP
PB[6,198]	(A) $xy \approx xy^2$ $x^2yz \approx x^2zy$	[111111,111112,111141,444444,555555,111116]	(6,8218)
		[111111,111112,111141,444444,555555,444446]	(6,8224)
		[111111,111112,111142,444444,555555,111116]	(6,8225)
		[111111,111112,111142,444444,555555,444446]	(6,8229)
		[111111,111112,111144,444444,555555,555556]	(6,8236)
		[111111,111112,333333,333311,555555,555556]	(6,10977)
		[111111,111112,333333,333312,555555,555556]	(6,10978)
		[111111,111112,333333,333313,555555,111116]	(6,10979)
		[111111,111112,333333,333313,555555,333336]	(6,10985)
		[111111,111112,333333,335553,555555,111116]	(6,11127)
		[111111,111112,333333,335555,555555,333336]	(6,11120)
		[111111,111112,333333,335555,555555,555556]	(6,11117)
		[111111,111122,333333,444444,111155,111355]	(6,11285)
		[111111,111122,333333,444444,333166,333366]	(6,11397)
		[111111,111122,333333,444444,333355,443355]	(6,11405)
[111111,112222,113333,113335,115555,116666]	(6,10348)		
PB[6,199]	(A) $x^2 \approx x^3$ $xyx \approx xyx^2$ $xyx \approx xy^2x$ $xyz^2 \approx xyzzy$	[111111,111112,111141,444444,555555,113416]	(6,8219)
		[111111,111112,111141,444444,555555,113446]	(6,8220)
		[111111,111112,333333,333313,555555,113416]	(6,10980)
		[111111,111112,333333,333313,555555,113436]	(6,10981)
		[111111,111112,333333,335555,555555,333456]	(6,11119)
[111111,111112,333333,335555,555555,553456]	(6,11118)		
PB[6,200]	(A) $x^2 \approx x^3$ $xyx \approx xyx^2$ $x^2yz \approx x^2zy$ $xyxy \approx xy^2x$ (B) $x^2 \approx x^3$ $xyx \approx xyx^2$ $xyza \approx xyaz$	[111111,111112,111141,444444,555555,121116]	(6,8221)
		[111111,111112,111142,444444,555555,121116]	(6,8226)
		[111111,111112,333333,333313,555555,121116]	(6,10982)
		[111111,111112,333333,335553,555555,121116]	(6,11128)
		[111111,111122,333333,444444,121155,121355]	(6,11331)
		[111111,112222,123333,123335,125555,126666]	(6,11579)
PB[6,201]	(Known basis) Lee and Zhang [48, Proposition 21.1]	[111111,111112,111141,444444,555555,123416]	(6,8222)
		[111111,111112,111141,444444,555555,123446]	(6,8223)
		[111111,111112,111142,444444,555555,123416]	(6,8227)
		[111111,111112,111142,444444,555555,123446]	(6,8228)
		[111111,111112,333333,333313,555555,123416]	(6,10983)
		[111111,111112,333333,333313,555555,123436]	(6,10984)
Note: Lee and Zhang [48]			

Continued on next page

Table 9 – Continued from previous page

Id	Basis Proposal	Min.Lex	GAP
PB[6,202]	(A)	[111111,111112,111143,444444,555555,121156]	(6,8232)
	$x^2 \approx x^3$	[111111,111112,111143,444444,555555,122156]	(6,8233)
	$xyx \approx xyx^2$	[111111,111112,333333,333314,555555,121156]	(6,10988)
	$xyzy \approx xy^2z$	[111111,111112,333333,333314,555555,121256]	(6,10989)
	(B)	[111111,111112,333333,335554,555555,123336]	(6,11126)
	$x^2 \approx x^3$	[111111,111112,333333,335554,555555,125556]	(6,11124)
PB[6,203]	$xyx \approx xyx^2$		
	$xy^2z \approx xyzy$		
	(A)	[111111,111112,111233,111234,123455,123456]	(6,5654)
	$x^3 \approx x^4$		
	$xyx \approx yx^2$		
	$x^2y^3x \approx x^3y^3$		
PB[6,204]	(B)		
	$x^3 \approx x^4$		
	$xyx \approx yx^2$		
	$x^3y^3 \approx x^2y^3x$		
	(A)	[111111,111112,111331,111441,111551,123136]	(6,7975)
	$x^2 \approx x^3$	[111111,111122,111133,113413,121155,121166]	(6,8253)
PB[6,205]	$xyx \approx x^2yx$		
	$xyxy \approx xy^2x$		
	$xyzx \approx xzyx$		
	(A)	[111111,111112,111333,121454,121454,123456]	(6,8264)
	$x^2 \approx x^3$	[111111,111122,111333,121444,123456,123456]	(6,8486)
	$xyx \approx x^2yx$	[111111,111122,123413,123413,111155,123456]	(6,13411)
$xyx \approx xyx^2$	[111111,111222,123113,111454,111454,123456]	(6,13376)	
$xy^2x \approx yxyx$	[111111,111222,123133,111444,123456,123456]	(6,13610)	
$xyxzx \approx xyzx$	[111116,111126,111336,121446,123456,111116]	(6,8206)	
$xy^2xz \approx x^2y^2z$	[111116,111226,123136,111446,123456,111116]	(6,13340)	
PB[6,206]	(A)	[111111,111112,111333,121454,121545,123456]	(6,6471)
	$x^2 \approx x^4$	[111111,111122,111333,121444,123456,123465]	(6,6550)
	$xyx \approx x^3yx$	[111111,111122,123413,124314,111155,123456]	(6,11230)
	$x^2yx \approx xyx^2$	[111111,111222,123113,111454,111545,123456]	(6,11230)
	$xy^2x \approx x^2y^2$	[111111,111222,123133,111444,123456,123465]	(6,11521)
	$xy^2x \approx y^2x^2$	[111116,111126,111336,121446,123456,666661]	(6,4089)
		[111116,111226,123136,111446,123456,666661]	(6,8873)
		[111155,111255,123355,123456,555511,556611]	(6,4199)
		[111155,112255,113356,123456,555511,555611]	(6,4199)
		[111155,121255,113356,123456,555511,565611]	(6,9017)
		[111444,122446,123456,444111,455111,446111]	(6,4295)

Continued on next page

CHAPTER 3 - OPEN PROBLEMS

Table 9 – Continued from previous page

Id	Basis Proposal	Min.Lex	GAP
PB[6,207]	(Known basis) Edmunds et al. [12, Theorem 3.2]	[111111,111112,112143,444444,555555,123456] Note: Edmunds et al. [12]	(6,9726)
PB[6,208]	(A)	[111111,111112,113153,444444,113155,113456]	(6,12774)
	$xy \approx xy^2$	[111111,111112,113453,113454,555555,113456]	(6,12885)
	$x^2yzy \approx xyxzy$	[111111,111112,333333,333454,333455,113456]	(6,13136)
	(B)	[111111,111222,333333,111446,113456,111466]	(6,13664)
	$xy \approx xy^2$	[111111,111222,333333,113446,113456,113466]	(6,13685)
	$x^2yz \approx xyxzyz$	[111111,111222,333333,113456,333556,333656]	(6,13698)
		[111111,121226,333333,121246,123256,121266]	(6,14222)
		[111111,122256,122356,122456,122556,666666]	(6,14223)
		[111116,111126,113336,114446,113456,111166]	(6,12185)
		[111116,111126,113336,114446,113456,116666]	(6,12324)
		[111116,112226,113336,113456,115556,111616]	(6,12392)
		[111116,112226,113336,113456,115556,116666]	(6,12462)
		[111116,122226,122236,144446,122456,111166]	(6,14252)
		[111116,122226,122236,144446,122456,166666]	(6,14253)
		[111155,111255,333366,113456,111555,333666]	(6,14080)
	[111155,122255,123455,144455,115155,116155]	(6,12492)	

Continued on next page

Table 9 – Continued from previous page

Id	Basis Proposal	Min.Lex	GAP	
PB[6,209]	(A)	[111111,111112,113153,444444,113155,123456]	(6,12776)	
	$x^2 \approx x^3$	[111111,111112,113453,113454,555555,123456]	(6,12886)	
	$xyx \approx x^2yx$	[111111,111112,123153,444444,123155,123456]	(6,12967)	
	$xyx \approx xyx^2$	[111111,111112,123453,123454,555555,123456]	(6,13058)	
	$x^2y^2 \approx xyxy$	[111111,111112,333333,333454,333455,123456]	(6,13137)	
	$xyxzx \approx xyzx$	[111111,111222,333333,111446,123456,111466]	(6,13668)	
			[111111,111222,333333,113446,123456,113466]	(6,13689)
			[111111,111222,333333,121446,123456,121466]	(6,13716)
			[111111,111222,333333,123446,123456,123466]	(6,13726)
			[111111,111222,333333,123456,333556,333656]	(6,13736)
			[111111,121226,333333,121246,123456,121266]	(6,14262)
			[111111,122256,122356,123456,122556,666666]	(6,14263)
			[111116,111126,113336,114446,123456,111166]	(6,12776)
			[111116,111126,113336,114446,123456,116666]	(6,12886)
			[111116,111126,123336,124446,123456,111166]	(6,13668)
			[111116,111126,123336,124446,123456,116666]	(6,13689)
			[111116,112226,113336,114446,123456,111166]	(6,12967)
			[111116,112226,113336,114446,123456,116666]	(6,13058)
			[111116,112226,123336,123456,125556,111616]	(6,13716)
			[111116,112226,123336,123456,125556,116666]	(6,13726)
			[111116,122226,122236,144446,123456,111166]	(6,14262)
			[111116,122226,122236,144446,123456,166666]	(6,14263)
			[111155,111255,333366,123456,111555,333666]	(6,14152)
			[111155,122255,123456,144455,115155,116155]	(6,13137)
			[111155,122256,123456,144456,115155,116155]	(6,13736)
	PB[6,210]	(A)	[111111,111112,113451,444444,445134,121116]	(6,10837)
		$x^2 \approx x^4$	[111111,111112,113453,444444,445135,123456]	(6,10842)
		$xyx \approx x^3yx$	[111111,111122,113333,114444,123456,124365]	(6,11385)
$x^2y \approx x^2yx^2$		[111111,111122,333333,333344,123456,341265]	(6,9937)	
(B)		[111111,111122,333333,444444,123456,124365]	(6,11396)	
$x^2 \approx x^4$		[111111,111222,333333,113446,123456,331664]	(6,11459)	
$x^2y \approx x^2yx^2$		[111111,112222,113333,114444,123456,124365]	(6,11392)	
$xyx \approx x^3yx$		[111111,112222,123333,123456,125555,125634]	(6,11598)	
$xyz^2ax \approx xyz^2azxz$		[111111,122256,122356,123456,555555,566612]	(6,8924)	
			[111111,122446,123456,644221,645221,666666]	(6,9065)

Continued on next page

Table 9 – Continued from previous page

Id	Basis Proposal	Min.Lex	GAP
PB[6,211]	(A)	[111111,111112,123151,444444,123151,111116]	(6,12949)
	$x^2 \approx x^3$	[111111,111112,123151,444444,123151,444446]	(6,12951)
	$xyx \approx x^2yx$	[111111,111122,123111,444444,111156,111156]	(6,13327)
	$xyx \approx xy^2x$	[111111,111122,123111,444444,444456,444456]	(6,13334)
	$x^2y^2 \approx xyxy$	[111111,111122,123311,124411,111156,111156]	(6,13371)
	$xyzx \approx xzyx$	[111111,111122,123411,123411,111155,111166]	(6,13402)
		[111116,111126,123316,124416,111156,111116]	(6,13327)
		[111116,111226,123116,111446,111556,111116]	(6,12949)
		[111155,112255,113355,114455,111155,121156]	(6,12951)
	[111444,112444,113444,111444,121455,121466]	(6,13334)	
PB[6,212]	(A)	[111111,111112,123151,444444,123151,111416]	(6,12950)
	$x^2 \approx x^3$	[111111,111112,123451,123451,555555,111116]	(6,13045)
	$xyx \approx x^2yx$	[111111,111112,123454,444444,123454,444446]	(6,13061)
	$xyx \approx xy^2x$	[111111,111122,123111,444444,111456,111456]	(6,13330)
	$x^2y^2z \approx xyxz$	[111111,111122,123411,444444,111156,111156]	(6,13407)
	[111111,111122,123444,444444,444456,444456]	(6,13438)	
PB[6,213]	(A)	[111111,111112,123151,444444,123152,111116]	(6,12952)
	$x^2 \approx x^3$	[111111,111112,123151,444444,123152,444446]	(6,12954)
	$xyx \approx x^2yx$	[111111,111122,123411,123422,111155,111166]	(6,13404)
	$xyzx \approx xzyx$		
	$xyzyz \approx xzyz$		
PB[6,214]	(A)	[111111,111112,123151,444444,123152,111416]	(6,12953)
	$x^2 \approx x^3$	[111111,111112,123451,123452,555555,111116]	(6,13047)
	$xyx \approx x^2yx$		
	$xyx \approx xy^2x$		
	$xyzxy \approx xyxzy$		
PB[6,215]	(A)	[111111,111112,123151,444444,125131,111116]	(6,10949)
	$x^2 \approx x^4$	[111111,111112,123151,444444,125131,444446]	(6,10951)
	$xyx \approx x^3yx$	[111111,111122,123111,444444,111156,111165]	(6,11299)
	$xyx \approx xy^3x$	[111111,111122,123111,444444,444456,444465]	(6,11410)
	$xy^2x \approx x^2y^2$	[111111,111122,123311,124411,111156,111165]	(6,11228)
	$xyzx \approx xzyx$	[111111,111122,123411,124311,111155,111166]	(6,11227)
		[111116,111126,123316,124416,111156,666661]	(6,8856)
		[111116,111226,123116,111446,111556,666661]	(6,8863)
		[111155,121155,113356,114456,555511,565511]	(6,9004)
		[111155,121156,113355,114455,555511,556611]	(6,9009)

Continued on next page

Table 9 – Continued from previous page

Id	Basis Proposal	Min.Lex	GAP
PB[6,216]	(A)	[111111,111112,123151,444444,125131,111416]	(6,10950)
	$x^2 \approx x^4$	[111111,111112,123451,124351,555555,111116]	(6,10967)
	$xyx \approx x^3yx$	[111111,111112,123454,444444,125434,444446]	(6,10976)
	$xyx \approx xy^3x$	[111111,111122,123111,444444,111456,111465]	(6,11306)
	$xy^2x \approx x^2y^2$	[111111,111122,123411,444444,111156,111165]	(6,11300)
		[111111,111122,123444,444444,444456,444465]	(6,11412)
PB[6,217]	(A)	[111111,111112,123152,444444,123152,111116]	(6,12958)
	$x^2 \approx x^3$	[111111,111112,123152,444444,123152,444446]	(6,12960)
	$xyx \approx x^2yx$	[111111,111122,123122,444444,111156,111156]	(6,13348)
	$xyxyz \approx xyxz$	[111111,111122,123122,444444,444456,444456]	(6,13355)
	$xyzzy \approx xzyz$	[111111,111122,123322,124422,111156,111156]	(6,13382)
	(B)	[111111,111122,123422,123422,111155,111166]	(6,13416)
	$x^2 \approx x^3$	[111116,111126,123326,124426,111156,111116]	(6,13348)
	$xyx \approx x^2yx$	[111116,111226,123226,111446,111556,111116]	(6,12958)
	$xyxz \approx xyxyz$	[111155,112255,113355,114455,111155,122256]	(6,12960)
	$xyzzy \approx xzyzy$	[111444,112444,113444,111444,122455,122466]	(6,13355)
PB[6,218]	(A)	[111111,111112,123152,444444,123152,111416]	(6,12959)
	$x^2 \approx x^3$	[111111,111112,123452,123452,555555,111116]	(6,13051)
	$xyx \approx x^2yx$	[111111,111122,123122,444444,111456,111456]	(6,13351)
	$xyx \approx xy^2x$	[111111,111122,123422,444444,111156,111156]	(6,13419)
	$xyxyz \approx xyxz$		
PB[6,219]	(A)	[111111,111112,123152,444444,125132,111116]	(6,10954)
	$x^2 \approx x^4$	[111111,111112,123152,444444,125132,444446]	(6,10956)
	$xyx \approx x^3yx$	[111111,111122,123122,444444,111156,111165]	(6,11301)
	$xyx \approx xy^3x$	[111111,111122,123122,444444,444456,444465]	(6,11411)
	$xyxy \approx xy^2x$	[111111,111122,123322,124422,111156,111165]	(6,11233)
	$xyz^2y \approx xzyzy$	[111111,111122,123422,124322,111155,111166]	(6,11232)
		[111116,111126,123326,124426,111156,666661]	(6,8858)
		[111116,111226,123226,111446,111556,666661]	(6,8865)
PB[6,220]	(A)	[111111,111112,123152,444444,125132,111416]	(6,10955)
	$x^2 \approx x^4$	[111111,111112,123452,124352,555555,111116]	(6,10970)
	$xyx \approx x^3yx$	[111111,111122,123122,444444,111456,111465]	(6,11307)
	$xyx \approx xy^3x$	[111111,111122,123422,444444,111156,111165]	(6,11302)
	$x^2yx \approx xyx^2$		
	$xyxy \approx xy^2x$		

Continued on next page

Table 9 – Continued from previous page

Id	Basis Proposal	Min.Lex	GAP
PB[6,221]	(A)	[111111,111112,123153,444444,123153,123156]	(6,12964)
	$x^2 \approx x^3$	[111111,111122,123133,444444,123156,123156]	(6,13363)
	$xyx \approx x^2yx$	[111111,111122,123333,124444,123356,123356]	(6,13398)
	$xyz^2 \approx xzyz$	[111111,111122,123433,123433,123455,123466]	(6,13425)
	$xy^2xz \approx x^2y^2z$	[111116,111126,123336,124446,123356,111116]	(6,13665)
		[111116,111226,123336,123446,123556,111116]	(6,13654)
PB[6,222]	(A)	[111111,111112,123153,444444,123153,123456]	(6,12965)
	$x^2 \approx x^3$	[111111,111112,123453,123453,555555,123456]	(6,13056)
	$xyx \approx x^2yx$	[111111,111122,123133,444444,123456,123456]	(6,13366)
	$xyx \approx xyx^2$	[111111,111122,123333,124444,123456,123456]	(6,13401)
	$xyxzx \approx xyzx$	[111111,111122,123433,444444,123456,123456]	(6,13433)
	$xy^2xz \approx x^2y^2z$	[111116,111126,123336,124446,123456,111116]	(6,13666)
	(B)		
	$x^2 \approx x^3$		
	$xyx \approx x^2yx$		
	$xyx \approx xyx^2$		
	$xyxzx \approx xyxzx$		
	$x^2y^2z \approx xy^2xz$		
PB[6,223]	(A)	[111111,111112,123153,444444,125135,123156]	(6,10959)
	$x^2 \approx x^4$	[111111,111122,123133,444444,123156,123165]	(6,11370)
	$xyx \approx x^3yx$	[111111,111122,123333,124444,123356,123365]	(6,11375)
	$xy^2x \approx x^2y^2$	[111111,111122,123433,124344,123455,123466]	(6,11236)
	$xyz^2 \approx xzyz$	[111116,111126,123336,124446,123356,666661]	(6,8861)
		[111116,111226,123336,123446,123556,666661]	(6,8876)
		[111155,122256,123256,144456,555511,556511]	(6,9007)
		[111155,122256,123356,124456,555511,556611]	(6,9019)
PB[6,224]	(A)	[111111,111112,123153,444444,125135,123456]	(6,10960)
	$x^2 \approx x^4$	[111111,111112,123453,124354,555555,123456]	(6,10973)
	$xyx \approx x^3yx$	[111111,111122,123133,444444,123456,123465]	(6,11386)
	$x^2yx \approx xyx^2$	[111111,111122,123333,124444,123456,123465]	(6,11388)
	$xy^2x \approx x^2y^2$	[111111,111122,123433,444444,123456,123465]	(6,11391)
		[111116,111126,123336,124446,123456,666661]	(6,8862)
		[111155,122256,123456,144456,555511,556511]	(6,9008)
PB[6,225]	(A)	[111111,111112,123451,124531,125341,111116]	(6,14914)
	$x^2 \approx x^5$	[111111,111222,123111,111456,111564,111645]	(6,14914)
	$xyx \approx y^4x^2$	[111156,111256,123156,111456,555561,666615]	(6,14937)
	$xy^2x \approx x^2y^2$	[111446,121446,113456,444661,454661,666114]	(6,15924)

Continued on next page

Table 9 – Continued from previous page

Id	Basis Proposal	Min.Lex	GAP
PB[6,226]	(A)	[111111,111112,123452,124532,125342,111116]	(6,14915)
	$x^2 \approx x^5$	[111111,111222,123222,111456,111564,111645]	(6,14915)
	$xyx \approx y^3xyx$	[111156,111256,123256,111456,555561,666615]	(6,14938)
	$xyxy \approx xy^2x$		
PB[6,227]	(A)	[111111,111112,123453,124534,125345,123456]	(6,14916)
	$x^2 \approx x^5$	[111111,111222,123333,123456,123564,123645]	(6,14919)
	$xyx \approx yx^2$	[111156,111256,123356,123456,555561,666615]	(6,14939)
	$xy^2x \approx x^2y^2$	[111446,122456,123456,444661,445661,666114]	(6,15929)
PB[6,228]	(A)	[111111,111113,111133,111144,111455,111466]	(6,3339)
	$x^2 \approx x^3$	[111111,111122,111124,111144,122255,122266]	(6,3889)
	$x^2y \approx xyx$	[111111,111122,111124,111144,122255,144466]	(6,3930)
	$x^2yz \approx x^2zy$	[111111,111122,111124,111144,144455,122266]	(6,3932)
PB[6,229]	(Known basis) Lee and Zhang [48, Proposition 20.7]	[111111,111113,111133,111344,123455,123466] Note: Lee and Zhang [48]	(6,5661)
PB[6,230]	(Known basis) Lee [37, Proposition 5.1]	[111111,111113,111133,123411,111155,111166] Note: Lee [37]	(6,7976)
PB[6,231]	(A) $x^2 \approx x^3$ $xyx \approx x^2yx$ $x^2yzy \approx x^2zyz$	[111111,111113,111133,123433,111155,111166]	(6,7982)
PB[6,232]	(Known basis) Lee and Zhang [48, Proposition 22.1]	[111111,111113,111133,123444,123455,123466] Note: Lee and Zhang [48]	(6,8276)
PB[6,233]	(Known basis) Lee and Zhang [48, Proposition 22.5]	[111111,111113,111133,444444,123455,123466] Note: Lee and Zhang [48]	(6,8281)
PB[6,234]	(A)	[111111,111113,111331,111441,123451,111661]	(6,3806)
	$x^2 \approx x^3$	[111111,111113,111331,111441,123453,111661]	(6,3819)
	$xyx \approx xyx^2$	[111111,111122,111133,112122,111155,121456]	(6,3809)
	$xy^2x \approx x^2y^2$	[111111,111122,111133,112122,111155,122456]	(6,3822)
	$xy^2x \approx y^2x^2$ $x^2yz^2 \approx xyxz^2$		

Continued on next page

Table 9 – Continued from previous page

Id	Basis Proposal	Min.Lex	GAP
PB[6,235]	(A) $x^2 \approx x^3$ $x^2y \approx xyx$ $xyz \approx x^2yz$	[111111,111113,111331,111451,111451,111661] [111111,111122,111133,112122,111156,111156] [111116,111126,111136,112116,111156,111116] [111116,111126,111136,112126,111156,111116] [111155,111255,111355,111455,111155,112155] [111155,111255,111355,111455,111155,112255]	(6,3370) (6,3376) (6,3368) (6,3374) (6,6175) (6,6176)
PB[6,236]	(A) $x^2 \approx x^4$ $x^2y \approx xyx$ $xyz \approx xyz^3$ $xyx \approx y^3x^2$	[111111,111113,111331,111451,111541,111661] [111111,111122,111133,112122,111156,111165] [111116,111126,111136,112116,111156,666661] [111116,111126,111136,112126,111156,666661] [111444,111445,113444,444111,445111,446111] [111444,112444,113444,444111,444112,446111] [111444,112444,113444,444111,445111,454111] [111444,112444,113444,444111,445111,455111]	(6,2960) (6,2962) (6,1237) (6,1238) (6,1323) (6,1319) (6,1349) (6,1351)
PB[6,237]	(A) $x^2 \approx x^3$ $xyx \approx x^2yx$ $xy^2x \approx yxyx$ $x^2yz^2 \approx x^2zyz$ $xyxz^2 \approx x^2yz^2$	[111111,111113,111331,123451,123451,111661] [111111,111113,111331,123453,123453,111661] [111111,111122,111133,112122,121456,121456] [111111,111122,111133,112122,122456,122456] [111116,111126,111136,112116,121456,111116] [111116,111126,111136,112116,122456,111116] [111116,111126,111136,112126,121456,111116] [111116,111126,111136,112126,122456,111116] [111155,111255,111355,113456,111155,131155] [111155,111255,111355,113456,111155,131355] [111155,111255,111355,122456,111155,112155] [111155,111255,111355,122456,111155,112255]	(6,3938) (6,3942) (6,3941) (6,3947) (6,3812) (6,3825) (6,3814) (6,3827) (6,6435) (6,6436) (6,6442) (6,6443)

Continued on next page

Table 9 – Continued from previous page

Id	Basis Proposal	Min.Lex	GAP
PB[6,238]	(A)	[111111,111113,111331,123451,123541,111661]	(6,3045)
	$x^2 \approx x^4$	[111111,111113,111331,123453,123543,111661]	(6,3047)
	$xyx \approx x^3yx$	[111111,111122,111133,112122,121456,121465]	(6,3047)
	$xy^2x \approx x^2y^2$	[111111,111122,111133,112122,122456,122465]	(6,3049)
	$xy^2x \approx y^2x^2$	[111116,111126,111136,112116,121456,666661]	(6,1259)
	$x^2yz^2 \approx x^2zyz$	[111116,111126,111136,112116,122456,666661]	(6,1260)
		[111116,111126,111136,112126,121456,666661]	(6,1260)
		[111116,111126,111136,112126,122456,666661]	(6,1261)
		[111444,111445,123454,444111,445111,446111]	(6,1350)
		[111444,111445,123455,444111,445111,446111]	(6,1352)
		[111444,112444,113456,444111,445111,454111]	(6,1350)
		[111444,112444,113456,444111,445111,455111]	(6,1352)
		[111444,112444,123446,444111,445111,444121]	(6,1347)
PB[6,239]	(A)	[111111,111113,111333,111444,123454,111666]	(6,7987)
	$x^2 \approx x^3$	[111111,111133,111333,111444,111555,123556]	(6,7991)
	$xyx \approx x^2yx$ $x^2yz^2 \approx xyzxz$ $xy^2zx \approx x^2zyz$		
PB[6,240]	(A)	[111111,111113,333333,111235,555555,666666]	(6,9727)
	$x^2y \approx x^2yz$ $xyx \approx xy^2$ $xy^2 \approx xy^2z$		
PB[6,241]	(A)	[111111,111113,333333,111451,111451,666666]	(6,13171)
	$xy \approx xy^2$	[111111,111113,333333,333453,333453,666666]	(6,13196)
	$xyxz \approx xyz$	[111111,111333,333333,444444,444456,444456]	(6,13777)
		[111111,121126,333333,444444,121326,121126]	(6,14465)
		[111116,122226,122246,144446,155556,111116]	(6,14271)
PB[6,242]	(A)	[111111,111113,333333,111451,111541,666666]	(6,11162)
	$xy \approx xyx^2$	[111111,111113,333333,333453,333543,666666]	(6,11170)
	$x^2yz \approx x^2zy$	[111111,111333,333333,444444,444456,444465]	(6,11602)
		[111111,121126,333333,444444,121326,161162]	(6,8932)
		[111111,121155,333333,444444,151122,151322]	(6,9073)
		[111116,122226,122246,144446,155556,666661]	(6,11782)

Continued on next page

Table 9 – Continued from previous page

Id	Basis Proposal	Min.Lex	GAP
PB[6,243]	(A) $xy \approx xyx$	[111111,111113,333333,111451,555555,666666]	(6,13172)
		[111111,111113,333333,111455,555555,666666]	(6,13173)
		[111111,111113,333333,333453,555555,666666]	(6,13197)
		[111111,111113,333333,333455,555555,666666]	(6,13198)
		[111111,111333,333333,444444,444456,666666]	(6,13778)
		[111111,121126,333333,444444,121326,666666]	(6,14537)
		[111111,122226,122246,144446,155556,666666]	(6,14270)
PB[6,244]	(A) $x^2 \approx x^3$ $xyx \approx xyx^2$ $xy^2z \approx xyxz$	[111111,111113,333333,123451,123451,666666]	(6,13184)
		[111111,111113,333333,123453,123453,666666]	(6,13188)
PB[6,245]	(Known basis) Lee and Zhang [48, Proposition 22.9]	[111111,111113,333333,123451,123453,666666] Note: Lee and Zhang [48]	(6,13185)
PB[6,246]	(Known basis) Lee and Zhang [48, Proposition 23.1]	[111111,111113,333333,123451,123541,666666]	(6,11165)
		[111111,111113,333333,123453,123543,666666] Note: Lee and Zhang [48]	(6,11166)
PB[6,247]	(A) $x^2 \approx x^3$ $xyx \approx xyx^2$ $x^2y^2 \approx xyxy$ $x^2yz \approx x^2zy$	[111111,111122,111133,111144,111455,112455]	(6,2980)
		[111111,111122,111133,111144,122255,122355]	(6,3032)
		[111111,111122,111133,112144,113155,113255]	(6,2986)
PB[6,248]	(A) $x^2 \approx x^4$ $xyx \approx x^3yx$ $xyz^2 \approx xz^2y$ $xy^2x \approx y^2x^2$	[111111,111122,111133,111144,113456,114365]	(6,3008)
		[111111,111122,111133,111144,122456,144265]	(6,3040)
		[111111,111122,111134,111143,113456,113465]	(6,3006)
PB[6,249]	(A) $x^3 \approx x^4$ $xyxz \approx x^2yz$ $xy^2x \approx yxyx$ $xyzx \approx xzyx$	[111111,111122,111133,111244,121456,121456]	(6,5659)
		[111111,111122,111133,111244,122456,122456]	(6,5668)
		[111111,111122,112233,112244,123356,123356]	(6,9466)
		[111116,111126,111136,111246,121456,111116]	(6,5613)
		[111116,111126,111136,111246,122456,111116]	(6,5621)
		[111116,111126,112236,112246,123356,111116]	(6,9450)

Continued on next page

Table 9 – Continued from previous page

Id	Basis Proposal	Min.Lex	GAP
PB[6,250]	(A)	[111111,111122,111133,111244,121456,121465]	(6,5453)
	$x^3 \approx x^5$	[111111,111122,111133,111244,122456,122465]	(6,5457)
	$xyz \approx xzy$	[111111,111122,112233,112244,123356,123365]	(6,9383)
	$xy^2x \approx y^2x^2$	[111116,111126,111136,111246,121456,666661]	(6,2856)
	(B)	[111116,111126,111136,111246,122456,666661]	(6,2858)
	$xyz \approx xzy$	[111116,111126,112236,112246,123356,666661]	(6,5305)
	$x^2y^2 \approx yx^2y$	[111155,111255,111355,113456,555511,555613]	(6,2872)
	$x^3 \approx x^5$	[111155,111255,111355,122456,555511,555612]	(6,2874)
	$xyz \approx xzy$	[111155,111255,112355,123455,555511,555611]	(6,2881)
	$x^2y^2 \approx yx^2y$	[111444,112444,123446,444111,445111,446112]	(6,2894)
$x^3 \approx x^5$	[111444,112444,123455,444111,445122,446122]	(6,5319)	
PB[6,251]	(A)	[111111,111122,111133,111244,121456,122456]	(6,5661)
	$x^3 \approx x^4$		
	$x^2yx \approx xyx^2$		
	$xyxy \approx x^2y^2$		
PB[6,252]	(A)	[111111,111122,111133,112112,111155,111166]	(6,3372)
	$x^2 \approx x^3$		
	$x^2y \approx xyx$		
	$xyz \approx xyz^2$		
	$x^2yz \approx x^2zy$		
	(B)		
	$x^2 \approx x^3$		
	$x^2y \approx xyx$		
PB[6,253]	(A)	[111111,111122,111133,112114,121455,123456]	(6,3944)
	$x^2 \approx x^3$	[111111,111122,111133,112114,122455,123456]	(6,3945)
	$xyx \approx x^2yx$	[111111,111122,111133,112124,121455,123456]	(6,3945)
	$xyx \approx xyx^2$	[111111,111122,111133,112124,122455,123456]	(6,3948)
	$xy^2x \approx x^2y^2$		
	$xy^2x \approx y^2x^2$		
	(B)		
	$x^2 \approx x^3$		
	$xyx \approx x^2yx$		
	$xyx \approx xyx^2$		
$x^2y^2 \approx xyxy$			
$xyzxay \approx yxzxay$			
$xyzaxz \approx xyzazx$			

Continued on next page

Table 9 – Continued from previous page

Id	Basis Proposal	Min.Lex	GAP
PB[6,254]	(A) $x^2 \approx x^3$ $xyx \approx yx^2$ $xyxz \approx x^2yz$ (B) $x^2 \approx x^3$ $xyx \approx yx^2$ $x^2yz \approx xyxz$	[111111,111122,111133,112144,123456,123456] [111116,111126,111136,112146,123456,111116]	(6,3950) (6,3839)
PB[6,255]	(A) $x^2 \approx x^4$ $x^2y \approx xyx$ $xy^2 \approx yxy$ (B) $x^2 \approx x^4$ $x^2y \approx xyx$ $x^2y \approx yx^2$	[111111,111122,111133,112144,123456,123465] [111116,111126,111136,112146,123456,666661] [111444,112444,123456,444111,445111,446121] [111444,112444,123456,444111,445111,456111] [111444,112445,123456,444111,445111,446111]	(6,3051) (6,1262) (6,1348) (6,1354) (6,1354)
PB[6,256]	(A) $x^2y \approx x^2y^2$ $xyx \approx xyx^2$ $xy^2 \approx xy^3$ $x^3y \approx x^2yx$ (B) $xyz \approx xyz^2$ $x^3y \approx x^2yx$ $x^3y \approx yx^2y$	[111111,111122,111133,112233,111155,112255]	(6,5441)
PB[6,257]	(A) $x^2y \approx x^2y^2$ $xy^2 \approx xy^3$ $xyx \approx y^3x$ $xyzx \approx xzyx$ (B) $xyz \approx xyz^2$ $xyxz \approx yxyz$	[111111,111122,111133,112233,111156,111156] [111116,111126,111136,112236,111156,111116]	(6,5579) (6,5577)
PB[6,258]	(A) $x^2y \approx x^2y^3$ $xyx \approx x^4y$ $xy^2 \approx xy^4$ $xyx \approx y^3x^2$	[111111,111122,111133,112233,111156,111165] [111116,111126,111136,112236,111156,666661] [111444,112444,113444,444111,445111,445122]	(6,5427) (6,2852) (6,2890)

Continued on next page

Table 9 – Continued from previous page

Id	Basis Proposal	Min.Lex	GAP
PB[6,259]	(A) $xy^2 \approx xy^3$ $x^3y \approx x^2yx$ $xyx^2 \approx x^3y$	[111111,111122,111133,112234,111155,113356]	(6,5595)
PB[6,260]	(A) $x^3 \approx x^4$ $x^3y \approx x^2yx$ $xyx^2 \approx x^3y$	[111111,111122,111133,112234,111155,123456]	(6,5647)
PB[6,261]	(A) $x^3 \approx x^4$ $x^2y \approx xyx$ $xy^3x^2 \approx y^3x^3$	[111111,111122,111133,112244,113355,123456]	(6,5654)
PB[6,262]	(A) $xy^2 \approx xy^3$ $xyxz \approx x^2yz$	[111111,111122,111133,112244,113356,113356] [111116,111126,111136,112246,113356,111116]	(6,5603) (6,5596)
PB[6,263]	(A) $xy^2 \approx xy^4$ $xyz \approx xzy$	[111111,111122,111133,112244,113356,113365] [111116,111126,111136,112246,113356,666661] [111444,112444,113455,444111,445111,446122]	(6,5449) (6,2854) (6,2892)
PB[6,264]	(A) $x^3 \approx x^4$ $yx^2 \approx xyx$ $xyxz \approx x^2yz$	[111111,111122,111133,112244,123456,123456] [111111,111122,111233,111244,123456,123456] [111111,111122,112133,112244,123456,123456] [111116,111126,111136,112246,123456,111116] [111116,111126,111236,111246,123456,111116] [111116,111126,112136,112246,123456,111116]	(6,5676) (6,5675) (6,9461) (6,5648) (6,5642) (6,9442)
PB[6,265]	(A) $x^3 \approx x^5$ $x^2y \approx xyx$ $xy^2 \approx yxy$ (B) $x^3 \approx x^5$ $x^2y \approx xyx$ $x^2y \approx yx^2$	[111111,111122,111133,112244,123456,123465] [111111,111122,111233,111244,123456,123465] [111111,111122,112133,112244,123456,123465] [111116,111126,111136,112246,123456,666661] [111116,111126,111236,111246,123456,666661] [111116,111126,112136,112246,123456,666661] [111444,112444,123456,444111,445111,446122] [111444,112444,123456,444111,445112,446112] [111444,112444,123456,444111,445121,446122]	(6,5461) (6,5461) (6,9379) (6,2860) (6,2860) (6,5303) (6,2896) (6,2896) (6,5317)
PB[6,266]	(A) $x^2 \approx x^3$ $xyx \approx xyx^2$ $x^2y \approx xy^2x$ $x^2yz \approx x^2zy$	[111111,111122,111133,444444,111155,112155] [111111,111122,333333,333344,111155,111255] [111111,111222,111333,111444,111555,112444]	(6,6510) (6,9924) (6,6169)

Continued on next page

CHAPTER 3 - OPEN PROBLEMS

Table 9 – Continued from previous page

Id	Basis Proposal	Min.Lex	GAP
PB[6,267]	(A) $x^2 \approx x^3$ $xyx \approx xyx^2$ $x^2y \approx xy^2x$	[111111,111122,111133,444444,111455,112455]	(6,6512)
PB[6,268]	(Known basis) Lee and Zhang [48, Proposition 23.9]	[111111,111122,111133,444444,113156,133156] [111111,111122,333333,333344,121156,121256] Note: Lee and Zhang [48]	(6,8448) (6,11262)
PB[6,269]	(Known basis) Lee and Zhang [48, Proposition 24.1]	[111111,111122,111133,444444,113456,133456] Note: Lee and Zhang [48]	(6,8453)
PB[6,270]	(A) $x^2 \approx x^4$ $xyx \approx x^3yx$ $xyz^2 \approx xz^2y$	[111111,111122,111133,444444,123156,132165] [111111,111123,111132,444444,123156,123165]	(6,6536) (6,6602)
PB[6,271]	(Known basis) Lee and Li [43, Chapter 10]	[111111,111122,111133,444444,123456,132465] [111111,111123,111132,444444,123456,123465] Note: Lee and Li [43]	(6,6543) (6,6605)
PB[6,272]	(A) $xyz \approx yxz$ $x^4 \approx x^5$	[111111,111122,111233,112344,123456,123456] [111116,111126,111236,112346,123456,111116]	(6,5692) (6,5689)
PB[6,273]	(A) $xy \approx yx$ $x^4 \approx x^6$	[111111,111122,111233,112344,123456,123465] [111116,111126,111236,112346,123456,666661] [111444,112445,123456,444111,445111,456112]	(6,5471) (6,2863) (6,2899)
PB[6,274]	(A) $x^3 \approx x^4$ $xyxz \approx x^2yz$ $xyzx \approx xzyx$ (B) $x^3 \approx x^4$ $x^2yx \approx x^3yx$ $xyza \approx xzya$	[111111,111122,112133,444444,123156,123156] [111116,111226,112336,123446,123556,111116]	(6,9736) (6,9736)
PB[6,275]	(A) $x^3 \approx x^5$ $xyz \approx xzy$	[111111,111122,112133,444444,123156,123165] [111116,111226,112336,123446,123556,666661] [111155,112255,123356,124456,555511,556612]	(6,9595) (6,5740) (6,5754)
PB[6,276]	(Known basis) Lee and Zhang [48, Proposition 24.5]	[111111,111122,112133,444444,123456,123456] Note: Lee and Zhang [48]	(6,9739)

Continued on next page

Table 9 – Continued from previous page

Id	Basis Proposal	Min.Lex	GAP
PB[6,277]	(A) $x^3 \approx x^5$ $x^2y \approx xyx$	[111111,111122,112133,444444,123456,123465]	(6,9597)
PB[6,278]	(Known basis) Lee and Li [43, Chapter 11]	[111111,111122,112233,112244,123456,124365] [111111,111122,112234,112243,123456,123465] Note: Lee and Li [43]	(6,9386) (6,9386)
PB[6,279]	(A) $xy \approx xy^3$ $xyx \approx y^2xyx$	[111111,111122,113434,113443,113456,113465] [111111,112222,113355,113456,113553,113654] [111155,111255,113156,111455,115151,116153] [111155,111255,113356,113456,115551,116653] [111155,122256,122356,122456,155551,166652] [111156,112256,113456,114356,115656,116556] [111444,112445,113446,114441,115442,116443] [111444,122455,123455,144411,155422,156422]	(6,10409) (6,10410) (6,10203) (6,10218) (6,8921) (6,10411) (6,9882) (6,9062)
PB[6,280]	(A) $x^2 \approx x^4$ $xy^2 \approx y^2xy^2$ $xyx \approx xyx^3$	[111111,111122,113434,113443,123456,123465] [111111,111122,123434,123443,123456,123465] [111111,112222,123355,123456,123553,123654] [111155,111255,113156,121455,115151,116153] [111155,111255,113356,123456,115551,116653] [111155,111255,123356,123456,115551,126653] [111155,122256,122356,123456,155551,166652] [111156,112256,123456,124356,115656,116556] [111444,112445,123456,114441,115442,126453] [111444,122455,123456,144411,155422,156422]	(6,11385) (6,11392) (6,11598) (6,10837) (6,10842) (6,11459) (6,8924) (6,11396) (6,9937) (6,9065)
PB[6,281]	(Known basis) Lee and Zhang [48, Proposition 25.5]	[111111,111122,123111,444444,111456,444165] Note: Lee and Zhang [48]	(6,11311)
PB[6,282]	(Known basis) Lee and Zhang [48, Proposition 25.2]	[111111,111122,123122,444444,111456,444165] Note: Lee and Zhang [48]	(6,11312)
PB[6,283]	(A) $x^2 \approx x^3$ $xyx \approx x^2yx$ $xyx \approx xyx^2$ $xyxy \approx xy^2x$ $xyz^2y \approx xzyzy$	[111111,111122,123123,444444,111155,123156] [111111,111122,123323,124424,111155,123356] [111111,111222,123223,111444,111555,123446] [111111,111222,123233,111444,123455,123466]	(6,13356) (6,13385) (6,13420) (6,13612)

Continued on next page

CHAPTER 3 - OPEN PROBLEMS

Table 9 – Continued from previous page

Id	Basis Proposal	Min.Lex	GAP
PB[6,284]	(A)	[111111,111122,123123,444444,111155,123456]	(6,13357)
	$x^2 \approx x^3$	[111111,111122,123123,444444,111455,123456]	(6,13358)
	$xyx \approx x^2yx$	[111111,111122,123123,444444,444455,123456]	(6,13359)
	$xyx \approx xyx^2$	[111111,111122,123323,124424,111155,123456]	(6,13386)
	$xyxy \approx xy^2x$	[111111,111122,123423,444444,111155,123456]	(6,13422)
		[111111,111222,123123,111444,111555,123456]	(6,13413)
		[111111,111222,123223,111444,111555,123456]	(6,13421)
PB[6,285]	(Known basis) Lee and Li [43, Chapter 12]	[111111,111122,123333,124444,123456,124365] Note: Lee and Li [43]	(6,11395)
PB[6,286]	(A)	[111111,111122,123411,123411,111156,111165]	(6,11227)
	$x^2 \approx x^4$	[111111,111122,123411,124311,111156,111156]	(6,11228)
	$xyx \approx y^3x^2$	[111116,111126,123416,123416,111156,666661]	(6,8863)
	$xyzx \approx xzyx$	[111116,111126,123416,124316,111156,111116]	(6,11299)
		[111116,111226,123116,111456,111456,666661]	(6,8856)
		[111116,111226,123116,111456,111546,111116]	(6,10949)
		[111155,112255,113455,114355,111155,121156]	(6,10951)
		[111155,121155,113456,113456,555511,565511]	(6,9009)
		[111155,121156,113455,113455,555511,556611]	(6,9004)
	[111444,112444,113444,111444,121456,121465]	(6,11410)	
PB[6,287]	(A)	[111111,111122,123411,123412,111155,111166]	(6,13403)
	$x^2 \approx x^3$	[111111,111122,123412,123421,111155,111166]	(6,13408)
	$xyx \approx x^2yx$	[111111,111122,123412,123422,111155,111166]	(6,13409)
	$xyx \approx xy^2x$		
	$xyzx \approx xzyx$		
PB[6,288]	(A)	[111111,111122,123411,123422,111156,111165]	(6,11229)
	$x^2 \approx x^4$	[111116,111126,123416,123426,111156,666661]	(6,8864)
	$xyx \approx y^2xyx$		
	$xyzx \approx xzyx$		
PB[6,289]	(A)	[111111,111122,123412,123412,111155,111166]	(6,13404)
	$x^2 \approx x^3$	[111116,111226,123126,111446,111556,111116]	(6,12952)
	$xyx \approx x^2yx$	[111155,112255,113355,114455,111155,121256]	(6,12954)
	$xyzx \approx xzyx$		
	$xyxyz \approx xyxz$		

Continued on next page

Table 9 – Continued from previous page

<b>Id</b>	<b>Basis Proposal</b>	<b>Min.Lex</b>	<b>GAP</b>
PB[6,290]	(A) $x^2 \approx x^4$ $xyx \approx x^3yx$ $xyx \approx xy^3x$ $xyxy \approx xy^2x$ $xyzx \approx xzyx$	[111111,111122,123412,124312,111155,111166] [111116,111226,123126,111446,111556,666661]	(6,11229) (6,8864)
PB[6,291]	(A) $x^2 \approx x^3$ $xyx \approx x^2yx$ $xyx \approx xyx^2$ $xyxy \approx yx^2y$	[111111,111122,123413,123424,111155,123456] [111111,111122,123423,123424,111155,123456] [111111,111222,123223,111454,111455,123456] [111116,111226,123236,111446,123456,111166] [111116,111226,123236,111446,123456,111666] [111116,111226,123236,111446,123456,116166] [111155,112255,113355,123456,111555,122656]	(6,13413) (6,13421) (6,13386) (6,13357) (6,13422) (6,13358) (6,13359)
PB[6,292]	(A) $x^2 \approx x^4$ $xyx \approx y^2xyx$ $xy^2xz \approx xyxyz$	[111111,111122,123422,123422,111156,111165] [111111,111122,123422,124322,111156,111156] [111116,111126,123426,123426,111156,666661] [111116,111126,123426,124326,111156,111116] [111116,111226,123226,111456,111456,666661] [111116,111226,123226,111456,111546,111116] [111155,112255,113455,114355,111155,122256] [111444,112444,113444,111444,122456,122465]	(6,11232) (6,11233) (6,8865) (6,11301) (6,8858) (6,10954) (6,10956) (6,11411)
PB[6,293]	(A) $x^2 \approx x^3$ $xyx \approx x^2yx$ $xyx \approx xyx^2$ $xyxy \approx yx^2y$ $xy^2xz \approx xyxyz$	[111111,111122,123423,123423,111155,123456] [111111,111222,123223,111454,111454,123456] [111111,111222,123233,111444,123456,123456] [111116,111226,123236,111446,123456,111116]	(6,13420) (6,13385) (6,13612) (6,13356)
PB[6,294]	(A) $x^2 \approx x^4$ $xyx \approx x^3yx$ $x^2yx \approx xyx^2$ $xyxy \approx xy^2x$ $xy^2x \approx yxyx$	[111111,111122,123423,124324,111155,123456] [111111,111222,123223,111454,111545,123456] [111111,111222,123233,111444,123456,123465] [111116,111226,123236,111446,123456,666661]	(6,11234) (6,11234) (6,11522) (6,8874)

Continued on next page

Table 9 – Continued from previous page

<b>Id</b>	<b>Basis Proposal</b>	<b>Min.Lex</b>	<b>GAP</b>
PB[6,295]	(A) $x^2 \approx x^4$ $xyx \approx yx^2$ $xy^2xz \approx x^2y^2z$	[111111,111122,123433,123433,123456,123465]	(6,11389)
		[111111,111122,123433,124344,123456,123456]	(6,11237)
		[111116,111126,123436,123436,123456,666661]	(6,8866)
		[111116,111126,123436,124346,123456,111116]	(6,11453)
		[111116,111226,123336,123456,123456,666661]	(6,8877)
		[111116,111226,123336,123456,123546,111116]	(6,11514)
		[111155,122256,123456,123456,555511,556611]	(6,9020)
[111155,122456,123456,122456,555511,556511]	(6,9010)		
PB[6,296]	(Known basis) Lee and Zhang [48, Proposition 26.5]	[111111,111122,333333,444444,111456,114456]	(6,13501)
		[111111,111122,333333,444444,333456,443456] Note: Lee and Zhang [48]	(6,13549)
PB[6,297]	(Known basis) Lee and Zhang [48, Proposition 26.1]	[111111,111122,333333,444444,121456,124456] Note: Lee and Zhang [48]	(6,13527)
PB[6,298]	(Known basis) Lee and Li [43, Chapter 13]	[111111,111123,111132,123444,123456,123465] Note: Lee and Li [43]	(6,6598)
PB[6,299]	(Known basis) Lee and Li [43, Chapter 14]	[111111,111123,111333,123444,123456,123666] Note: Lee and Li [43]	(6,8496)
PB[6,300]	(A) $x^2 \approx x^3$ $xyx \approx xyxyx$ $x^2yx \approx x^2y^2$ $xyx^2 \approx x^2yx$	[111111,111123,123111,444444,111156,156111]	(6,8562)
		[111111,111123,123111,444444,444456,456444]	(6,11276)
PB[6,301]	(Known basis) Lee and Zhang [48, Proposition 27.3]	[111111,111123,333333,123411,111156,666666]	(6,13559)
		[111111,111123,333333,123433,333356,666666] Note: Lee and Zhang [48]	(6,13561)
PB[6,302]	(Known basis) Lee and Zhang [48, Proposition 27.1]	[111111,111123,333333,123423,111156,666666] Note: Lee and Zhang [48]	(6,13560)
PB[6,303]	(Known basis) Lee and Li [43, Chapter 15]	[111111,111123,333333,123441,123456,666666]	(6,13562)
		[111111,111123,333333,123443,123456,666666] Note: Lee and Li [43]	(6,13563)

Continued on next page

Table 9 – Continued from previous page

Id	Basis Proposal	Min.Lex	GAP
PB[6,304]	(A) $x^2y \approx y^2x$ $xyx \approx xyx^2$ $xy^2 \approx xy^3$ (B) $x^2y \approx y^2x$ $xyz \approx xyz^2$	[111111,111222,111333,111444,111444,112445]	(6,5854)
PB[6,305]	(A) $x^2 \approx x^3$ $xyx \approx xyx^2$ $x^2y^2 \approx xyxy$	[111111,111222,111333,111444,112444,121456] [111111,111222,111333,111444,112444,122456]	(6,6432) (6,6439)
PB[6,306]	(A) $x^2 \approx x^3$ $xyx \approx xyx^2$ $x^2y^2 \approx xyxy$ $xyzy \approx xy^2z$	[111111,111222,111333,111444,112445,113446]	(6,6183)
PB[6,307]	(A) $x^2 \approx x^3$ $xyx \approx xyx^2$ $x^2y \approx x^2yx$ $x^2y^2 \approx xyxy$	[111111,111222,111333,111444,112445,123456]	(6,6447)
PB[6,308]	(A) $x^2 \approx x^3$ $xyx \approx xyx^2$ $xy^2x \approx yxyx$ $x^2yz^2 \approx xyxz^2$	[111111,111222,111333,111444,113456,133456]	(6,8276)
PB[6,309]	(A) $x^2 \approx x^4$ $xyx \approx x^3yx$ $x^2y \approx x^2yx^2$ $xy^2x \approx y^2x^2$	[111111,111222,111333,111444,123456,132465]	(6,6598)
PB[6,310]	(A) $x^2 \approx x^3$ $xyx \approx xyx^2$ $x^2y \approx y^2xy$ $x^2yz \approx y^2xz$	[111111,111222,111333,111446,112446,111446] [111116,111226,111336,111446,112446,111116]	(6,6167) (6,6165)

Continued on next page

Table 9 – Continued from previous page

Id	Basis Proposal	Min.Lex	GAP
PB[6,311]	(A)	[111111,111222,111333,111446,112446,111664]	(6,5793)
	$x^2 \approx x^4$	[111111,111222,111333,111455,111544,112544]	(6,5794)
	$xyx \approx xyx^3$	[111116,111226,111336,111446,112446,666661]	(6,3079)
	$x^2y \approx y^3x^2$	[111444,122444,122445,444111,455111,466111]	(6,3141)
PB[6,312]	(A)	[111111,111222,111333,113446,123456,133466]	(6,8496)
	$x^2 \approx x^3$		
	$xyx \approx x^2yx$		
	$xyx \approx xyx^2$		
	$x^2y^2 \approx xyxy$		
	$xy^2x \approx yxyx$		
PB[6,313]	(A)	[111111,111222,111333,113456,113564,113645]	(6,9096)
	$x^2 \approx x^5$	[111111,111222,111333,122456,122564,122645]	(6,9098)
	$xyz \approx xzy$	[111156,111256,111356,113456,555561,666615]	(6,9106)
	$xy^2x \approx y^2x^2$	[111156,111256,111356,122456,555561,666615]	(6,9108)
		[111446,112446,113456,444661,445661,666114]	(6,14978)
		[111446,112446,123446,444661,445661,666114]	(6,14980)
		[113336,123356,336661,346661,356661,661113]	(6,15942)
		[113336,123446,336661,346661,356661,661113]	(6,15944)
	[113355,123356,335511,345511,551133,561133]	(6,15952)	
PB[6,314]	(A)	[111111,111222,112333,123456,123564,123645]	(6,9801)
	$xy \approx yx$	[111156,111256,112356,123456,555561,666615]	(6,9803)
	$x^3 \approx x^6$	[113355,123456,335511,345511,551133,561134]	(6,15956)
PB[6,315]	(A)	[111111,111222,333333,111444,121456,121456]	(6,13654)
	$x^2 \approx x^3$	[111111,111222,333333,111446,121456,111446]	(6,13665)
	$xyx \approx x^2yx$	[111111,112222,113333,114444,123356,123356]	(6,13425)
	$xyxz \approx x^2yz$	[111111,112222,113336,123446,123556,113336]	(6,13398)
	$xyz^2y \approx xz^2y^2$	[111116,112226,113336,114446,123356,111116]	(6,12964)
		[111116,112226,113336,123446,123556,111116]	(6,13363)
PB[6,316]	(A)	[111111,111222,333333,111444,121456,121465]	(6,11514)
	$x^2 \approx x^4$	[111111,111222,333333,111446,121456,111664]	(6,11453)
	$x^2y \approx xyx$	[111111,112222,113333,114444,123356,123365]	(6,11389)
	$xyz^2y \approx xz^2y^2$	[111111,112222,113336,123446,123556,116663]	(6,11237)
		[111116,112226,113336,114446,123356,666661]	(6,8866)
		[111116,112226,113336,123446,123556,666661]	(6,8877)
		[111155,122255,123256,144455,555511,566611]	(6,9010)
		[111155,122255,123356,124456,555511,566611]	(6,9020)

Continued on next page

Table 9 – Continued from previous page

Id	Basis Proposal	Min.Lex	GAP
PB[6,317]	(A)	[111111,111222,333333,111446,121456,111466]	(6,13666)
	$x^2 \approx x^3$	[111111,112222,113336,123446,123556,113666]	(6,13401)
	$xyx \approx x^2yx$	[111116,112226,113336,114446,123356,111166]	(6,12965)
	$xyx \approx xyx^2$	[111116,112226,113336,114446,123356,116666]	(6,13056)
	$xyxzx \approx xyzx$	[111116,112226,113336,123446,123556,111666]	(6,13366)
	$xyz^2y \approx xz^2y^2$	[111116,112226,113336,123446,123556,116666]	(6,13433)
PB[6,318]	(A)	[111111,111222,333333,111456,111564,111645]	(6,14920)
	$xy \approx xy^4$	[111111,111222,333333,333456,333564,333645]	(6,14924)
	$xyz \approx xzy$	[111156,112256,113356,114456,555561,666615]	(6,14934)
		[111446,122446,133446,444661,455661,666114]	(6,15931)
PB[6,319]	(A)	[111111,111222,333333,113456,113564,113645]	(6,14921)
	$xy \approx xy^4$		
	$x^2y \approx xyx$		
PB[6,320]	(A)	[111111,111222,333333,121456,121564,121645]	(6,14922)
	$x^2 \approx x^5$	[111156,112256,123356,124456,555561,666615]	(6,14941)
	$xyz \approx xzy$	[111446,122456,133456,444661,455661,666114]	(6,15934)
PB[6,321]	(A)	[111111,111222,333333,123456,123564,123645]	(6,14923)
	$x^2 \approx x^5$		
	$x^2y \approx xyx$		
PB[6,322]	Inherently non-finitely based	[111111,111223,123131,111446,123456,146161] Note: $B_2^1$	(6,8564)
PB[6,323]	Inherently non-finitely based	[111111,111223,123233,111446,123456,146466] Note: $A_2^1$	(6,13747)
PB[6,324]	(A)	[111111,111223,333333,111456,111456,666666]	(6,13752)
	$xy \approx xy^2$	[111111,111223,333333,333456,333456,666666]	(6,13759)
PB[6,325]	(A)	[111111,111223,333333,111456,111546,666666]	(6,11550)
	$xy \approx xy^3$	[111111,111223,333333,333456,333546,666666]	(6,11554)
	$x^3y \approx x^2yx$		
PB[6,326]	(Known basis) Lee and Zhang [48, Proposition 27.5]	[111111,111223,333333,123456,123456,666666] Note: Lee and Zhang [48]	(6,13755)
PB[6,327]	(A)	[111111,111223,333333,123456,123546,666666]	(6,11552)
	$x^2 \approx x^4$		
	$xyx \approx xyx^3$		
	$x^3y \approx x^2yx$		

Continued on next page

CHAPTER 3 - OPEN PROBLEMS

Table 9 – Continued from previous page

<b>Id</b>	<b>Basis Proposal</b>	<b>Min.Lex</b>	<b>GAP</b>
PB[6,328]	(A)	[111111,112222,113333,123456,123564,123645]	(6,14919)
	$x^2 \approx x^5$	[111111,112222,113356,123456,115563,116635]	(6,14916)
	$x^2y \approx xyx$	[111156,112256,113356,123456,555561,666615]	(6,14939)
	$xy^2x \approx y^2x^2$	[111446,122446,123456,444661,455661,666114]	(6,15929)
PB[6,329]	(A)	[111111,112222,113336,123456,123456,116663]	(6,11236)
	$x^2 \approx x^4$	[111111,112222,113336,123456,123546,113336]	(6,11375)
	$xyx \approx x^3yx$	[111116,112226,113336,123456,123456,666661]	(6,8876)
	$xyxz \approx x^2yz$	[111116,112226,113336,123456,123546,111116]	(6,11370)
	$xy^2x \approx yxyx$	[111116,112226,113356,123456,113356,666661]	(6,8861)
		[111116,112226,113356,123456,115536,111116]	(6,10959)
		[111155,122255,123456,123456,555511,566611]	(6,9019)
	[111155,122455,123456,122455,555511,566611]	(6,9007)	
PB[6,330]	(A)	[111111,112222,113336,123456,123546,113666]	(6,11388)
	$x^2 \approx x^4$	[111116,112226,113336,123456,123546,111666]	(6,11386)
	$xyx \approx xyx^3$	[111116,112226,113336,123456,123546,116666]	(6,11391)
	$xyxy \approx x^2y^2$	[111116,112226,113356,123456,113556,666661]	(6,8862)
	$xy^2x \approx yxyx$	[111116,112226,113356,123456,115536,111616]	(6,10960)
	$xyxzx \approx x^2yzx$	[111116,112226,113356,123456,115536,116666]	(6,10973)
		[111155,122455,123456,124455,555511,566611]	(6,9008)
PB[6,331]	(A)	[111111,112222,113355,123456,113553,123654]	(6,11395)
	$x^2 \approx x^4$		
	$xyx \approx x^3yx$		
	$xyx \approx xyx^3$		
	$xyxy \approx yx^2y$		
PB[6,332]	(A)	[111111,112222,113356,113356,113356,113556]	(6,10298)
	$x^2 \approx x^3$	[111156,111156,111356,111456,111156,151156]	(6,7541)
	$x^2y \approx yxy$	[111156,111256,111256,111456,111156,115156]	(6,7542)
	$xy^2z \approx xyz$	[111156,112256,113356,113356,111156,111556]	(6,10244)
		[111446,112446,113446,111446,111446,111416]	(6,10417)
		[111446,112446,113446,111446,112446,111416]	(6,10418)
		[111446,112446,113446,111466,111466,111466]	(6,10646)
		[111446,112446,113446,111466,112466,111466]	(6,10647)
PB[6,333]	(A)	[111111,112222,113456,114365,115643,116534]	(6,9404)
	$xy \approx xy^5$	[111456,112456,113456,444165,555641,666514]	(6,5325)
	$x^2y \approx xyx$	[113356,123356,331165,341165,556631,665513]	(6,5329)
	$xyx \approx y^5x^2$	[113356,123356,335561,345561,556613,661135]	(6,9336)

Continued on next page

Table 9 – Continued from previous page

Id	Basis Proposal	Min.Lex	GAP
PB[6,334]	(A)	[111111,112222,123356,123356,123356,123556]	(6,11579)
	$x^2 \approx x^3$	[111156,111156,111356,113456,111156,151156]	(6,8221)
	$xyx \approx x^2yx$	[111156,111256,111256,122456,111156,115156]	(6,8226)
	$xy^2z \approx yxyz$	[111156,112256,123356,123356,111156,111556]	(6,11331)
	$xyzzy \approx yxzy$	[111446,112446,123446,111446,111446,111416]	(6,10982)
			[111446,112446,123446,111466,111466,111466]
PB[6,335]	(A)	[111111,112222,123456,124365,125643,126534]	(6,9405)
	$x^2 \approx x^6$	[111456,112456,123456,444165,555641,666514]	(6,5326)
	$xy \approx yx$	[113356,123456,331165,341165,556631,665513]	(6,5330)
		[113356,123456,335561,345561,556613,661135]	(6,9337)
PB[6,336]	(A)	[111111,121116,113151,444444,113151,161112]	(6,14750)
	$x \approx x^3$	[111111,121116,333333,333453,333453,161112]	(6,14769)
	$xyzx \approx xzyx$	[111111,121226,333333,121456,121456,161662]	(6,14679)
		[111111,121226,333333,121456,121546,121226]	(6,14832)
		[111111,121456,333333,121456,151624,151624]	(6,11914)
		[111116,121126,113416,113416,151156,666661]	(6,14626)
		[111116,121126,113416,114316,151156,111116]	(6,14750)
		[111116,122226,123256,144446,123256,666661]	(6,14641)
		[111116,122226,123256,144446,125236,111116]	(6,14832)
		[111116,122256,123356,124456,122256,666661]	(6,14641)
		[111116,122256,123356,124456,155526,111116]	(6,14679)
		[111116,122446,133556,122446,133556,666661]	(6,14654)
		[111116,122446,133556,144226,155336,111116]	(6,11914)
		[111155,121455,333366,121455,555511,666633]	(6,11894)
		[111155,121455,333366,141255,111155,333366]	(6,14813)
	PB[6,337]	(A)	[111111,121116,113451,113451,555555,161112]
$x \approx x^3$		[111111,121116,113451,114351,555555,121116]	(6,14780)
$xyzx \approx x^2yz$		[111111,121226,333333,123456,123456,161662]	(6,14680)
		[111111,121226,333333,123456,123546,121226]	(6,14851)
		[111111,122256,123456,123456,155526,666666]	(6,14689)
		[111111,122256,123456,124356,122256,666666]	(6,14852)
		[111111,123456,123456,145236,145236,666666]	(6,11915)
		[111116,122226,123456,123456,155556,666661]	(6,14651)
		[111116,122226,123456,124356,155556,111116]	(6,14833)
		[111155,123456,123456,444466,555511,666644]	(6,11897)
		[111155,123456,132456,444466,111155,444466]	(6,14814)

Continued on next page

CHAPTER 3 - OPEN PROBLEMS

Table 9 – Continued from previous page

Id	Basis Proposal	Min.Lex	GAP
PB[6,338]	(A) $x \approx x^3$ $xyx^2z \approx xyz$	[111111,121116,113451,444444,445134,121116]	(6,14796)
		[111111,122256,123456,123456,555555,566612]	(6,14690)
		[111111,123456,123456,444444,456123,456123]	(6,11916)
		[111116,122226,123456,144446,145236,111116]	(6,14837)
		[111155,123456,333366,341265,111155,333366]	(6,14817)
PB[6,339]	(A) $x \approx x^3$ $xyz^2 \approx xzyz$	[111111,121226,333333,121456,121546,121666]	(6,14833)
		[111116,121126,113416,114316,151156,116616]	(6,14780)
		[111116,121126,113416,114316,151156,161166]	(6,14762)
		[111116,122226,123256,144446,125236,116166]	(6,14851)
		[111116,122226,123256,144446,125236,166666]	(6,14852)
		[111116,122256,123356,124456,125556,666661]	(6,14651)
		[111116,122256,123356,124456,155526,116616]	(6,14680)
		[111116,122256,123356,124456,155526,166666]	(6,14689)
		[111116,122446,133556,144226,155336,166666]	(6,11915)
		[111155,121455,333366,141255,151555,363666]	(6,14814)
[111456,122456,133456,144456,555614,566614]	(6,11897)		
PB[6,340]	(A) $x \approx x^3$ $x^2yx \approx xyx^2$	[111111,121226,333333,123456,123546,121666]	(6,14872)
		[111111,122256,123456,124356,125556,666666]	(6,14883)
		[111116,122226,123456,124356,155556,116616]	(6,14872)
		[111116,122226,123456,124356,155556,166666]	(6,14883)
		[111155,123456,132456,444466,155155,466466]	(6,14891)
PB[6,341]	(A) $x \approx x^3$ $xy^2zy \approx xzy$	[111111,121255,333333,121456,121552,121654]	(6,14837)
		[111155,121156,113355,114455,151151,161152]	(6,14796)
		[111155,122256,123356,124456,155551,166652]	(6,14690)
		[111444,121446,333555,141441,353553,161442]	(6,14817)
		[111444,122455,133466,144411,155422,166433]	(6,11916)
PB[6,342]	(A) $x \approx x^3$ $xyx^2y \approx x^2yxy$	[111111,121255,333333,123456,121552,123654]	(6,14887)
		[111111,122446,123456,124426,125436,666666]	(6,14888)
		[111444,123456,333555,141441,353553,163452]	(6,14895)
PB[6,343]	(A) $xy \approx x^2y$ $xyzy \approx xzy$	[111111,121256,333333,121256,121256,121556]	(6,14271)
		[111156,111156,113356,114456,111156,151156]	(6,13171)
		[111156,122256,122256,144456,111156,115156]	(6,14465)
		[111446,122446,133446,111446,111446,111416]	(6,13196)
		[111446,122446,133446,111466,111466,111466]	(6,13777)
PB[6,344]	(A) $x \approx x^2$	[111111,121256,333333,123456,126556,666666]	(6,15646)

Continued on next page

Table 9 – Continued from previous page

<b>Id</b>	<b>Basis Proposal</b>	<b>Min.Lex</b>	<b>GAP</b>
PB[6,345]	(A) $x \approx x^5$ $xyz \approx xzy$	[111111,121456,333333,141265,151642,161524] [111456,122456,133456,444165,555641,666514]	(6,9501) (6,9498)
PB[6,346]	(A) $x^2y \approx yxy$ $xy^2 \approx x^2y^2$ $xy^3 \approx xy^2$ (B) $x^2y \approx yxy$ $xyz \approx xy^2z$ $xyz^2 \approx yxz^2$	[111111,122256,122256,122356,122256,122556] [111156,111156,112156,111456,111156,115156] [111156,122256,122256,122356,111156,111556] [111446,111446,112446,111446,111456,114446] [111446,111446,112446,116446,116456,111446]	(6,9753) (6,9699) (6,9787) (6,9700) (6,9702)
PB[6,347]	(A) $xy \approx x^2y$ $xy \approx xyxy$ (B) $xy \approx x^2y$ $xy \approx xyxy$ $xyz^2 \approx xyz^2$	[111111,122456,122456,122456,124456,666666]	(6,14272)
PB[6,348]	(A) $x \approx x^5$ $x^2y \approx xyx$ (B) $x \approx x^5$ $xy \approx x^4yx$	[111111,123456,132465,444444,156432,165423]	(6,9503)
PB[6,349]	(A) $x \approx x^5$ $xyx^2 \approx x^3y$	[111111,123456,132465,444444,456132,465123]	(6,9504)
PB[6,350]	(A) $x \approx x^6$ $xy \approx yx$ (B) $x \approx x^6$ $xy \approx yx$	[111111,123456,134562,145623,156234,162345] [113456,123456,334561,445613,556134,661345]	(6,15960) (6,15961)
PB[6,351]	(A) $x \approx x^4$ $xy^2x \approx xyxy$	[111111,123456,333333,345612,555555,561234]	(6,15903)

Continued on next page

Table 9 – Continued from previous page

Id	Basis Proposal	Min.Lex	GAP
PB[6,352]	(A)	[111116,111116,111116,111126,112246,666661]	(6,910)
	$xy^2 \approx yxy$	[111116,111116,111126,111126,111246,666661]	(6,910)
	$xyz \approx xzy$	[111116,111116,111126,111216,112236,666661]	(6,2570)
	$x^4 \approx y^2z^2$	[111116,111116,111126,111226,112136,666661]	(6,2570)
		[111444,111444,111445,444111,444111,455113]	(6,928)
		[111444,111445,111445,444111,444111,445113]	(6,928)
PB[6,353]	(A)	[111116,111116,111116,111216,113156,111166]	(6,5551)
	$xyx \approx yx^2$	[111116,111116,111116,111216,113356,111166]	(6,5561)
	$xyz \approx yxyz$	[111116,111116,123336,123336,123346,116666]	(6,9638)
	(B)	[111155,111155,112155,111456,111555,111555]	(6,9545)
	$xyx \approx yx^2$ $xyz \approx xy^2z$		
PB[6,354]	(A)	[111116,111116,111116,111416,112116,111616]	(6,3367)
	$x^2 \approx x^3$	[111116,111116,111116,111446,112446,111666]	(6,6161)
	$x^2y \approx xy^2$	[111116,111116,111126,111416,112116,111616]	(6,3622)
	$xyz \approx yxyz$	[111116,111116,111126,111446,111446,111666]	(6,5921)
	(B)	[111116,111116,111126,111446,112446,111666]	(6,6163)
	$x^2 \approx x^3$	[111116,122226,122226,122226,122326,166666]	(6,4008)
	$x^2y \approx xy^2$	[111116,122226,122226,122236,122326,166666]	(6,4010)
	$x^2y \approx yxy$ $xyz \approx x^2yz$	[111155,111155,111155,111455,111555,112555]	(6,6174)
PB[6,355]	(A)	[111116,111116,111116,112116,121456,111166]	(6,3811)
	$x^2 \approx x^3$	[111116,111116,111116,112116,122456,111166]	(6,3824)
	$xyx \approx yx^2$	[111155,111155,111155,113456,111555,131555]	(6,6434)
	$xyz \approx x^2yz$	[111155,111155,111155,122456,111555,112555]	(6,6441)
PB[6,356]	(A)	[111116,111116,111116,113456,133456,666661]	(6,4025)
	$xy \approx x^3y$	[111444,123446,123466,444111,444111,444111]	(6,4240)
	$xyx \approx yx^2$		
	$xyzx \approx xzyx$		
	(B)		
	$xy \approx x^3y$ $xyx \approx yx^2$ $xyzx \approx xzyx$		

Continued on next page

Table 9 – Continued from previous page

Id	Basis Proposal	Min.Lex	GAP
PB[6,357]	(A) $xyz \approx yxz$ $x^2y^2 \approx x^3y$ (B) $xyz \approx yxz$ $x^2yz \approx xyz^2$ $x^5 \approx yzabx$	[111116,111116,111126,111236,112346,111116]	(6,5369)
PB[6,358]	(A) $xy \approx yx$ $xy^3 \approx x^3y$ $x^5 \approx xy^2z^2$ (B) $xy \approx yx$ $x^3y \approx xy^3$ $x^5 \approx xy^2z^2$ $xyzab \approx x^3yzab$	[111116,111116,111126,111236,112346,666661] [111444,111444,112445,444111,444112,445123]	(6,2583) (6,2584)
PB[6,359]	(A) $x^2y \approx xy^2$ $xyx \approx yx^2$ (B) $x^2y \approx xy^2$ $x^2y \approx yxy$ $xyza \approx x^2yza$	[111116,111116,111126,111416,112136,111616] [111116,122226,122226,122236,122346,166666]	(6,5683) (6,5733)
PB[6,360]	(A) $x^2y \approx x^3y$ $xy^2 \approx x^2y^2$ $xyx \approx yxyx$ $xyx^2 \approx yxyx$ (B) $xyx \approx yx^3$ $xyz \approx x^2yz$	[111116,111116,111126,123436,111126,111616]	(6,5636)

Continued on next page

Table 9 – Continued from previous page

Id	Basis Proposal	Min.Lex	GAP
PB[6,361]	(A) $x^2 \approx x^3$ $xyx \approx x^2yx$ $xy^2 \approx x^2y^2$ $xy^2z \approx yxyz$ (B) $x^2 \approx x^3$ $xy^2 \approx xyxy$ $xyz \approx x^2yz$ $xyzx \approx yxzx$	[111116,111116,111126,123446,123446,111666]	(6,6512)
PB[6,362]	(A) $x^2y \approx yxy$ $xy^2 \approx xy^3$ $x^2y^2 \approx x^2y$	[111116,111116,111136,111216,111156,111166] [111116,111116,111136,111236,111156,111166] [111116,112226,113336,113336,113346,116666] [111155,111155,112155,111455,111555,111655]	(6,5527) (6,5532) (6,9643) (6,9539)
PB[6,363]	(A) $x^2y \approx x^3y$ $xyx \approx yx^2$ $x^2yx \approx xyx$ (B) $x^2y \approx x^3y$ $xyx \approx yx^2$ $xyx \approx x^2yx$	[111116,111116,111136,111216,113156,111166] [111116,111116,111136,111236,113356,111166] [111116,112226,123336,123336,123346,116666] [111155,111155,112155,111456,111555,111655]	(6,5553) (6,5563) (6,9657) (6,9546)
PB[6,364]	(A) $x^2y \approx x^3y$ $xyx \approx yx^2$ (B) $x^2y \approx x^3y$ $xyx \approx yx^2$	[111116,111116,111236,111236,123456,111166]	(6,5641)
PB[6,365]	(A) $x^2 \approx x^3$ $xyx \approx x^2yx$ $x^2y^2 \approx xyxy$ $xy^2z \approx xyz$	[111116,111116,111336,121446,121556,111666] [111155,111155,123355,124455,115555,116655]	(6,7659) (6,10620)

Continued on next page

Table 9 – Continued from previous page

<b>Id</b>	<b>Basis Proposal</b>	<b>Min.Lex</b>	<b>GAP</b>
PB[6,366]	(A)	[111116,111116,111336,121456,121456,666661]	(6,4058)
	$x^2 \approx x^4$	[111116,111116,111336,121456,121546,111116]	(6,6222)
	$xyx \approx y^3x^2$	[111155,111155,123455,123455,555511,556611]	(6,4164)
	$xyxz \approx x^2yz$	[111155,112255,113456,113456,555511,555511]	(6,4162)
	(B)	[111155,112255,113456,114356,111155,111155]	(6,9873)
	$x^2 \approx x^4$	[111444,123446,123446,444111,455111,444111]	(6,4270)
PB[6,367]	(A)	[111116,111116,111336,121456,121546,111666]	(6,6225)
	$x^2 \approx x^4$	[111155,111155,123455,124355,115555,116655]	(6,9878)
	$xyx \approx y^3x^2$		
PB[6,368]	(A)	[111116,111116,112116,111446,111556,111666]	(6,9689)
	$x^2y \approx xy^2$	[111116,122226,122226,122326,155556,166666]	(6,9777)
	$xyx \approx x^2yx$		
PB[6,369]	(A)	[111116,111116,112116,111456,111456,666661]	(6,5736)
	$xyz \approx yxz$	[111116,111116,112116,111456,111546,111116]	(6,9531)
	$x^2y \approx y^2x^2y$	[111116,122256,122256,122356,122256,666661]	(6,9649)
PB[6,370]	(A)	[111116,122256,122256,122356,155526,111116]	(6,5744)
	$xy^2 \approx xy^3$	[111116,122446,122446,144226,144236,111116]	(6,5758)
	(B)	[111155,111155,113455,113455,555511,555512]	(6,5750)
	$x^2y \approx xy^2$	[111444,111444,112444,111444,111456,111465]	(6,9551)
	$xyz \approx xzyz$		
	(A)	[111116,111116,112116,111456,111546,111666]	(6,9534)
$xyx \approx yx^2$	[111116,122256,122256,122356,155526,166666]	(6,5746)	
$xyz \approx y^2xyz$	[111116,122446,122446,144226,144236,166666]	(6,5760)	
PB[6,370]	(B)		
	$xy^3 \approx x^3y$		
	$x^2y \approx yx^2y^2$		
PB[6,370]	$xyz \approx x^3yz$		

Continued on next page

CHAPTER 3 - OPEN PROBLEMS

Table 9 – Continued from previous page

<b>Id</b>	<b>Basis Proposal</b>	<b>Min.Lex</b>	<b>GAP</b>
PB[6,371]	(A)	[111116,111116,113456,114536,115346,111116]	(6,14901)
	$xy \approx y^3xy$	[111116,122456,122456,144526,155246,111116]	(6,14954)
	$xyz \approx yxz$	[111116,123356,135526,135526,152236,111116]	(6,15915)
		[111155,123455,134255,142355,111155,111155]	(6,14911)
		[111156,111156,113456,113456,555561,666615]	(6,14930)
		[111156,122456,122456,122456,555561,666615]	(6,14949)
		[111446,123446,123446,444661,444661,666114]	(6,15930)
PB[6,372]	(A)	[111116,111116,113456,114536,115346,116666]	(6,14906)
	$xy \approx y^3xy$	[111116,122456,122456,144526,155246,166666]	(6,14958)
	$xyx \approx yx^2$	[111116,123356,135526,135526,152236,166666]	(6,15920)
PB[6,373]	(B)		
	$xy \approx yxy^3$		
	(A)	[111116,111116,113456,114536,115346,666661]	(6,9112)
	$xy \approx y^7x$	[111116,122456,122456,144526,155246,666661]	(6,11936)
	(B)	[111116,123356,135526,135526,152236,666661]	(6,14986)
	$xy \approx yx$	[111155,123455,134255,142355,555511,555511]	(6,9116)
	$xy \approx x^7y$	[111156,111156,113456,114356,555561,666615]	(6,11931)
		[111156,122456,122456,144256,555561,666615]	(6,9115)
		[111156,123356,132256,132256,555561,666615]	(6,9119)
		[111446,123446,132446,444661,444661,666114]	(6,14987)
PB[6,374]	(A)	[111116,111116,123456,124536,125346,111116]	(6,14920)
	$xy \approx x^4y$	[111155,123456,134256,142356,111155,111155]	(6,14924)
	$xyz \approx yxz$	[111156,111156,123456,123456,555561,666615]	(6,14934)
	(B)	[111446,123456,123456,444661,444661,666114]	(6,15931)
	$xy \approx x^4y$		
	$xyz \approx yxz$		
PB[6,375]	(A)	[111116,111116,123456,124536,125346,116666]	(6,14921)
	$xy \approx x^4y$		
	$xyx \approx yx^2$		
PB[6,376]	(A)	[111116,111116,123456,124536,125346,666661]	(6,9113)
	$xy \approx x^7y$	[111155,123456,134256,142356,555511,555511]	(6,9117)
	$xyx \approx yx^2$	[111156,111156,123456,124356,555561,666615]	(6,11933)
	$xy^2x \approx x^2y^2$	[111446,123456,132456,444661,444661,666114]	(6,14988)
PB[6,377]	(A)	[111116,111126,111136,111246,121456,111166]	(6,5614)
	$x^3 \approx x^4$	[111116,111126,111136,111246,122456,111166]	(6,5622)
	$xy^2x \approx yxyx$	[111116,111126,112236,112246,123356,111166]	(6,9451)
	$xyz^2 \approx xzyz$	[111155,111255,112355,123455,111555,111655]	(6,9582)

Continued on next page

Table 9 – Continued from previous page

Id	Basis Proposal	Min.Lex	GAP
PB[6,378]	(A) $x^2 \approx x^3$ $x^2y \approx yxy$ $x^2y^2 \approx x^2y$	[111116,111126,111136,112116,111156,111166] [111116,111126,111136,112126,111156,111166] [111155,111255,111355,111455,111555,112555]	(6,3373) (6,3378) (6,6177)
PB[6,379]	(A) $x^2 \approx x^3$ $xyx \approx x^2yx$ $xy^2x \approx yxyx$ $x^2yz^2 \approx x^2zyz$ (B) $x^2 \approx x^3$ $xyx \approx x^2yx$ $x^2yz^2 \approx x^2zy^2$ $xyzaxz \approx zxyxaxz$	[111116,111126,111136,112116,121456,111166] [111116,111126,111136,112116,122456,111166] [111116,111126,111136,112126,121456,111166] [111116,111126,111136,112126,122456,111166] [111155,111255,111355,113456,111555,131555] [111155,111255,111355,122456,111555,112555]	(6,3813) (6,3826) (6,3815) (6,3828) (6,6437) (6,6444)
PB[6,380]	(A) $x^2y \approx x^2y^2$ $xy^2 \approx xy^3$ $xyx \approx y^3x$ (B) $xyx \approx yxyx$ $xyz \approx xyz^2$	[111116,111126,111136,112236,111156,111166]	(6,5581)
PB[6,381]	(A) $xy^2 \approx xy^3$ $x^2yx \approx xyx^2$ $xyxy \approx x^2y^2$ (B) $xy^2 \approx xy^3$ $xyz^2 \approx xzy^2$ $x^3y^2 \approx yx^2y^2$	[111116,111126,111136,112246,113356,111166]	(6,5597)

Continued on next page

Table 9 – Continued from previous page

Id	Basis Proposal	Min.Lex	GAP
PB[6,382]	(A)	[111116,111126,111136,113416,121156,111166]	(6,8133)
	$x^2 \approx x^3$	[111116,111126,111136,113416,121156,111616]	(6,8139)
	$xyx \approx xyx^2$	[111116,111126,111316,111416,123156,111166]	(6,7947)
	$xy^2x \approx yxyx$	[111116,111126,111316,111416,123156,111616]	(6,7979)
	$xyxzx \approx xyzx$	[111155,111255,111355,113455,111555,121556]	(6,8158)
	$xyxz^2 \approx xzyxz$	[111155,111255,113155,121456,115155,116155]	(6,11016)
	(B)	[111155,111255,113156,121455,111555,111655]	(6,11066)
	$x^2 \approx x^3$	[111155,111255,123155,111456,111555,111655]	(6,11085)
	$xyx \approx xyx^2$	[111155,111255,123156,111455,115155,116155]	(6,11023)
	$x^2y^2 \approx yx^2y$		
$xyzx \approx yxzx$			
$xyxz^2 \approx xzyxz$			
PB[6,383]	(A)	[111116,111126,111136,113436,121156,111166]	(6,8134)
	$x^2 \approx x^3$	[111116,111126,111136,113436,121156,111616]	(6,8140)
	$xyx \approx xyx^2$	[111116,111126,111316,111416,123356,111166]	(6,7954)
	$xyxy \approx yx^2y$	[111116,111126,111316,111416,123356,111616]	(6,7984)
	$xyzxz \approx xzyxz$	[111155,111255,123255,111456,111555,111655]	(6,11086)
		[111155,111255,123256,111455,115155,116155]	(6,11028)
PB[6,384]	(A)	[111116,111126,111236,112346,123456,111166]	(6,5690)
	$xyx \approx yx^2$		
	$x^4 \approx x^5$		
	(B)		
$xyx \approx yx^2$			
$x^4 \approx x^5$			
PB[6,385]	(A)	[111116,111126,123316,124416,111156,111166]	(6,13407)
	$x^2 \approx x^3$	[111116,111126,123316,124416,111156,116616]	(6,13330)
	$xyx \approx x^2yx$	[111116,111226,123116,111446,111556,111666]	(6,13045)
	$xyx \approx xy^2x$	[111116,111226,123116,111446,111556,116116]	(6,12950)
	$x^2y^2 \approx xyxy$	[111155,112255,113355,114455,115555,125556]	(6,13061)
	(B)	[111155,121155,113356,114456,151155,161155]	(6,13438)
	$x^2 \approx x^3$		
$xyx \approx x^2yx$			
$x^2y^2 \approx xyxy$			
$xyzy \approx xzyzy$			
PB[6,386]	(A)	[111116,111126,123326,124426,111156,111166]	(6,13419)
	$x^2 \approx x^3$	[111116,111126,123326,124426,111156,116616]	(6,13351)
	$xyx \approx x^2yx$	[111116,111226,123226,111446,111556,111666]	(6,13051)
	$xyx^2 \approx yxyx$	[111116,111226,123226,111446,111556,116116]	(6,12959)
	$xyzyz \approx xzyzy$		

Continued on next page

Table 9 – Continued from previous page

Id	Basis Proposal	Min.Lex	GAP
PB[6,387]	(A)	[111116,111126,123416,124316,111156,111166]	(6,11300)
	$x^2 \approx x^4$	[111116,111126,123416,124316,111156,116616]	(6,11306)
	$xyx \approx y^3x^2$	[111116,111226,123116,111456,111546,111666]	(6,10967)
		[111116,111226,123116,111456,111546,116116]	(6,10950)
		[111155,112255,113455,114355,115555,125556]	(6,10976)
		[111155,121155,113456,114356,151155,161155]	(6,11412)
PB[6,388]	(A)	[111116,111126,123426,124326,111156,111166]	(6,11302)
	$x^2 \approx x^4$	[111116,111126,123426,124326,111156,116616]	(6,11307)
	$xyx \approx y^2xyx$	[111116,111226,123226,111456,111546,111666]	(6,10970)
	$x^2yx \approx xyx^2$	[111116,111226,123226,111456,111546,116116]	(6,10955)
PB[6,389]	(A)	[111116,111136,111336,111446,111556,111116]	(6,7184)
	$xy \approx xy^2$	[111155,112255,113355,114455,111155,111255]	(6,10475)
	$xyzx \approx xzyx$		
	(B)		
	$xy \approx xy^2$		
	$x^2yz \approx xyxz$		
	$x^2yz \approx x^2zyz$		
PB[6,390]	(A)	[111116,111136,111336,111446,111556,111666]	(6,7216)
	$xy \approx xy^2$		
	$xyx \approx x^2yx$		
	$x^2yzy \approx x^2zy$		
PB[6,391]	(A)	[111116,111136,111336,111446,111556,666661]	(6,4025)
	$xy \approx xy^3$	[111444,122444,133444,444111,446111,466111]	(6,4240)
	$x^2y \approx xyx$		
	$x^2yz \approx x^2zy$		
PB[6,392]	(A)	[111116,111136,111336,123446,123556,111116]	(6,8448)
	$x^2 \approx x^3$	[111155,112255,123356,124456,111155,111255]	(6,11262)
	$xyx \approx x^2yx$		
	$x^2yz^2 \approx x^2zyz$		
	$xy^2xz \approx x^2y^2z$		
	(B)		
	$x^2 \approx x^3$		
	$xyx \approx x^2yx$		
	$x^2y^2z \approx xy^2xz$		
	$x^2yzy \approx x^2zy^2$		
$xyxzx \approx xzxyx$			

Continued on next page

CHAPTER 3 - OPEN PROBLEMS

Table 9 – Continued from previous page

Id	Basis Proposal	Min.Lex	GAP
PB[6,393]	(A) $x^2 \approx x^3$ $xyx \approx x^2yx$ $x^2yz^2 \approx x^2zyz$ (B) $x^2 \approx x^3$ $xyx \approx x^2yx$ $x^2yzy \approx x^2zy^2$	[111116,111136,111336,123446,123556,111666]	(6,8453)
PB[6,394]	(A) $x^2 \approx x^4$ $xyx \approx x^3yx$ $xy^2x \approx x^2y^2$ $x^2yz^2 \approx x^2zyz$	[111116,111136,111336,123446,123556,666661] [111444,122456,133456,444111,446111,466111]	(6,4091) (6,4297)
PB[6,395]	(A) $x^2 \approx x^3$ $xyx \approx xyx^2$ $x^2y \approx y^2xy$	[111116,111226,111336,111446,112446,111666]	(6,6171)
PB[6,396]	(A) $x^2 \approx x^4$ $xyx \approx x^3yx$ $xyxz \approx x^2yz$ $xy^2x \approx yxyx$ $xyzx \approx xzyx$	[111116,111226,111336,113456,113456,666661] [111116,111226,111336,113456,113546,111116] [111116,111226,111336,122456,122456,666661] [111116,111226,111336,122456,122546,111116] [111155,112255,113456,113456,555511,556611] [111155,112255,123455,123455,555511,556611] [111444,123446,123446,444111,455111,466111] [111444,123455,123455,444111,455111,466111]	(6,4061) (6,6234) (6,4096) (6,6502) (6,4166) (6,4205) (6,4273) (6,4302)
PB[6,397]	(A) $x^2 \approx x^4$ $xyx \approx x^3yx$ $xy^2x \approx yxyx$ $xyz^2 \approx xzyz$ (B) $x^2 \approx x^4$ $xyx \approx x^3yx$ $x^2y^2 \approx yx^2y$ $xyzy \approx xzy^2$	[111116,111226,111336,113456,113546,111666] [111116,111226,111336,122456,122546,111666] [111155,112255,113456,114356,115555,116655]	(6,6239) (6,6506) (6,9880)

Continued on next page

Table 9 – Continued from previous page

Id	Basis Proposal	Min.Lex	GAP
PB[6,398]	(A) $x^2 \approx x^3$ $xyx \approx x^2yx$ $xy^2x \approx yxyx$ $x^2yz^2 \approx xzxyz$	[111116,111226,111336,113456,133456,111666]	(6,8281)
PB[6,399]	(A) $x^2 \approx x^4$ $xyx \approx x^3yx$ $xyxy \approx x^2y^2$ $xy^2x \approx yxyx$ $xyxzx \approx xzxyx$	[111116,111226,111336,113456,133456,666661] [111444,123446,123466,444111,455111,466111]	(6,4091) (6,4297)
PB[6,400]	(A) $x^2 \approx x^4$ $xyx \approx x^3yx$ $xy^2z \approx y^2xz$	[111116,111226,111336,123456,132546,111116] [111116,111236,111326,123456,123546,111116]	(6,6602) (6,6536)
PB[6,401]	(A) $x^2 \approx x^4$ $xy^2 \approx y^2xy^2$ $xyx \approx xyx^3$ $xyxy \approx x^2y^2$ (B) $x^2 \approx x^4$ $xyx \approx xyx^3$ $xy^2 \approx y^2xy^2$	[111116,111226,111336,123456,132546,111666] [111116,111236,111326,123456,123546,111666]	(6,6605) (6,6543)
PB[6,402]	(A) $x^3 \approx x^4$ $xyz^2 \approx xzyz$	[111116,111226,112336,123446,123556,111666]	(6,9739)
PB[6,403]	(A) $x^3 \approx x^5$ $xyz \approx yxz$	[111116,111226,112336,123456,123456,666661] [111116,111226,112336,123456,123546,111116] [111155,112255,123456,123456,555511,556612]	(6,5740) (6,9595) (6,5754)
PB[6,404]	(A) $x^3 \approx x^5$ $xyx \approx yx^2$ (B) $x^3 \approx x^5$ $xyx \approx yx^2$	[111116,111226,112336,123456,123546,111666]	(6,9597)

Continued on next page

Table 9 – Continued from previous page

Id	Basis Proposal	Min.Lex	GAP
PB[6,405]	(A) $x^2 \approx x^3$ $xyx \approx xy^2x$ $xyx^2 \approx xyx$ $xyzxy \approx xzyxy$	[111116,111226,123126,111446,111556,111666] [111116,111226,123126,111446,111556,116116]	(6,13047) (6,12953)
PB[6,406]	(A) $x^2 \approx x^3$ $xyx \approx xyxyx$ $x^2y^2 \approx yx^2y$	[111116,111236,123116,111456,145116,111116] [111444,112445,113446,111444,121454,131464]	(6,8562) (6,11276)
PB[6,407]	(A) $x^2 \approx x^4$ $x^2yx \approx xyx^2$ $xy^2x \approx x^2y^2$	[111116,111236,123116,111456,145116,666661] [111444,121446,113454,444111,454113,446121]	(6,4103) (6,4309)
PB[6,408]	Inherently non-finitely based	[111116,111236,123236,111456,145456,666661] Note: $A_2^g$	(6,8878)
PB[6,409]	(A) $xy \approx xy^4$ $xyx \approx y^4x^2$ $xyxz \approx x^2yz$ (B) $xy \approx xy^4$ $x^2y \approx yx^2y^3$ $x^2yz \approx xyxz$	[111116,112226,113456,114536,115346,111116] [111156,112256,113456,113456,555561,666615] [111446,123446,123446,444661,455661,666114]	(6,14907) (6,14933) (6,15933)
PB[6,410]	(A) $xy \approx xy^4$ $xyx \approx y^4x^2$	[111116,112226,113456,114536,115346,116666]	(6,14910)
PB[6,411]	(A) $xy \approx xy^7$ $x^2y \approx xyx$ $xyx \approx y^7x^2$	[111116,112226,113456,114536,115346,666661] [111155,123455,134255,142355,555511,566611] [111156,112256,113456,114356,555561,666615] [111446,123446,132446,444661,455661,666114]	(6,9113) (6,9117) (6,11933) (6,14988)
PB[6,412]	(A) $x^2 \approx x^5$ $xyz \approx yxz$	[111116,112226,123456,124536,125346,111116] [111156,112256,123456,123456,555561,666615] [111446,123456,123456,444661,455661,666114]	(6,14922) (6,14941) (6,15934)
PB[6,413]	(A) $x^2 \approx x^5$ $xyx \approx yx^2$	[111116,112226,123456,124536,125346,116666]	(6,14923)

Continued on next page

Table 9 – Continued from previous page

Id	Basis Proposal	Min.Lex	GAP
PB[6,414]	(A)	[111116,112226,123456,124536,125346,666661]	(6,9114)
	$x^2 \approx x^8$	[111155,123456,134256,142356,555511,566611]	(6,9118)
	$xy \approx yx$	[111156,112256,123456,124356,555561,666615]	(6,11935)
		[111446,123456,132456,444661,455661,666114]	(6,14989)
PB[6,415]	(A)	[111116,122226,122246,144446,155556,166666]	(6,14272)
	$xy \approx xy^2$ $xy^2 \approx xyxy$		
PB[6,416]	(A)	[111116,122226,123456,144446,145236,116166]	(6,14887)
	$x \approx x^3$	[111116,122226,123456,144446,145236,166666]	(6,14888)
	$xyx^2y \approx xy^2$	[111155,123456,333366,341265,151555,363666]	(6,14895)
PB[6,417]	(A)	[111116,122456,122456,122456,124456,166666]	(6,14270)
	$xy \approx yxy$	[111456,111456,113456,111456,115456,141456]	(6,13172)
		[111456,111456,113456,111456,115456,145456]	(6,13173)
		[111456,122456,122456,111456,114456,166456]	(6,14537)
		[113356,113356,113356,113456,113556,133356]	(6,13197)
		[113356,113356,113356,113456,113556,133556]	(6,13198)
		[113356,113356,153356,153456,113356,153656]	(6,13778)
PB[6,418]	(A)	[111116,122456,122456,122456,124456,666661]	(6,11782)
	$xy \approx y^2xy$	[111156,111156,113456,114356,111156,151156]	(6,11162)
	$xy^3 \approx yxy^2$	[111156,122456,122456,144256,111156,115156]	(6,8932)
		[111156,123356,132256,132256,111156,111556]	(6,9073)
		[111446,123446,132446,111446,111446,111416]	(6,11170)
		[111446,123446,132446,111466,111466,111466]	(6,11602)
PB[6,419]	(A)	[111116,123456,132546,145326,154236,111116]	(6,9501)
	$x \approx x^5$ $xyz \approx yxz$	[111456,123456,123456,444165,555641,666514]	(6,9498)
PB[6,420]	(A)	[111116,123456,132546,145326,154236,166666]	(6,9503)
	$x \approx x^5$ $xyx \approx yx^2$		
PB[6,421]	(A)	[111155,111155,112155,111456,111551,111654]	(6,9535)
	$xyx \approx x^3yx$	[111155,122256,122256,122356,155551,166652]	(6,5747)
	$xy^2 \approx x^3y^2$	[111444,122455,122455,144411,155422,155423]	(6,5761)
	$x^2y \approx y^2x^2y$ $x^2yx \approx yx^3$		
PB[6,422]	(A)	[111155,111155,112155,444466,111155,444466]	(6,9766)
	$x^2y \approx xzy$		

Continued on next page

CHAPTER 3 - OPEN PROBLEMS

Table 9 – Continued from previous page

Id	Basis Proposal	Min.Lex	GAP
PB[6,423]	(A) $x^3 \approx xy^2$ $x^2y \approx xyx$	[111155,111155,112155,444466,555511,666644] [111444,111444,333555,444111,555333,444112]	(6,5496) (6,5507)
PB[6,424]	(A) $x^2 \approx x^4$ $xyx \approx x^3yx$ $x^2yx \approx y^3x^3$	[111155,111255,123156,111455,115151,126153]	(6,11311)
PB[6,425]	(A) $x^2 \approx x^4$ $xyx \approx y^2xyx$ $xyxy \approx yx^2y$	[111155,111255,123256,111455,115151,126253]	(6,11312)
PB[6,426]	(Known basis) $x^2 \approx x^3$ $xyx \approx zyx$	[111156,111156,111156,112156,111156,111556] [111156,111156,111156,112156,111156,115156] [111156,111156,111156,112156,111156,115556] [111156,111156,111256,112156,111156,111556] [111156,111156,111256,112156,111156,115556] [111446,111446,111446,111446,112446,111416] [111446,111446,111446,111446,112446,114416] [111446,111446,111446,111446,112446,114446] [111446,111446,111446,111466,112466,111466] [113336,113346,113366,113366,113366,113366] Note: Website W(6,4)	(6,3557) (6,3393) (6,3558) (6,3625) (6,3626) (6,6172) (6,6187) (6,6188) (6,6180) (6,9884)
PB[6,427]	(A) $x^2 \approx y^3x^2$ $xyz \approx xzy$ (B) $x^2 \approx yx^2y^2$ $xyz \approx xyza^3$	[111156,111156,111156,112156,555561,666615] [113336,113336,336661,336661,346661,661113] [113336,113346,336661,336661,336661,661113] [113355,113355,335511,335511,551133,551233] [122255,255511,255511,256511,511122,511122]	(6,4335) (6,14991) (6,14991) (6,14994) (6,15964)
PB[6,428]	(A) $x^3 \approx y^3$ $xy^2 \approx yxy$ $xyz \approx xzy$	[111156,111156,111156,112256,555561,666615] [111156,111156,111256,111256,555561,666615] [111156,111156,112156,112256,555561,666615] [122255,255511,255511,256611,511122,511122] [122255,255511,255611,255611,511122,511122] [122255,255511,256511,256611,511122,511122]	(6,5763) (6,5763) (6,9506) (6,15968) (6,15968) (6,15971)
PB[6,429]	(A) $x^2 \approx x^2y^3$ $xy \approx yx$	[111156,111156,111256,112156,555561,666615] [113336,113346,336661,336661,346661,661113] [113355,113355,335511,335512,551133,551233] [122255,255511,255611,256511,511122,511122]	(6,4336) (6,14992) (6,14995) (6,15965)

Continued on next page

Table 9 – Continued from previous page

Id	Basis Proposal	Min.Lex	GAP
PB[6,430]	(A) $x^2y \approx yxy$ $x^4 \approx yzx^2$	[111156,111156,111256,112356,111156,111556]	(6,5686)
PB[6,431]	(A) $xy \approx yx$ $x^4 \approx xy^3$	[111156,111156,111256,112356,555561,666615] [113355,113355,335511,335512,551133,551234]	(6,5765) (6,14998)
PB[6,432]	(A) $x^2 \approx x^3$ $xyx \approx yxyx$ $xy^2z \approx xyz$	[111156,111156,111356,121456,111156,151656] [111446,111446,123446,164446,165446,111446] [111446,112446,113456,111446,111446,116416] [111446,112446,113456,114466,114466,114466]	(6,7675) (6,10642) (6,10425) (6,10644)
PB[6,433]	(A) $x^2 \approx x^3$ $xyx \approx x^2yx$ $xyxz \approx y^2xz$	[111156,111156,111356,121456,111556,115156] [111156,111156,111356,121456,111556,115556] [111446,111446,123446,114446,115446,111416] [111446,111446,123446,114446,115446,114416] [111446,112446,113456,161446,161446,116446] [111446,112446,113456,166446,166446,116446]	(6,8219) (6,8220) (6,10980) (6,10981) (6,11118) (6,11119)
PB[6,434]	(A) $x^2 \approx x^3$ $xyx \approx x^2yx$ $xy^2z \approx yxyz$	[111156,111156,111356,123456,111156,151656] [111156,111256,111256,123456,111156,115656] [111446,111446,123456,164446,165446,111446] [111446,112446,123456,111446,111446,116416] [111446,112446,123456,111446,112446,116416] [111446,112446,123456,114466,114466,114466]	(6,8232) (6,8233) (6,11124) (6,10988) (6,10989) (6,11126)
PB[6,435]	(A) $xy \approx xy^2$ $xyxzy \approx xzy$	[111156,111156,113356,114456,111656,116656] [111156,122256,122256,144456,111656,166656] [111446,122446,133446,116446,116446,166446]	(6,12198) (6,14467) (6,12526)
PB[6,436]	(A) $xy \approx x^2y$	[111156,111156,123356,124456,111156,156656] [111446,122456,133456,111446,111446,166416]	(6,13752) (6,13759)
PB[6,437]	(A) $xy \approx x^2y$ $xyxzy \approx xzy^2$	[111156,111156,123356,124456,111656,116656] [111446,122456,133456,116446,116446,166446]	(6,13501) (6,13549)
PB[6,438]	(A) $xy \approx x^3y$ $xyx^2 \approx yx^3$	[111156,111156,123456,124356,111156,156656] [111446,123456,132456,111446,111446,166416]	(6,11550) (6,11554)

Continued on next page

CHAPTER 3 - OPEN PROBLEMS

Table 9 – Continued from previous page

Id	Basis Proposal	Min.Lex	GAP
PB[6,439]	(A) $x^2 \approx x^3$ $xyx \approx x^2yx$ $xyxy \approx yx^2y$ $xyz^2y \approx xzy^2$	[111156,111256,111356,113456,111556,115656] [111156,111256,111356,122456,111556,155656] [111446,112446,113456,114446,115446,116416] [111446,112446,113456,114466,115466,116466]	(6,7676) (6,8500) (6,10426) (6,10643)
PB[6,440]	(A) $x^2 \approx x^3$ $xyx \approx x^2yx$ $xyz^2x \approx zyxzx$	[111156,111256,111356,113456,111556,151156] [111156,111256,111356,113456,111556,151556] [111156,111256,111356,122456,111556,115156] [111156,111256,111356,122456,111556,115556] [111446,112446,113456,114446,115446,141446] [111446,112446,113456,114446,115446,144446]	(6,8222) (6,8223) (6,8227) (6,8228) (6,10984) (6,10983)
PB[6,441]	(A) $x^3 \approx x^4$ $x^2yx \approx x^3yx$ $xyx^2 \approx yx^3$	[111156,111256,112356,123456,111556,115656]	(6,9726)
PB[6,442]	(A) $x^2 \approx x^3$ $xyx \approx yxyx$ $x^2y^2 \approx yxy^2$	[111156,111256,123156,111456,111556,156156] [111446,112446,113446,114446,124456,144466]	(6,13559) (6,13561)
PB[6,443]	(A) $x^2 \approx x^3$ $xyx \approx yxyx$	[111156,111256,123256,111456,111556,156556]	(6,13560)
PB[6,444]	(A) $xy \approx xy^2$ $xyxzy \approx x^2zy$	[111156,112256,113356,114456,111656,116656]	(6,12399)
PB[6,445]	(A) $x^2 \approx x^3$ $xyx \approx x^2yx$ $xyzy \approx xz^2y$	[111156,112256,113356,114456,115556,151156] [111156,112256,113356,114456,115556,155556]	(6,13184) (6,13188)
PB[6,446]	(A) $x^2 \approx x^3$ $xyx \approx x^2yx$ $x^2y \approx xyxy$	[111156,112256,113356,114456,115556,151556]	(6,13185)
PB[6,447]	(A) $x^2 \approx x^3$ $xyx \approx x^2yx$ $xyxy \approx yx^2y$	[111156,112256,113356,123456,115556,151656] [111156,112256,113356,123456,115556,155656]	(6,13562) (6,13563)

Continued on next page

Table 9 – Continued from previous page

<b>Id</b>	<b>Basis Proposal</b>	<b>Min.Lex</b>	<b>GAP</b>
PB[6,448]	(A) $x^2 \approx x^4$ $xyx \approx x^3yx$ $x^3y \approx y^2xy$	[111156,112256,113456,114356,115556,151156] [111156,112256,113456,114356,115556,155556]	(6,11165) (6,11166)
PB[6,449]	(A) $x^2 \approx x^3$ $xyx \approx x^2yx$ $x^2yz^2 \approx xzxyz$ $xyxz^2 \approx xzyxz$	[111156,112256,123356,124456,111656,116656]	(6,13527)
PB[6,450]	(A) $x^2 \approx x^3$ $xyx \approx x^2yx$	[111156,112256,123356,124456,115556,156656]	(6,13755)
PB[6,451]	(A) $x^2 \approx x^4$ $xyx \approx x^3yx$ $xyx^2 \approx yx^3$ $xyxy \approx yx^2y$	[111156,112256,123456,124356,115556,156656]	(6,11552)
PB[6,452]	(A) $x \approx x^2$ $xyxzy \approx yzxy$	[111156,122256,123456,144456,115656,166656]	(6,15646)
PB[6,453]	(A) $x \approx x^5$ $x^2yx \approx yx^3$	[111444,123456,132465,144411,156432,165423]	(6,9504)
PB[6,454]	(A) $x \approx x^3$	[111444,123456,333555,141441,353553,361542]	(6,14897)
PB[6,455]	(A) $x^2y \approx yxy$ $xy^2 \approx zxy^2$	[111456,111456,112456,111456,114456,145456]	(6,9727)
PB[6,456]	(A) $x^3 \approx y^2x$ $xyz \approx yxz$	[111456,111456,112456,111456,555614,555614] [113356,113356,331165,331265,113356,331165]	(6,5496) (6,5507)
PB[6,457]	(A) $xy \approx yx$ $x^3 \approx x^3y^4$	[111456,111456,112456,444165,555641,666514] [113356,113356,331165,331265,556631,665513] [122446,211664,211664,466221,466231,644112]	(6,5113) (6,5114) (6,5115)
PB[6,458]	(A) $x \approx x^4$ $xy^2x \approx yxyx$	[113355,123456,133551,143652,153153,163254]	(6,15903)

Continued on next page

CHAPTER 3 - OPEN PROBLEMS

Table 9 – Continued from previous page

Id	Basis Proposal	Min.Lex	GAP
PB[6,459]	(A) $x \approx xy^3$ $xy \approx xzyz^2$	[113355,224466,335511,446622,551133,662244]	(6,15959)
PB[6,460]	(A) $xy \approx yxz^5$	[113456,113456,334561,445613,556134,661345] [122456,244561,244561,455612,566124,611245]	(6,14999) (6,15973)
PB[6,461]	(A) $x \approx y^3x$ $xy \approx zxz^2y$	[123456,123456,345612,345612,561234,561234]	(6,15959)
PB[6,462]	(Known basis) $x \approx y^6x$ $xy \approx yx$	[123456,214365,345612,436521,561234,652143] Note: Website W(6,5)	(6,14996)
PB[6,463]	(A) $x \approx y^6x$ $x^2 \approx x^2y^6$	[123456,214365,351624,462513,536142,645231]	(6,4337)

## 4 Conclusions

### 4.1 Contributions

For this thesis, I successfully implemented a website that represents an important step in the study of semigroup varieties, by:

- For the first time gathering previously sparse information about all known varieties generated by semigroups up to order 5 and presenting it in a website, in a visual appealing and user friendly way;
- Designing and implementing several algorithms for manipulation and visualisation of semigroups and varieties, optimized for performance and responsiveness, providing a better user experience in the site;
- Integrating, in a transparent way to the user, the Prover9/Mace4 automatic theorem prover in several of these algorithms, along with the development of cache techniques using memory and a relational database, for increased speed of operations.

Other innovative work under this thesis was the usage of computational algebra and automatic theorem proving to extend the database of varieties.

Within this extremely challenging objective, a new methodology (with 2 different sub-algorithms) was developed to identify the new varieties and produce conjectures for the respective identity basis.

With this new methodology, the 2035 semigroups of order 6 which varieties do not coincide with the known varieties generated by semigroups up to order 5, were divided into 463 sets of semigroups that satisfies the same identities.

To test all aimed identities would be virtually impossible using current computer systems, but a number of techniques were developed to greatly limit the calculations needed, and also to reduce the usage of the automatic theorem prover Prover9/Mace4 only to the very last steps of the process, with the objective to further narrow the remaining list of candidate identities to form the conjectured basis.

From the 463 semigroup sets identified, 5 sets corresponds to known varieties generated by semigroups of order 6 registered in this site database (varieties (6, 1) to (6, 5)), 40 other varieties are known ([12, 37, 43, 48]) (soon to be inserted into the database) and 4 are the non-finitely based varieties generated by semigroups of order 6. For the remaining 414 sets, this work proposes the same number of new candidate varieties, and presents conjectures for all the basis of these new varieties generated by semigroups of order 6, or at least a subset of it.

### 4.2 Limitations

Since the aim was to develop a website, not all algorithms can be used on it, due the length of the processing time.

For instance, one of the algorithms used to find a conjecture for the basis of a variety generated by a semigroup of order 6 can, for some semigroups, take only a few seconds to finish, but for other semigroups will take up to 10 minutes on an average

personal computer. The second developed algorithm dedicated to this task can take much more time: days in the worst cases (but with the potential to yield better results in certain cases).

Due to this, these algorithms are not suitable to be available on the web site, they are run in a command line in the operating system.

Additionally, some of the algorithms available in the web are limited by parametrization to maximum input values. For instance, the calculation of the representative in the isomorphism class of  $S$ , whose vector  $S$  is lexicographically the least, is limited to order 10, with aim of delivering a sub-second response. In another example, the identification of the variety of a semigroup is limited to order 100 semigroup, also for performance reasons.

### 4.3 Future work

Many ideas were left for the future due to lack of time. In fact many of these ideas are already under development and can integrate the website in the near future, or take of a life of its own under the form of a specific tool. Some of these ideas are:

- Increase functionality of the site by interfacing it with the GAP system;
- Write a GAP package that does everything the website offers. This will permit the software to be controlled by the command line and hence the user can carry large number of batch operations;
- Optimize the current algorithms, namely on cpu and memory usage, to speed up order 6 variety search, and continue variety search to order 7 and upper;
- Optimize the current algorithms to propose for the new varieties, not only the identities integrating the basis, but also the identities defining maximal subvarieties;
- Automate the needed proofs for new varieties;
- Within the website, offer a platform for anyone to contribute to the database of semigroup varieties;
- Increase the website functionality dedicated to groups (during these work 2 group function libraries were developed, but there was not enough time to build the user interface to those functions);
- Design a new lexicographical minimum algorithm, to cover much higher orders with sufficient speed to be used on the website.

## References

- [1] J. Almeida, *Finite Semigroups and Universal Algebra*, World Scientific, Singapore, 1994.
- [2] J. Araújo, J. P. Araújo, P. J. Cameron, E. W. H. Lee, J. Raminhos, A survey on varieties generated by  $s$  small semigroups and a companion website, <http://arxiv.org/abs/1911.05817>.
- [3] A. P. Birjukov, Varieties of idempotent semigroups, *Algebra and Logic* **9** (1970), no. 3, 153–164; translation of *Algebra i Logika* **9** (1970), no. 3, 255–273.
- [4] G. Birkhoff, *Lattice Theory*, Amer. Math. Soc, Coll. Publ. Vol. 25, (3rd. edition, 3rd printing), Providence, RI, 1979.
- [5] S. M. Bogdanović, M. D. Ćirić, and Z. L. Popović, *Semilattice Decompositions of Semigroups*, Faculty of Economics, University of Niš, 2011.
- [6] S. Bogdanović and M. Ćirić, Orthogonal sums of semigroups, *Israel J. Math.* **90** (1995), no. 1–3, 423–428.
- [7] S. Burris and H. P. Sankappanavar, *A Course in Universal Algebra*, Springer Verlag, New York, 1981.
- [8] J. Cossey and S. O. Macdonald, A basis for the laws of  $\text{PSL}(2, 5)$ , *Bull. Amer. Math. Soc.* **74** (1968), no. 3, 602–606.
- [9] J. Cossey, S. O. Macdonald, and A. P. Street, On the laws of certain finite groups, *J. Austral. Math. Soc.* **11** (1970), no. 4, 441–489.
- [10] C. C. Edmunds, On certain finitely based varieties of semigroups, *Semigroup Forum* **15** (1977), no. 1, 21–39.
- [11] C. C. Edmunds, Varieties generated by semigroups of order four, *Semigroup Forum* **21** (1980), no. 1, 67–81.
- [12] C. C. Edmunds, E. W. H. Lee, and K. W. K. Lee, Small semigroups generating varieties with continuum many subvarieties, *Order* **27** (2010), no. 1, 83–100.
- [13] T. Evans, The lattice of semigroup varieties, *Semigroup Forum* **2** (1971), no. 1, 1–43.
- [14] C. F. Fennemore, All varieties of bands. I, II, *Math. Nachr.* **48** (1971), no. 1–6, 237–252; *ibid.* **48** (1971), no. 1–6, 253–262.
- [15] J. A. Gerhard, The lattice of equational classes of idempotent semigroups, *J. Algebra* **15** (1970), no. 2, 195–224.
- [16] J. A. Gerhard and M. Petrich, All varieties of regular orthogroups, *Semigroup Forum* **31** (1985), no. 3, 311–351.

## BIBLIOGRAPHY

- [17] J. A. Gerhard and M. Petrich, Varieties of bands revisited, *Proc. London Math. Soc.* (3) **58** (1989), no. 2, 323–350.
- [18] È. A. Golubov and M. V. Sapir, Varieties of finitely approximable semigroups, *Soviet Math. (Iz. VUZ)* **26** (1982), no. 11, 25–36; translation of *Izv. Vyssh. Uchebn. Zaved. Mat.* 1982, no. 11, 21–29.
- [19] G. Higman, Some remarks on varieties of groups, *Quart. J. Math. Oxford* (2) **10** (1959), no. 1, 165–178.
- [20] J. M. Howie, *Fundamentals of Semigroup Theory*, Oxford University Press, New York, 1995.
- [21] S. V. Ivanov and A. M. Storozhev, On varieties of groups in which all periodic groups are abelian, *Group theory, statistics, and cryptography*, 55–62, *Contemp. Math.* **360**, Amer. Math. Soc., Providence, RI, 2004.
- [22] M. Jackson, Finite semigroups whose varieties have uncountably many subvarieties, *J. Algebra* **228** (2000), no. 2, 512–535.
- [23] M. Jackson, Small inherently nonfinitely based finite semigroups, *Semigroup Forum* **64** (2002), no. 2, 297–324.
- [24] M. Jackson, Finite semigroups with infinite irredundant identity bases, *Internat. J. Algebra Comput.* **15** (2005), no. 3, 405–422.
- [25] M. Jackson, Syntactic semigroups and the finite basis problem, in V. B. Kudryavtsev *et al.* (eds.), *Structural Theory of Automata, Semigroups, and Universal Algebra*, 159–167, NATO Sci. Ser. II Math. Phys. Chem., 207, Springer, Dordrecht, 2005.
- [26] C. O. Kiselman, A semigroup of operators in convexity theory, *Trans. Amer. Math. Soc.* **354** (2002), no. 5, 2035–2053.
- [27] L. G. Kovács, Free groups in a dihedral variety, *Proc. Roy. Irish Acad. Sect. A* **89** (1989), no. 1, 115–117.
- [28] L. G. Kovács and M. F. Newman, Cross varieties of groups, *Proc. Roy. Soc. Ser. A* **292** (1966), 530–536.
- [29] P. A. Kozhevnikov, On nonfinitely based varieties of groups of large prime exponent, *Comm. Algebra* **40** (2012), no. 7, 2628–2644.
- [30] E. W. H. Lee, Identity bases for some non-exact varieties, *Semigroup Forum* **68** (2004), no. 3, 445–457.
- [31] E. W. H. Lee, Subvarieties of the variety generated by the five-element Brandt semigroup, *Internat. J. Algebra Comput.* **16** (2006), no. 2, 417–441.
- [32] E. W. H. Lee, Minimal semigroups generating varieties with complex subvariety lattices, *Internat. J. Algebra Comput.* **17** (2007), no. 8, 1553–1572.

- [33] E. W. H. Lee, On the complete join of permutative combinatorial Rees–Sushkevich varieties, *Int. J. Algebra* **1** (2007), no. 1–4, 1–9.
- [34] E. W. H. Lee, Combinatorial Rees–Sushkevich varieties are finitely based, *Internat. J. Algebra Comput.* **18** (2008), no. 5, 957–978.
- [35] E. W. H. Lee, On the variety generated by some monoid of order five, *Acta Sci. Math. (Szeged)* **74** (2008), no. 3–4, 509–537.
- [36] E. W. H. Lee, Hereditarily finitely based monoids of extensive transformations, *Algebra Universalis* **61** (2009), no. 1, 31–58.
- [37] E. W. H. Lee, Combinatorial Rees–Sushkevich varieties that are Cross, finitely generated, or small, *Bull. Aust. Math. Soc.* **81** (2010), no. 1, 64–84.
- [38] E. W. H. Lee, Finite basis problem for 2-testable monoids, *Cent. Eur. J. Math.* **9** (2011), no. 1, 1–22.
- [39] E. W. H. Lee, Varieties generated by 2-testable monoids, *Studia Sci. Math. Hungar.* **49** (2012), no. 3, 366–389.
- [40] E. W. H. Lee, Finite basis problem for semigroups of order five or less: generalization and revisitation, *Studia Logica* **101** (2013), no. 1, 95–115.
- [41] E. W. H. Lee, A class of finite semigroups without irredundant bases of identities, *Yokohama Math. J.* **61** (2015), 1–28.
- [42] E. W. H. Lee, Variety membership problem for two classes of non-finitely based semigroups, *Wuhan Univ. J. Nat. Sci.* **23** (2018), no. 4, 323–327.
- [43] E. W. H. Lee and J. R. Li, Minimal non-finitely based monoids, *Dissertationes Math. (Rozprawy Mat.)* **475** (2011), 65 pp.
- [44] E. W. H. Lee, J. R. Li, and W. T. Zhang, Minimal non-finitely based semigroups, *Semigroup Forum* **85** (2012), no. 3, 577–580.
- [45] E. W. H. Lee, J. Rhodes, and B. Steinberg, Join irreducible semigroups, *Internat. J. Algebra Comput.* **29** (2019), no. 7, 1249–1310.
- [46] E. W. H. Lee and M. V. Volkov, On the structure of the lattice of combinatorial Rees–Sushkevich varieties, in J.M. André *et al.* (eds.), *Semigroups and Formal Languages*, 164–187, World Scientific, 2007.
- [47] E. W. H. Lee and M. V. Volkov, Limit varieties generated by completely 0-simple semigroups, *Internat. J. Algebra. Comput.* **21** (2011), no. 1–2, 257–294.
- [48] E. W. H. Lee and W. T. Zhang, Finite basis problem for semigroups of order six, *LMS J. Comput. Math.* **18** (2015), no. 1, 1–129.
- [49] Y. F. Luo and W. T. Zhang, On the variety generated by all semigroups of order three, *J. Algebra* **334** (2011), 1–30.

## BIBLIOGRAPHY

- [50] E. S. Lyapin, *Semigroups*, Translations of Mathematical Monographs, Vol. 3, American Mathematical Society, Providence, RI, 1974.
- [51] S. A. Malyshev, Permutational varieties of semigroups whose lattice of subvarieties is finite (in Russian), in *Modern Algebra*, 71–76, Leningrad. Univ., Leningrad, 1981.
- [52] R. McKenzie, Tarski’s finite basis problem is undecidable, *Internat. J. Algebra Comput.* **6** (1996), no. 1, 49–104.
- [53] R. N. McKenzie, G. F. McNulty, and W. F. Taylor, *Algebras, Lattices, Varieties. I*, Wadsworth and Brooks/Cole, Monterey, CA, 1987.
- [54] I. I. Mel’nik, A description of certain lattices of varieties of semigroups (in Russian), *Izv. Vyssh. Uchebn. Zaved. Mat.* 1972, no. 7, 65–74.
- [55] V. H. Mikaelian, Metabelian varieties of groups and wreath products of abelian groups, *J. Algebra* **313** (2007), no. 2, 455–485.
- [56] B. H. Neumann, Identical relations in groups. I, *Math. Ann.* **114** (1937), no. 1, 506–525.
- [57] H. Neumann, *Varieties of Groups*, Springer, New York, 1967.
- [58] S. Oates and M. B. Powell, Identical relations in finite groups, *J. Algebra* **1** (1964), no. 1, 11–39.
- [59] P. Perkins, Bases for equational theories of semigroups, *J. Algebra* **11** (1969), no. 2, 298–314.
- [60] M. Petrich, All subvarieties of a certain variety of semigroups, *Semigroup Forum* **7** (1974), no. 1–4, 104–152.
- [61] G. Pollák, On two classes of hereditarily finitely based semigroup identities, *Semigroup Forum* **25** (1982), no. 1–2, 9–33.
- [62] M. Petrich and N. R. Reilly, *Completely Regular Semigroups*, Wiley & Sons, New York, 1999.
- [63] M. V. Sapir, Inherently non-finitely based finite semigroups, *Math. USSR-Sb.* **61** (1988), no. 1, 155–166; translation of *Mat. Sb. (N.S.)* **133** (1987), no. 2, 154–166.
- [64] M. V. Sapir, Problems of Burnside type and the finite basis property in varieties of semigroups, *Math. USSR-Izv.* **30** (1988), no. 2, 295–314; translation of *Izv. Akad. Nauk SSSR Ser. Mat.* **51** (1987), no. 2, 319–340.
- [65] M. V. Sapir, On Cross semigroup varieties and related questions, *Semigroup Forum* **42** (1991), no. 3, 345–364.
- [66] M. V. Sapir, *Combinatorial Algebra: Syntax and Semantics*, Springer Monographs in Mathematics, Springer, Cham, 2014.

- [67] M. V. Sapir and E. V. Suhanov, Varieties of periodic semigroups (in Russian), *Izv. Vyssh. Uchebn. Zaved. Mat.* 1981, no. 4, 48–55.
- [68] L. N. Shevrin, Semigroups with certain types of subsemigroup lattices (in Russian), *Dokl. Akad. Nauk SSSR* **138** (1961), no. 4, 796–798.
- [69] L. N. Shevrin, Epigroups, in V. B. Kudryavtsev *et al.* (eds.), *Structural Theory of Automata, Semigroups, and Universal Algebra*, 331–380, NATO Sci. Ser. II Math. Phys. Chem., 207, Springer, Dordrecht, 2005.
- [70] L. N. Shevrin, B. M. Vernikov, and M. V. Volkov, Lattices of semigroup varieties, *Russian Math. (Iz. VUZ)* **53** (2009), no. 3, 1–28; translation of *Izv. Vyssh. Uchebn. Zaved. Mat.* 2009, no. 3, 3–36.
- [71] A. L. Šmel'ken, Wreath products and varieties of groups, *Soviet Math. Dokl.* **5** (1964), 1099–1101; translation of *Dokl. Akad. Nauk SSSR* **157** (1964), no. 5, 1063–1065.
- [72] B. Southcott, A basis for the laws of a class of simple groups, *J. Austral. Math. Soc.* **17** (1974), no. 4, 500–505.
- [73] T. Tamura, The theory of constructions of finite semigroups I., *Osaka Math. J.* **8** (1956), no. 2, 243–261.
- [74] T. Tamura, Remark on the smallest semilattice congruence, *Semigroup Forum* **5** (1972), no. 1, 277–282.
- [75] A. Tarski, Equational logic and equational theories of algebras, in H. A. Schmidt *et al.* (eds.), *Contributions to Math. Logic* (Hannover, 1966), 275–288, North-Holland, Amsterdam, 1968.
- [76] A. V. Tishchenko, The finiteness of a base of identities for five-element monoids, *Semigroup Forum* **20** (1980), no. 2, 171–186.
- [77] A. V. Tishchenko, The wreath product of atoms of the lattice of semigroup varieties, *Trans. Moscow Math. Soc.* 2007, 93–118; translation of *Tr. Mosk. Mat. Obs.* **68** (2007), 107–132.
- [78] A. V. Tishchenko, On the lattice of subvarieties of the wreath product of the variety of semilattices and the variety of semigroups with zero multiplication, *J. Math. Sci. (N.Y.)* **221** (2015), no. 3, 436–451; translation of *Fundam. Prikl. Mat.* **19** (2014), no. 6, 191–212.
- [79] A. N. Trahtman, A basis of identities of the five-element Brandt semigroup (in Russian), *Ural. Gos. Univ. Mat. Zap.* **12** (1981), no. 3, 147–149.
- [80] A. N. Trahtman, The finite basis question for semigroups of order less than six, *Semigroup Forum* **27** (1983), no. 1–4, 387–389.
- [81] A. N. Trahtman, Some finite infinitely basable semigroups (in Russian), *Ural. Gos. Univ. Mat. Zap.* **14** (1987) no. 2, 128–131.

## BIBLIOGRAPHY

- [82] A. N. Trahtman, Finiteness of identity bases of five-element semigroups (in Russian), in E. S. Lyapin (ed.), *Semigroups and Their Homomorphisms*, 76–97, Ross. Gos. Ped. Univ., Leningrad, 1991.
- [83] A. N. Trahtman, Identities of a five-element 0-simple semigroup, *Semigroup Forum* **48** (1994), no. 3, 385–387.
- [84] B. M. Vernikov, Varieties of semigroups whose lattice of subvarieties is decomposable into a direct product (in Russian), *Ural. Gos. Univ. Mat. Zap.* **14** (1988), no. 3, 41–52.
- [85] B. M. Vernikov, On modular elements of the lattice of semigroup varieties, *Comment. Math. Univ. Carolin.* **48** (2007), no. 4, 595–606.
- [86] B. M. Vernikov, Special elements in lattices of semigroup varieties, *Acta Sci. Math. (Szeged)* **81** (2015), no. 1–2, 79–109.
- [87] B. M. Vernikov and M. V. Volkov, Lattices of nilpotent varieties of semigroups. II (in Russian), *Izv. Ural. Gos. Univ. Mat. Mekh.* 1(10) (1998), 13–33.
- [88] M. V. Volkov, The finite basis problem for finite semigroups: a survey, in P. Smith *et al.* (eds.), *Semigroups* (Braga, 1999), 244–279, World Sci. Publ., River Edge, NJ, 2000.
- [89] M. V. Volkov, The finite basis problem for finite semigroups, *Sci. Math. Jpn.* **53** (2001), no. 1, 171–199.
- [90] M. V. Volkov, On a question by Edmond W. H. Lee, *Izv. Ural. Gos. Univ. Mat. Mekh.* No. 7(36) (2005), 167–178.
- [91] M. V. Volkov and I. A. Gol'dberg, Identities of semigroups of triangular matrices over finite fields, *Math. Notes* **73** (2003), no. 4, 474–481; translation of *Mat. Zametki* **73** (2003), no. 4, 502–510.
- [92] P. M. Weichsel, A decomposition theory for finite groups with applications to  $p$ -groups, *Trans. Amer. Math. Soc.* **102** (1962), no. 2, 218–226.
- [93] W. T. Zhang and Y. F. Luo, The subvariety lattice of the join of two semigroup varieties, *Acta Math. Sin. (Engl. Ser.)* **25** (2009), no. 6, 971–982.
- [94] W. T. Zhang and Y. F. Luo, A new example of a minimal non-finitely based semigroup, *Bull. Aust. Math. Soc.* **84** (2011), no. 3, 484–491.
- [95] The GAP Group, GAP – Groups, Algorithms, and Programming, Version 4.8.6; 2016. <http://www.gap-system.org>
- [96] <http://www.cs.st-andrews.ac.uk/?q=node/162>
- [97] The On-Line Encyclopedia of Integer Sequences, 2010, <http://oeis.org>
- [98] <http://www.cs.unm.edu/~mccune/prover9/>

- [99] J. D. Mitchell and others, Semigroups - GAP package, Version 2.6, (2015).  
<http://www-groups.mcs.st-andrews.ac.uk/~jamesm/semigroups.php>
- [100] J. Berman and S. Burris, A computer study of 3-element groupoids. Logic and algebra (Pontignano, 1994), 379–429, Lecture Notes in Pure and Appl. Math., 180, Dekker, New York, 1996.  
<https://www.math.uwaterloo.ca/~snburris/htdocs/gpd.html>



## Appendix A

### Website Documentation

This section introduces the documentation present in the website <http://sgv.pythonanywhere.com/>.

# Varieties of Semigroups

J.Araújo, J.P.Araújo, P.J.Cameron, E.W.H.Lee, J.Raminhos

Semigroups	Multiplication table	Presentation to Cayley	GAP smallsemi ID
GAP smallgroup ID			
Varieties	Variety by ID	Identities	Varieties filter
Conjectures (/static/ConjecturesOrder6.pdf)		Options	Documentation Credits

## Documentation

Introduction	
<b>Semigroups</b> <ul style="list-style-type: none"> <li>• Multiplication table</li> <li>• Semigroup Variety</li> <li>• Group Variety</li> <li>• Cayley to Presentation</li> <li>• Presentation to Cayley</li> <li>• GAP smallsemi ID</li> <li>• GAP smallgroup ID</li> <li>• Define set of elements</li> <li>• Bands and other special cases</li> </ul>	<b>Varieties</b> <ul style="list-style-type: none"> <li>• Variety by ID</li> <li>• Identities</li> <li>• Varieties Filter</li> <li>• Conjectures</li> </ul>

## Introduction

Given a finite semigroup  $S$  as input (by specifying the multiplication table, presentation, GAP smallsemi or smallgroup ID), this site returns:

- The representative in the isomorphism class of  $S$ , whose vector  $S$  is lexicographically the least;
- A basis for the variety  $\text{var}(S)$ , if  $\text{var}(S) = \text{var}(B)$  for some variety whose identification system is available in the variety database.

The variety database (presently, the identification systems available include all 218 varieties generated by semigroups of order up to five) can also be accessed by using the following options:

- Input of the variety ID;
- Search for a variety whose identity basis is equivalent to a given set of identities;
- Return the list of all varieties in the database, implying or implied by a set of user identities, and draw a lattice of the resulting varieties.

The site will also display a list of known varieties generated by semigroups of order 6, and conjectures for the varieties not known.

## Multiplication table

Enter a multiplication table of a semigroup  $S$ . Default elements are 1 to  $N$ , being  $N$  the *order* of the set, but base 0 instead of 1 or even specific elements can be defined at the option "Define set elements".

Elements can be separated by "," or spaces, and optionally include "[" and "]" to enclose each line and/or the full multiplication table. If the elements are all single-digit, all or part of the separators can be omitted. For instance, all below input strings can be used to input the same multiplication table:

1 1 1 1 1 1 1 1 2	space separated
1,1,1,1,1,1,1,1,2	comma separated
1, 1, 1, 1, 1, 1, 1, 1, 2	mixed commas and spaces
[1, 1, 1, 1, 1, 1, 1, 1, 2]	"[" and "]" enclosed
[[ 1, 1, 1 ], [ 1, 1, 1 ], [ 1, 1, 2 ]]	GAP syntax
111 111 112	separators omitted (only for single digit elements)
111111112	separators omitted (only for single digit elements)

Using the GAP syntax option, it's possible to copy a multiplication table from GAP and paste it here. For example, to get the multiplication table of the group with ID=(5,1) at the SmallGroup GAP package:

```
gap> MultiplicationTable (SmallGroup (5,1));
[[ 1, 2, 3, 4, 5 ], [ 2, 3, 4, 5, 1 ], [ 3, 4, 5, 1, 2 ], [ 4, 5,
1, 2, 3 ], [ 5, 1, 2, 3, 4 ] ]
```

The number of multiplication tables values must be exactly  $order^2$ , otherwise an error will be returned. Only semigroups will be accepted, so the associativity property is checked.

## Semigroup Variety

After entering a multiplication table or selecting a GAP smallsemi ID, by pressing "Semigroup Variety", the site will give a basis for the variety  $var(S)$ , if  $var(S) = var(B)$  for some variety whose identification system is available in the variety database. Semigroups up to order 100 are accepted, but the representative in the isomorphism class of  $S$ , whose vector  $S$  is lexicographically the least, will only be computed in case the order of  $S$  is less or equal to 10.

## Group Variety

## APPENDIX A - WEBSITE DOCUMENTATION

After selecting a GAP smallgroup ID, by pressing "Group Variety", the site will give known information about the group variety generated by the chosen group. Semigroups up to order 255 are accepted.

### Presentation to Cayley

Identify a semigroup by entering its presentation in Prover9 syntax, or choose one of the examples provided.

The presentation is divided in two parts: the theory to follow and one more relations (identities) between initial elements of the set.

Use Prover9 syntax to specify the identities that define the theory and the relations. Finalize each identity with the character ".".

#### Examples:

Consider the following example presentations, and how to enter corresponding theory and relations into the site using Prover9 syntax:

Presentation	Theory	Relations
$\langle a, e \mid ea^2=a^2, e^2=ae=e \rangle = \{ a, e, a^2, ea \}$	$x^*(y*z)=(x*y)*z.$	$(e*a)*a=a*a. e*e=a*e. a*e=e.$
$\langle a \mid a^5 = 1 \rangle = \{ a, a^2, a^3, a^4, 1 \}$	$x^*(y*z)=(x*y)*z. x*1=x. 1*x=x.$	$((a*a)*a)*a=1.$
$\langle a, e \mid ae=0, ea=a, e^2=e \rangle \cup \{1\} = \{ 0, a, e, 1 \}$	$x^*(y*z)=(x*y)*z. x*0=0. 0*x=0. x*1=x. 1*x=x.$	$a*e=0. e*a=a. e*e=e.$

The site will create new elements of the set if necessary to close the multiplication table. If more than 20 elements are reached, an error will be returned.

### Cayley to Presentation

After entering a multiplication table or selecting a GAP smallsemi ID, by pressing "Cayley to Presentation", the site will produce a presentation from the semigroup's multiplication table.

### GAP smallsemi ID

Specify a semigroup by entering the ID defined at GAP package "smallsemi". Orders up to 6 are accepted, with the maximum sequence number corresponding to the number of different semigroups of that order (semigroups considered equivalent if isomorphic or anti-

isomorphic):

Order	Sequence
2	1 - 4
3	1 - 18
4	1 - 126
5	1 - 1160
6	1 - 15973

---

### GAP smallgroup ID

Specify a semigroup by entering the ID defined at GAP package "smallgroups". Orders up to 255 are accepted.

---

### Define set of elements

Define the elements of S to use at "multiplication table" option. The elements specified will also be used on other outputs of the site.

- Default elements are named 1 to N, with N equal to the order of S.
- Another option is start elements with 0 up to N-1.
- Choose "other" to enter other names for elements. Separate elements with commas or spaces. If an insufficient number of elements is provided, the site will use numbers to name the necessary additional elements.

---

### Bands and other special cases

The site deals with special cases like bands, groups and order 6 semigroups that generate non-finitely based varieties. Multiplication tables of some examples are:

- Bands:
  - Band 16: [0000000,0100116,2222222,3333333,0103456,0133456,0100666]
  - Band 17: [0000000,0101156,2222222,0123356,0124456,0101656,0106656]
  - Band 18: [000000,010145,222222,012345,015445,555555]
  - Band 19: [000045,011145,012345,033345,004545,055545]
  - Band 20: [00000000,01011567,22222222,01033567,01044567,01055567,01715567,77777777]

## APPENDIX A - WEBSITE DOCUMENTATION

- Non-finitely based semigroups of order 6:
    - B12: [000000, 000112, 012020, 000335, 012345, 035050]
    - A12: [000000, 000112, 012122, 000335, 012345, 035355]
    - AG2: [000005, 000125, 012125, 000345, 034345, 555550]
    - L: [000000, 000001, 000002, 001031, 002042, 011335]
- 

### Variety by ID

Enter the variety ID (order of primitive generator and sequence number). With the current variety database, accepted sequence numbers are:

Order	Sequence
1	1 - 1
2	1 - 5
3	1 - 14
4	1 - 53
5	1 - 145

---

### Identities

Enter one or more identities in Prover9 format, and the site will retrieve the variety whose identity basis is equivalent to the set of identities entered.

Use Prover9 syntax to specify the identities that define the theory and the relations. Finalize each identity with the character ".".

#### Example 1:

Enter the identities "y=y\*z. x=x\*x." (spaces are optional) and press "Go!". Variety (2,3), whose identity basis is the identity  $xy=x$ , will be displayed, as these sets of identities are equivalent.

#### Example 2:

After accessing a variety, for instance with "Variety ID" option, it's possible to use the "Copy" button to copy the identity basis into the clipboard, in Prover9 format. Try to past these identities into the "Identities" option, and the site will find the corresponding variety.

---

## Varieties Filter

Suppose we have some property and want to check which varieties in the database satisfy it. This can be done on the website, using these two distinct functionalities:

- Returns the varieties whose identity basis is implied by the user's assumptions. To use it fill assumptions and press "Prover9" on the left side of the screen to search for proofs, or "Mace4" to search for countermodels.
- Returns the varieties whose identity basis implies the user's goals. To use it fill goals and press "Prover9" on the right of the screen to search for proofs, or "Mace4" to search for countermodels.

Use Prover9 syntax to specify the identities defining assumptions and/or goals. Finalize each identity with the character ".".

It's not necessary to specify the associativity property, it will be included by default.

Prover9, an automatic theorem prover, and its accompanying program, Mace 4, which look for countermodels, will run simultaneously to check the requested implications.

If the filtered set of varieties has less of 80 varieties, it's possible to obtain a lattice of those varieties by pressing "Lattice". The lattice graphic can be removed, getting back to the list, by pressing "List".

### Example:

Get only the varieties from the database whose semigroups are bands. These semigroups satisfy the identity  $x^2 \approx x$ .

Fill the "Goals:" input field with the following string: " $x*x=x$ .", and click "Prover9" in the right option "Varieties whose identity basis implies the user's goals:"

You should get the 15 varieties below:

Variety	Identity basis (apart from $xx \approx x$ )	Semigroups in this variety
(1,1)	$x \approx y$	The trivial semigroup
(2,2)	$xy \approx yx$	Semilattices
(2,3)	$xy \approx x$	Left-zero semigroups
(2,4)	$xy \approx y$	Right-zero semigroups
(3,7)	$xyz \approx xzy$	Left normal bands
(3,8)	$xyz \approx yxz$	Right normal bands
(3,10)	$xyx \approx xy$	Semilattices of left-zero semigroups
(3,13)	$xyx \approx yx$	Semilattices of right-zero semigroups

## APPENDIX A - WEBSITE DOCUMENTATION

<b>(4,32)</b>	$xyzx \approx xzyx$	Normal bands
<b>(4,34)</b>	$xyxz \approx xyz$	Left quasi-normal bands
<b>(4,44)</b>	$xyzy \approx xzy$	Right quasi-normal bands
<b>(4,48)</b>	$xyx \approx x$	Rectangular bands
<b>(5,101)</b>	$xyxzx \approx xyzx$	Regular bands
<b>(5,102)</b>	$xyzxz \approx xyz$	Left semi-normal bands
<b>(5,142)</b>	$xyz \approx xzxyz$	Right semi-normal bands

Press "Lattice" to get the lattice of these varieties.

Add " $x*y=y*x.$ " to the "Goals" field to get " $x*x=x. x*y=y*x.$ ". Press "Prover9" in the right side of the screen. This time only varieties whose semigroups are commutative bands will be obtained (only 3 varieties in the current database).